

PROJECT: 44856.3.39 TIP: W-5710AK

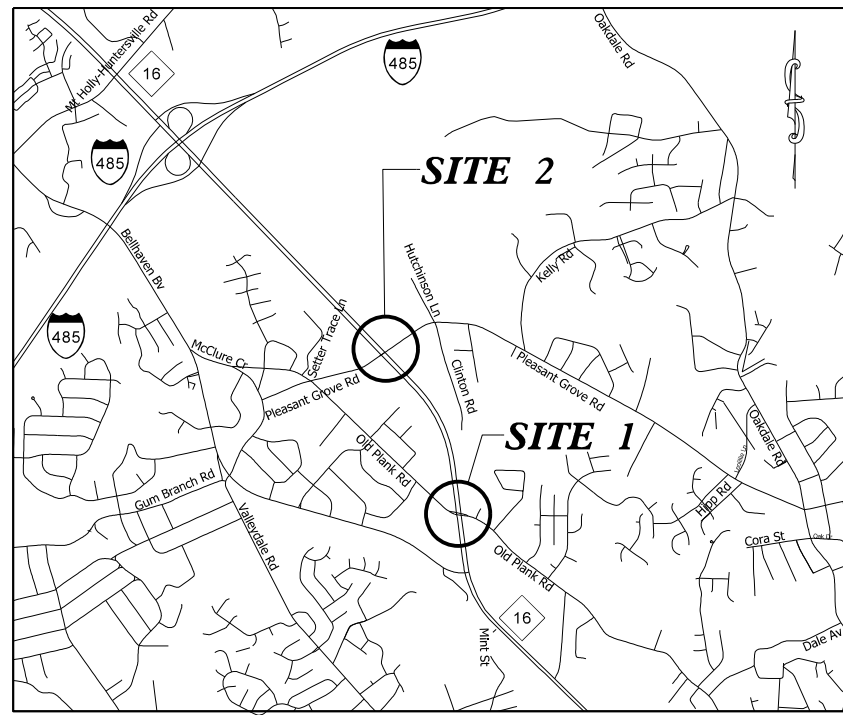

VICINITY MAP NOT TO SCALE

STATE OF NORTH CAROLINA
DIVISION OF HIGHWAYS
MECKLENBURG COUNTY

LOCATION: INTERSECTIONS ON NC 16 AT OLD PLANK RD.(SR-2006)
AND PLEASANT GROVE RD.(SR-2008)

TYPE OF WORK: GRADING, PAVING, MILLING, DRAINAGE, GUARDRAIL, MONOLITHIC
CONCRETE ISLANDS, THERMOPLASTIC PAVEMENT MARKINGS, AND SIGNALS

STATE	STATE PROJECT REFERENCE NO.	SHEET NO.	TOTAL SHEETS
N.C.	44856.3.39	1	
STATE PROJ. NO.	F.A. PROJ. NO.	DESCRIPTION	
44856.1.39	HSIP-0016(065)	P.E.	
44856.2.39	HSIP-0016(065)	R/W	
44856.3.39	HSIP-0016(065)	CONST.	

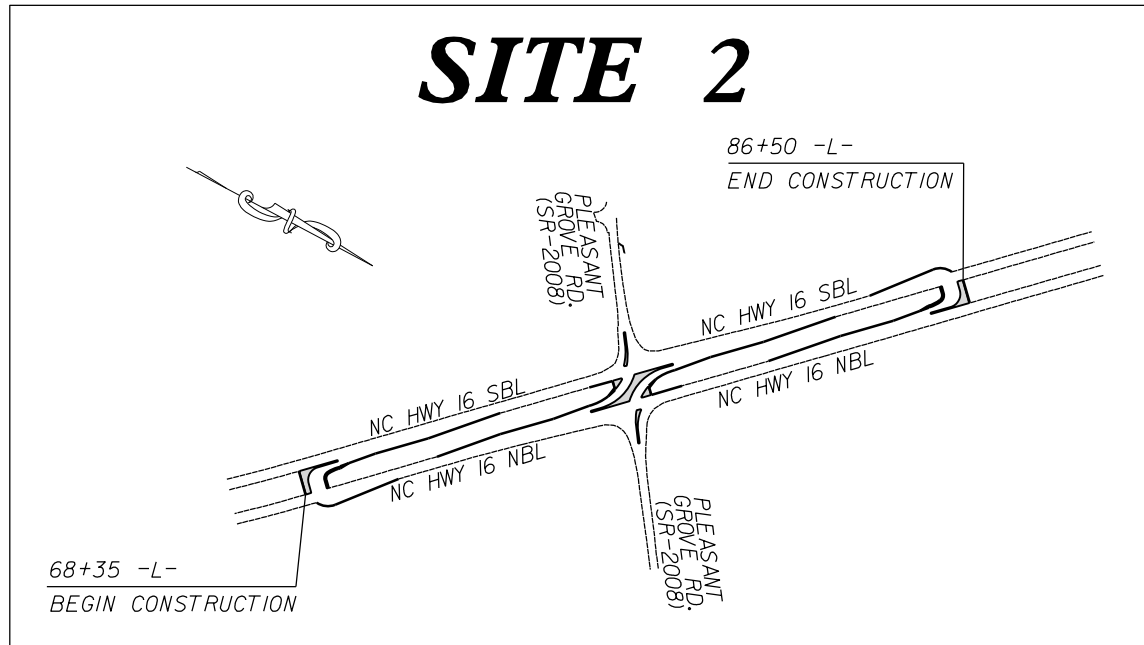
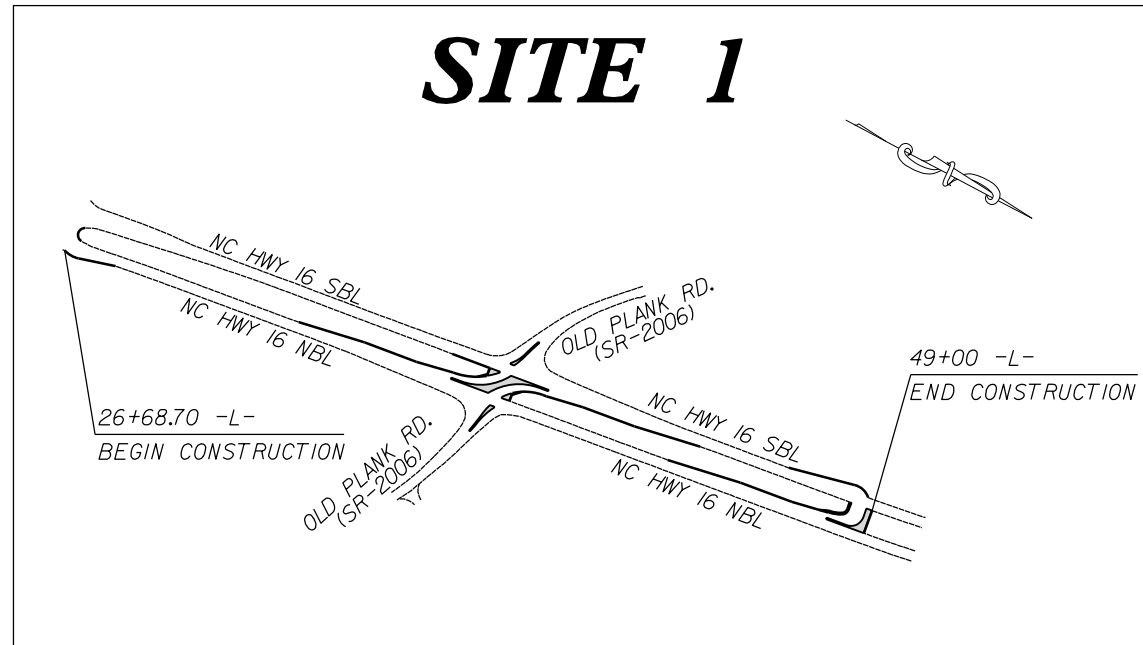

CLEARING ON THIS PROJECT SHALL BE TO THE LIMITS ESTABLISHED BY METHOD III AS DESCRIBED IN THE NCDOT STANDARD DRAWINGS

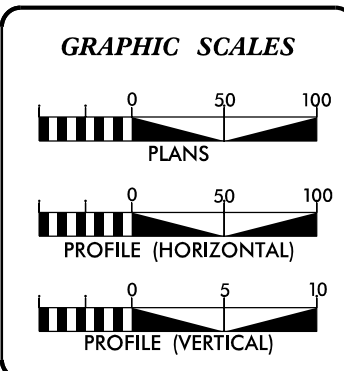

DESIGN DATA

ADT	=	
ADT	=	
DHV	=	%
D	=	%
T	=	%
V	=	MPH

PROJECT LENGTH

LENGTH OF ROADWAY PROJECT	44856.3.39	=	0.77	MILES
TOTAL LENGTH OF STATE PROJECT	44856.3.39	=	0.77	MILES

Prepared In the Office of:
DIVISION OF HIGHWAYS
DIVISION TEN
DIVISION DESIGN / CONSTRUCT UNIT

2018 STANDARD SPECIFICATIONS

RIGHT OF WAY DATE: N/A	DONALD HARWARD PROJECT ENGINEER
LETTING DATE: JULY 20, 2022	TRAVIS LOWDER PROJECT DESIGN ENGINEER

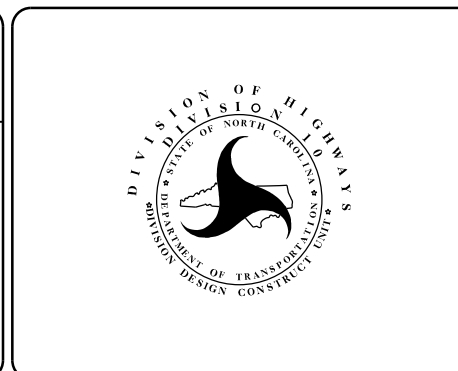

ROADWAY DESIGN ENGINEER

DocuSigned by:
Michael E. Brown
A92E75CC0FFB43B...

SIGNATURE

SURVEY CONTROL SHEET

DATUM DESCRIPTION

THE LOCALIZED COORDINATE SYSTEM DEVELOPED FOR THIS PROJECT IS BASED ON THE STATE PLANE COORDINATES ESTABLISHED BY NCDOT FOR MONUMENT "GPS-5"

WITH NAD 83/NA 2011 STATE PLANE GRID COORDINATES OF
 NORTHING: 571690.724(fft) EASTING: 1426698.488(fft)
 ELEVATION: 717.264(fft)

THE AVERAGE COMBINED GRID FACTOR USED ON THIS PROJECT (GROUND TO GRID) IS: 0.99984381

THE N.C. LAMBERT GRID BEARING AND LOCALIZED HORIZONTAL GROUND DISTANCE FROM "GPS-5" TO "L" STATION 10+00 IS
 S 17° 55' 41" E 4564.98'

ALL LINEAR DIMENSIONS ARE LOCALIZED HORIZONTAL DISTANCES
 VERTICAL DATUM USED IS NAVD 88

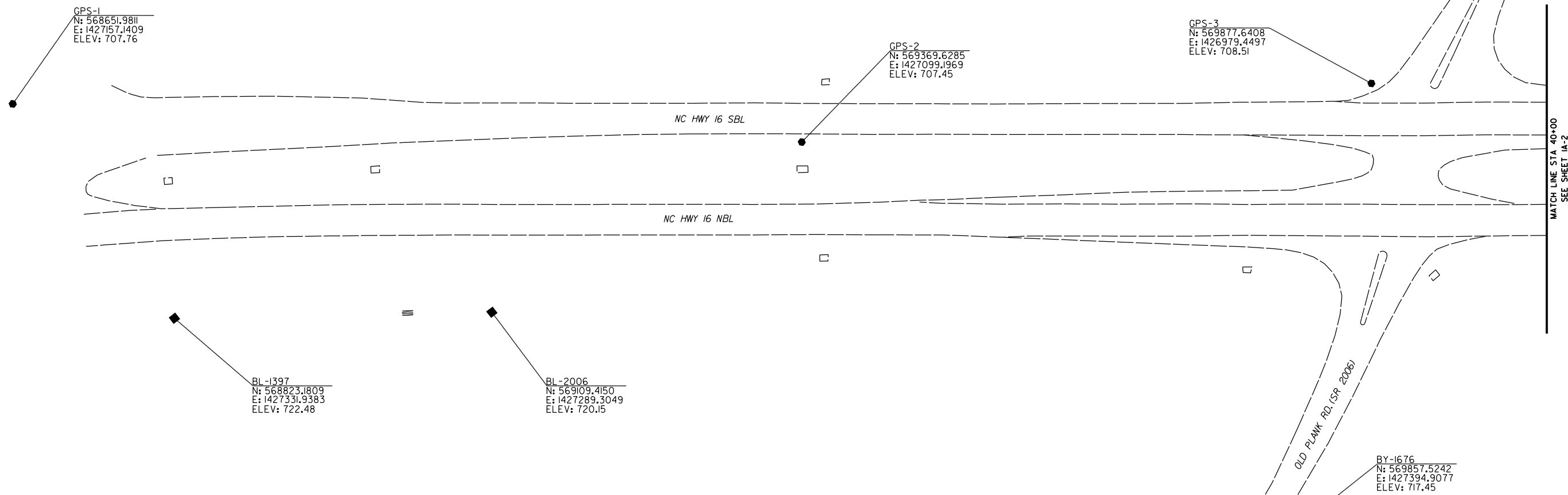
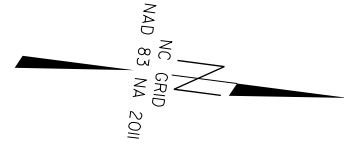

MATCH LINE STA 40+00
SEE SHEET IA-2

BL	POINT	DESC.	NORTH	EAST	ELEVATION	L STATION	OFFSET
	1		568651.9811	1427157.1409	707.76	26+10.41	77.81 LT
	1397		568823.1809	1427331.9383	722.48	27+40.92	130.17 RT
	2006		569109.4150	1427289.3049	720.15	30+38.48	130.50 RT
	2		569369.6285	1427099.1969	707.45	33+20.97	24.59 LT
	3		569877.6408	1426979.4497	708.51	38+40.16	78.06 LT
	4		570842.5548	1426908.6232	713.28	48+06.18	24.29 LT
	1495		570862.6188	1426805.6218	707.33	48+39.54	123.82 LT
	5		571690.7240	1426698.4876	717.26	56+89.32	23.87 LT
	6		572377.8727	1426293.1135	727.99	64+96.41	23.19 LT
	394		572478.8080	1426327.0875	730.64	65+52.69	66.95 RT
	513		572678.6792	1426193.0864	723.30	67+85.84	100.52 RT
	395		572653.3519	1426170.2967	734.67	67+83.14	66.56 RT
	7		572993.4253	1425713.6788	741.10	73+44.24	26.59 LT
	8		573269.3295	1425350.1856	739.30	77+95.15	96.82 LT
	82		573723.3311	1425146.4420	731.85	82+63.42	71.57 RT
	9		573941.9811	1424801.9202	721.32	86+59.94	24.73 LT

BY	POINT	DESC.	NORTH	EAST	ELEVATION	Y STATION	OFFSET
	3		569877.6408	1426979.4497	708.51	13+95.97	57.99 RT
	1676		569857.5242	1427394.9077	717.45	18+01.87	23.34 LT

NOTES:

- PROJECT CONTROL WAS ESTABLISHED USING GNSS, THE GLOBAL NAVIGATION SATELLITE SYSTEM.
- THE SURVEY CONTROL DATA FOR THIS PROJECT HAS BEEN COMPILED BY THE DIVISION IO DDC UNIT. IF FURTHER INFORMATION REGARDING PROJECT CONTROL IS NEEDED, PLEASE CONTACT THE DIVISION IO DDC UNIT.

SIGNALIZED RCI ON NC 16
AT OLD PLANK RD.(SR-2006) AND
PLEASANT GROVE RD.(SR-2008)

SCALE	1"=50'		REVISIONS
DATE	3-2022		
DWG. BY	TBL		
DESIGN BY	TBL		
APPROVED	JDH		

SURVEY CONTROL SHEET

DATUM DESCRIPTION

THE LOCALIZED COORDINATE SYSTEM DEVELOPED FOR THIS PROJECT IS BASED ON THE STATE PLANE COORDINATES ESTABLISHED BY NCDOT FOR MONUMENT "GPS-5" WITH NAD 83/NA 2011 STATE PLANE GRID COORDINATES OF NORTHING: 571690.724(ft) EASTING: 1426698.488(ft) ELEVATION: 717.264(ft)

THE AVERAGE COMBINED GRID FACTOR USED ON THIS PROJECT (GROUND TO GRID) IS: 0.99984381

THE N.C. LAMBERT GRID BEARING AND LOCALIZED HORIZONTAL GROUND DISTANCE FROM "GPS-5" TO "L" STATION 10+00 IS
 S 17° 55' 41" E 4564.98'

ALL LINEAR DIMENSIONS ARE LOCALIZED HORIZONTAL DISTANCES
 VERTICAL DATUM USED IS NAVD 88

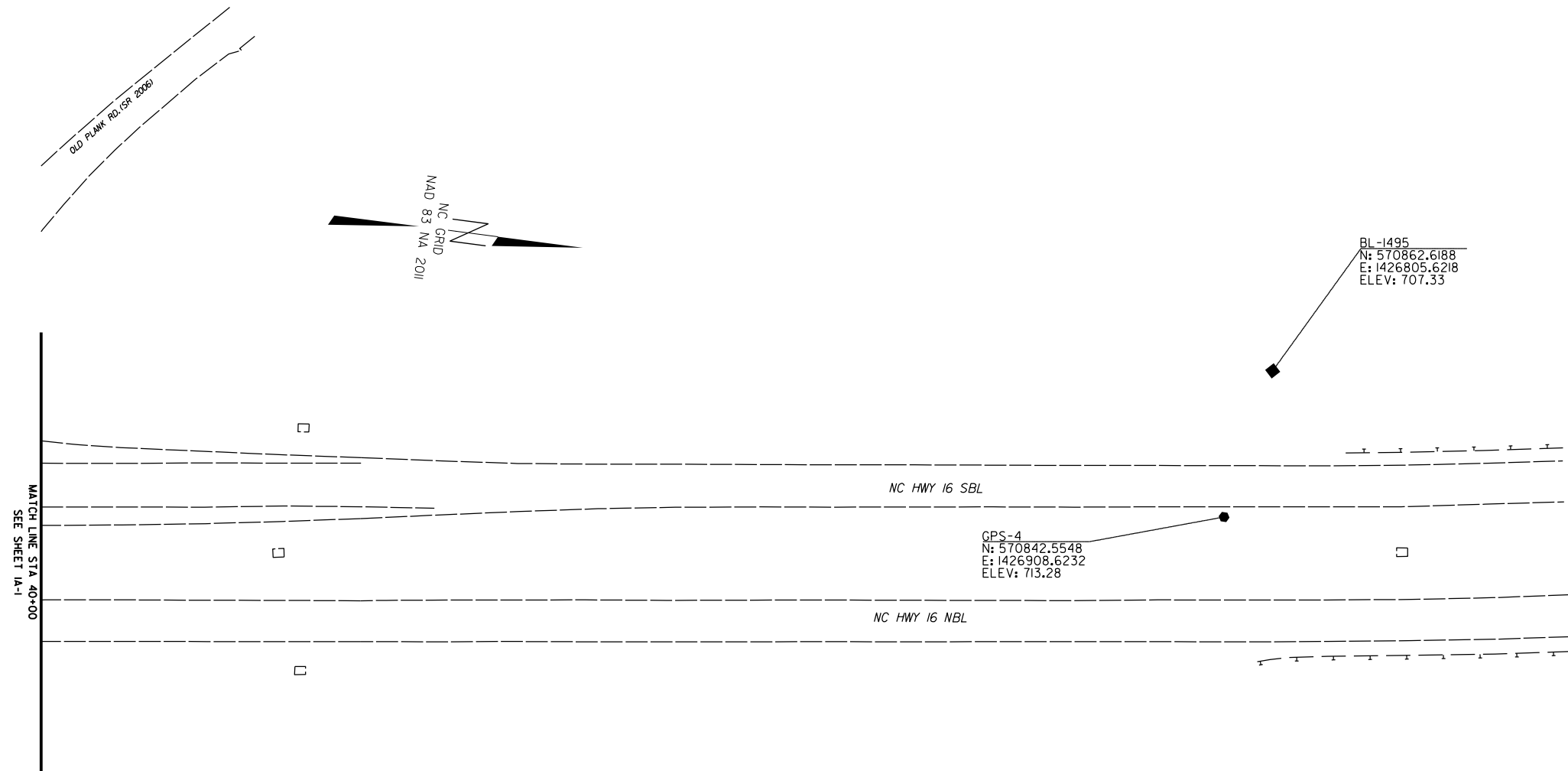

BL	POINT	DESC.	NORTH	EAST	ELEVATION	L. STATION	OFFSET
	1		568651.9811	1427157.1409	707.76	26+10.41	77.81 LT
	1397		568823.1809	1427331.9383	722.48	27+40.92	130.17 RT
	2006		569109.4150	1427289.3049	720.15	30+38.48	130.50 RT
	2		569369.6285	1427099.1969	707.45	33+20.97	24.59 LT
	3		569877.6408	1426979.4497	708.51	38+40.16	78.06 LT
	4		570842.5548	1426908.6232	713.28	48+06.18	24.29 LT
	1495		570862.6188	1426805.6218	707.33	48+39.54	123.82 LT
	5		571690.7240	1426698.4876	717.26	56+89.32	23.87 LT
	6		572377.8727	1426293.1135	727.99	64+96.41	23.19 LT
	394		572478.8080	1426327.0875	730.64	65+52.69	66.95 RT
	513		572678.6792	1426193.0864	723.30	67+85.84	100.52 RT
	395		572653.3519	1426170.2967	734.67	67+83.14	66.56 RT
	7		572993.4253	1425713.6788	741.10	73+44.24	26.59 LT
	8		573269.3295	1425350.1856	739.30	77+95.15	96.82 LT
	82		573723.3311	1425146.4420	731.85	82+63.42	71.57 RT
	9		573941.9811	1424801.9202	721.32	86+59.94	24.73 LT

BY	POINT	DESC.	NORTH	EAST	ELEVATION	Y STATION	OFFSET
	3		569877.6408	1426979.4497	708.51	13+95.97	57.99 RT
	1676		569857.5242	1427394.9077	717.45	18+01.87	23.34 LT

NOTES:

- PROJECT CONTROL WAS ESTABLISHED USING GNSS, THE GLOBAL NAVIGATION SATELLITE SYSTEM.
- THE SURVEY CONTROL DATA FOR THIS PROJECT HAS BEEN COMPILED BY THE DIVISION IO DDC UNIT. IF FURTHER INFORMATION REGARDING PROJECT CONTROL IS NEEDED, PLEASE CONTACT THE DIVISION IO DDC UNIT.

SIGNALIZED RCI ON NC 16
 AT OLD PLANK RD.(SR-2006) AND
 PLEASANT GROVE RD.(SR-2008)

SCALE	1"=50'		REVISIONS
DATE	3-2022		
DWG. BY	TBL		
DESIGN BY	TBL		
APPROVED	JDH		

SURVEY CONTROL SHEET

PROJECT NO.	SHEET NO.
44856.3.39	IA-3
F.A. PROJECT NO. HSP-00610651	

BL	POINT	DESC.	NORTH	EAST	ELEVATION	L STATION	OFFSET	BY	POINT	DESC.	NORTH	EAST	ELEVATION	Y STATION	OFFSET
	1		568651.9811	1427157.1409	707.76	26+10.41	77.81 LT		3		569877.6408	1426979.4497	708.51	13+95.97	57.99 RT
	1397		568823.1809	1427331.9383	722.48	27+40.92	130.17 RT		1676		569857.5242	1427394.9077	717.45	18+01.87	23.34 LT
	2006		569109.4150	1427289.3049	720.15	30+38.48	130.50 RT								
	2		569369.6285	1427099.1969	707.45	33+20.97	24.59 LT								
	3		569877.6408	1426979.4497	708.51	38+40.16	78.06 LT								
	4		570842.5548	1426908.6232	713.28	48+06.18	24.29 LT								
	1495		570862.6188	1426805.6218	707.33	48+39.54	123.82 LT								
	5		571690.7240	1426698.4876	717.26	56+89.32	23.87 LT								
	6		572377.8727	1426293.1135	727.99	64+96.41	23.19 LT								
	394		572478.8080	1426327.0875	730.64	65+52.69	66.95 RT								
	513		572678.6792	1426193.0864	723.30	67+85.84	100.52 RT								
	395		572653.3519	1426170.2967	734.67	67+83.14	66.56 RT								
	7		572993.4253	1425713.6788	741.10	73+44.24	26.59 LT								
	8		573269.3295	1425350.1856	739.30	77+95.15	96.82 LT								
	82		573723.3311	1425146.4420	731.85	82+63.42	71.57 RT								
	9		573941.9811	1424801.9202	721.32	86+59.94	24.73 LT								

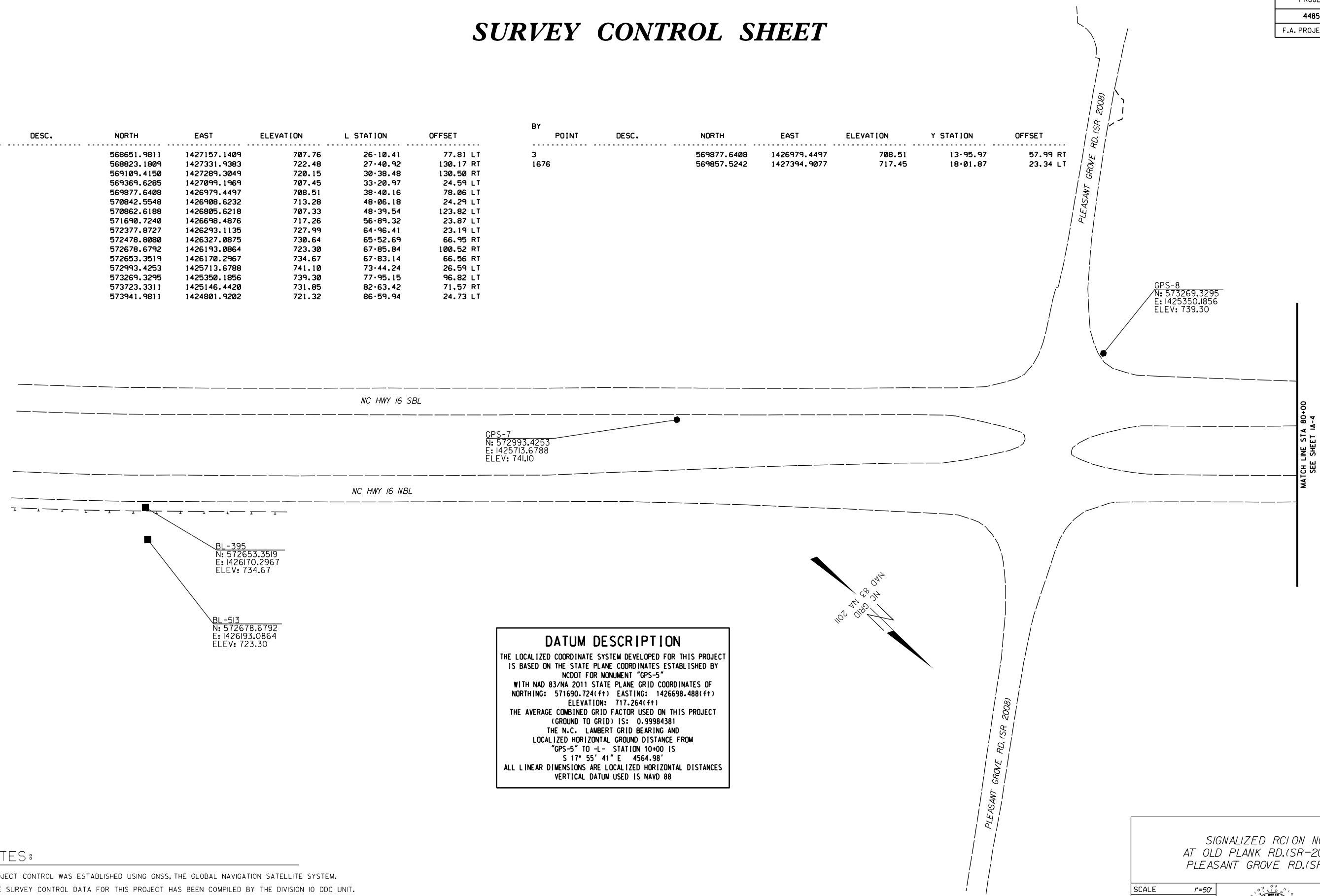

DATUM DESCRIPTION

THE LOCALIZED COORDINATE SYSTEM DEVELOPED FOR THIS PROJECT IS BASED ON THE STATE PLANE COORDINATES ESTABLISHED BY NCDOT FOR MONUMENT "GPS-5"

WITH NAD 83/NA 2011 STATE PLANE GRID COORDINATES OF
 NORTHING: 571690.724(±ft) EASTING: 1426698.488(±ft)
 ELEVATION: 717.264(±ft)

THE AVERAGE COMBINED GRID FACTOR USED ON THIS PROJECT (GROUND TO GRID) IS: 0.99984381

THE N.C. LAMBERT GRID BEARING AND LOCALIZED HORIZONTAL GROUND DISTANCE FROM "GPS-5" TO "L" STATION 10+00 IS
 S 17° 55' 41" E 4564.98'

ALL LINEAR DIMENSIONS ARE LOCALIZED HORIZONTAL DISTANCES
 VERTICAL DATUM USED IS NAVD 88

NOTES:

1. PROJECT CONTROL WAS ESTABLISHED USING GNSS, THE GLOBAL NAVIGATION SATELLITE SYSTEM.
2. THE SURVEY CONTROL DATA FOR THIS PROJECT HAS BEEN COMPILED BY THE DIVISION 10 DDC UNIT. IF FURTHER INFORMATION REGARDING PROJECT CONTROL IS NEEDED, PLEASE CONTACT THE DIVISION 10 DDC UNIT.

SIGNALIZED R/CION NC 16
 AT OLD PLANK RD.(SR-2006) AND
 PLEASANT GROVE RD.(SR-2008)

SCALE	1"=50'		REVISIONS
DATE	3-2022		
DWG. BY	TBL		
DESIGN BY	TBL		
APPROVED	JDH		

SURVEY CONTROL SHEET

DATUM DESCRIPTION

THE LOCALIZED COORDINATE SYSTEM DEVELOPED FOR THIS PROJECT IS BASED ON THE STATE PLANE COORDINATES ESTABLISHED BY NCDOT FOR MONUMENT "GPS-5" WITH NAD 83/NA 2011 STATE PLANE GRID COORDINATES OF NORTHING: 571690.724(ft) EASTING: 1426698.488(ft) ELEVATION: 717.264(ft)

THE AVERAGE COMBINED GRID FACTOR USED ON THIS PROJECT (GROUND TO GRID) IS: 0.99984381

THE N.C. LAMBERT GRID BEARING AND LOCALIZED HORIZONTAL GROUND DISTANCE FROM "GPS-5" TO -L- STATION 10+00 IS
S 17° 55' 41" E 4564.98'

ALL LINEAR DIMENSIONS ARE LOCALIZED HORIZONTAL DISTANCES
VERTICAL DATUM USED IS NAVD 88

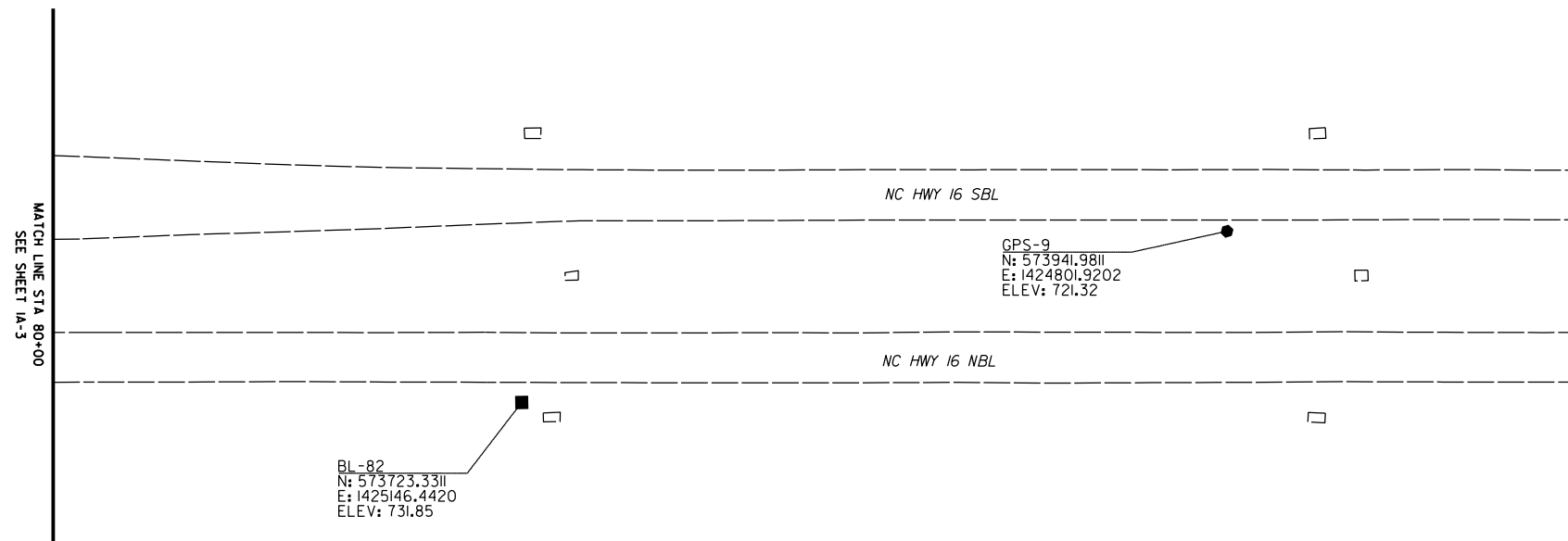
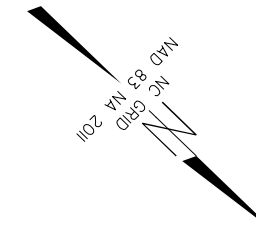

BL POINT	DESC.	NORTH	EAST	ELEVATION
1		568651.9811	1427157.1409	707.76
1397		568823.1809	1427331.9383	722.48
2006		569109.4150	1427289.3049	720.15
2		569369.6285	1427099.1969	707.45
3		569877.6408	1426979.4497	708.51
4		570842.5548	1426908.6232	713.28
1495		570862.6188	1426805.6218	707.33
5		571690.7240	1426698.4876	717.26
6		572377.8727	1426293.1135	727.99
394		572478.8080	1426327.0875	730.64
513		572678.6792	1426193.0864	723.30
395		572653.3519	1426170.2967	734.67
7		572993.4253	1425713.6788	741.10
8		573269.3295	1425350.1856	739.30
82		573723.3311	1425146.4420	731.85
9		573941.9811	1424801.9202	721.32

BY POINT	DESC.	NORTH	EAST	ELEVATION
3		569877.6408	1426979.4497	708.51
1676		569857.5242	1427394.9077	717.45

NOTES:

1. PROJECT CONTROL WAS ESTABLISHED USING GNSS, THE GLOBAL NAVIGATION SATELLITE SYSTEM.
2. THE SURVEY CONTROL DATA FOR THIS PROJECT HAS BEEN COMPILED BY THE DIVISION IO DDC UNIT. IF FURTHER INFORMATION REGARDING PROJECT CONTROL IS NEEDED, PLEASE CONTACT THE DIVISION IO DDC UNIT.

SIGNALIZED R/C ON NC 16
AT OLD PLANK RD.(SR-2006) AND
PLEASANT GROVE RD.(SR-2008)

SCALE	1"=50'		REVISIONS
DATE	3-2022		
DWG. BY	TBL		
DESIGN BY	TBL		
APPROVED	JDH		

PROJECT NO.	SHEET NO.
44856.3.39	1B
F.A. PROJECT NO. HSIP-00610651	

PROPOSED ALIGNMENT SHEET

L

TYPE	STATION	NORTH	EAST
POT	10+00.00	567347.4012	1428103.7009
TS	12+00.04	567487.0590	1427960.4749
SC	15+00.04	567701.0935	1427750.3441
CS	27+33.60	568791.2608	1427205.5416
ST	30+33.60	569087.8048	1427160.5149
TS	47+82.74	570822.4434	1426935.7238
SC	50+82.74	571119.2013	1426891.9883
CS	66+10.92	572480.3285	1426237.9245
ST	69+10.92	572699.8946	1426033.5503
POT	93+28.61	574440.5711	1424355.6680

Y

TYPE	STATION	NORTH	EAST
POT	10+00.00	570136.1083	1426659.5226
PC	10+44.60	570104.4411	1426690.9287
PRC	14+93.87	569918.3478	1427089.6419
PT	19+26.90	569776.7016	1427494.9332

Y1

TYPE	STATION	NORTH	EAST
PC	10+00.00	573024.4948	1425065.7391
PT	12+09.34	573139.3031	1425240.7522
POT	19+57.77	573568.0945	1425854.1744

NOTES:

1. PROJECT CONTROL WAS ESTABLISHED USING GNSS, THE GLOBAL NAVIGATION SATELLITE SYSTEM.
2. THE SURVEY CONTROL DATA FOR THIS PROJECT HAS BEEN COMPILED BY THE DIVISION IO DDC UNIT.
IF FURTHER INFORMATION REGARDING PROJECT CONTROL IS NEEDED, PLEASE CONTACT THE DIVISION IO DDC UNIT.

SIGNALIZED RCI ON NC 16
AT OLD PLANK RD.(SR-2006) AND
PLEASANT GROVE RD.(SR-2008)

SCALE	1"=50'		REVISIONS
DATE	3-2022		
DWG. BY	TBL		
DESIGN BY	TBL		
APPROVED	JDH		

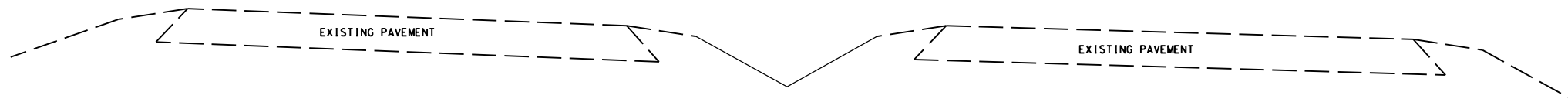
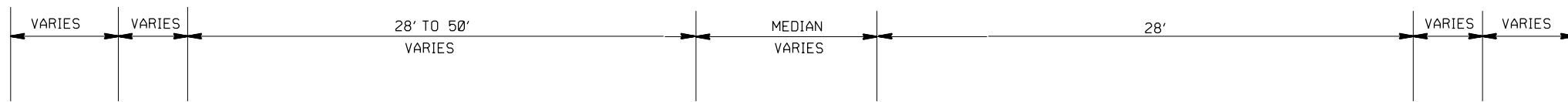
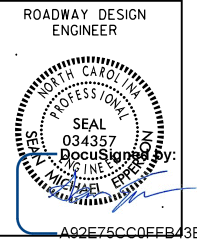

TYPICAL SECTION NO.3
STA 28+12.00 TO 33+16.04 -L-

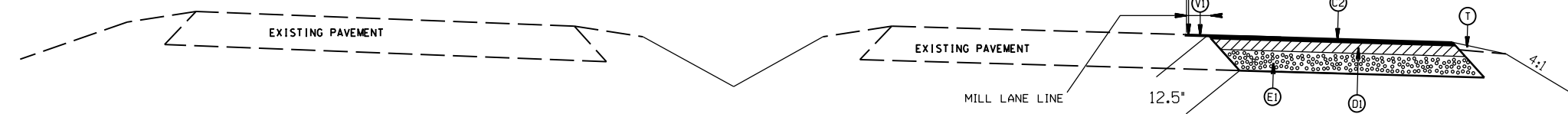
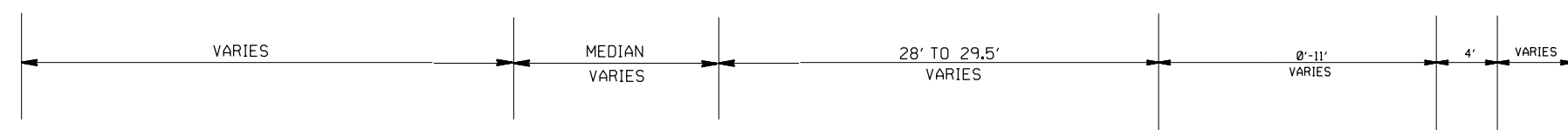

TYPICAL SECTION NO.2
STA 27+05.00 TO 28+12.00 -L-

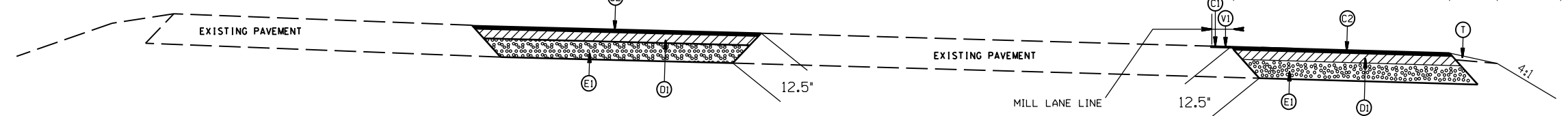

TYPICAL SECTION NO.1
STA 26+68.70 TO 27+05.00 -L-

PAVEMENT SCHEDULE

(C1)	PROP. APPROX. 1½" ASPHALT CONC. SURFACE COURSE, TYPE S9.5B, AT AN AVERAGE RATE OF 168 LBS. PER SQ. YD.
(C2)	PROP. APPROX. 3" ASPHALT CONC. SURFACE COURSE, TYPE S9.5B, AT AN AVERAGE RATE OF 168 LBS. PER SQ. YD., IN TWO EQUAL LAYERS
(D1)	PROP. APPROX. 4" ASPHALT CONC. BINDER COURSE, TYPE I19.0C, AT AN AVERAGE RATE OF 456 LBS. PER SQ. YD.
(E1)	PROP. APPROX. 5.5" ASPHALT CONC. BASE COURSE, TYPE B25.0C, AT AN AVERAGE RATE OF 627 LBS. PER SQ. YD.
(R1)	PROP. 5" MONOLITHIC ISLAND (SURFACE MOUNTED)
(T)	EARTH MATERIAL
(V1)	MILLING ASPHALT PAVEMENT, 1.5" IN DEPTH

SIGNALIZED RCI ON NC 16
AT OLD PLANK RD.(SR-2006) AND
PLEASANT GROVE RD.(SR-2008)

SCALE	N/A
DATE	3-2022
DWG. BY	TBL
DESIGN BY	JCB
APPROVED	JDH



REVISIONS	

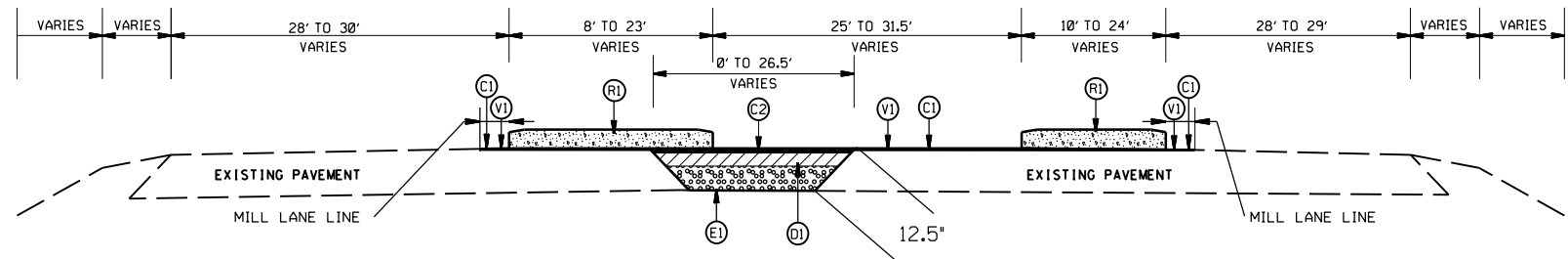
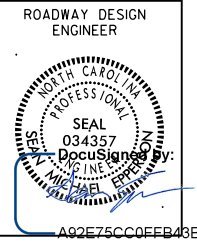

TYPICAL SECTION NO.6
 STA 38+28.00 TO 38+42.19 -L-
 STA 39+01.06 TO 39+07.00 -L-
 STA 76+92.00 TO 77+12.36 -L-
 STA 77+61.18 TO 77+80.00 -L-

PAVEMENT SCHEDULE

(C1)	PROP. APPROX. 1½" ASPHALT CONC. SURFACE COURSE, TYPE S9.5B, AT AN AVERAGE RATE OF 168 LBS. PER SQ. YD.
(C2)	PROP. APPROX. 3" ASPHALT CONC. SURFACE COURSE, TYPE S9.5B, AT AN AVERAGE RATE OF 168 LBS. PER SQ. YD., IN TWO EQUAL LAYERS
(D1)	PROP. APPROX. 4" ASPHALT CONC. BINDER COURSE, TYPE I19.0C, AT AN AVERAGE RATE OF 456 LBS. PER SQ. YD.
(E1)	PROP. APPROX. 5.5" ASPHALT CONC. BASE COURSE, TYPE B25.0C, AT AN AVERAGE RATE OF 627 LBS. PER SQ. YD.
(R1)	PROP. 5" MONOLITHIC ISLAND (SURFACE MOUNTED)
(T)	EARTH MATERIAL
(V1)	MILLING ASPHALT PAVEMENT, 1.5" IN DEPTH

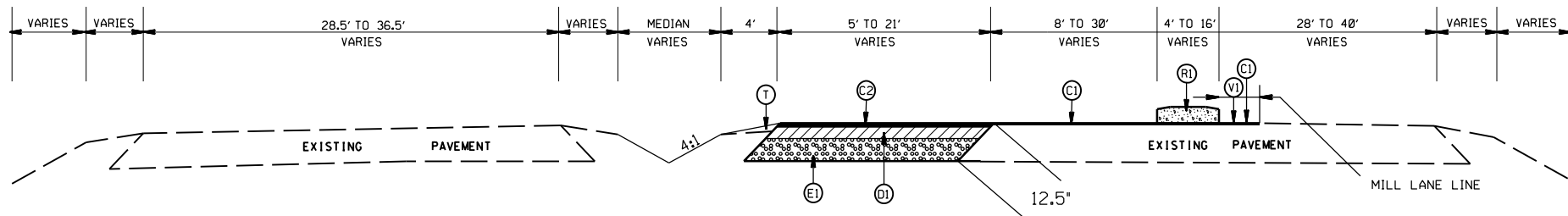

TYPICAL SECTION NO.5
 STA 37+42.00 TO 38+28.00 -L-
 STA 76+15.00 TO 76+92.00 -L-

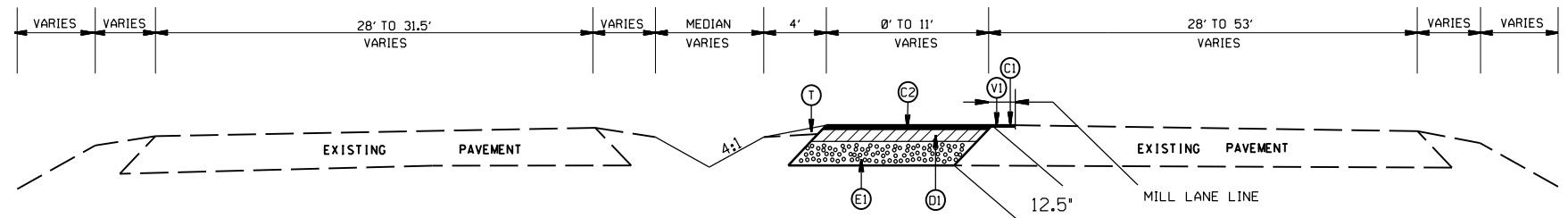

TYPICAL SECTION NO.4
 STA 33+16.04 TO 37+42.00 -L-
 STA 44+17.38 TO 46+54.75 -L-
 STA 73+85.00 TO 76+15.00 -L-
 STA 83+02.00 TO 84+03.03 -L-

SIGNALIZED RCI ON NC 16
 AT OLD PLANK RD.(SR-2006) AND
 PLEASANT GROVE RD.(SR-2008)

SCALE	N/A		REVISIONS
DATE	3-2022		
DWG. BY	TBL		
DESIGN BY	JCB		
APPROVED	JDH		

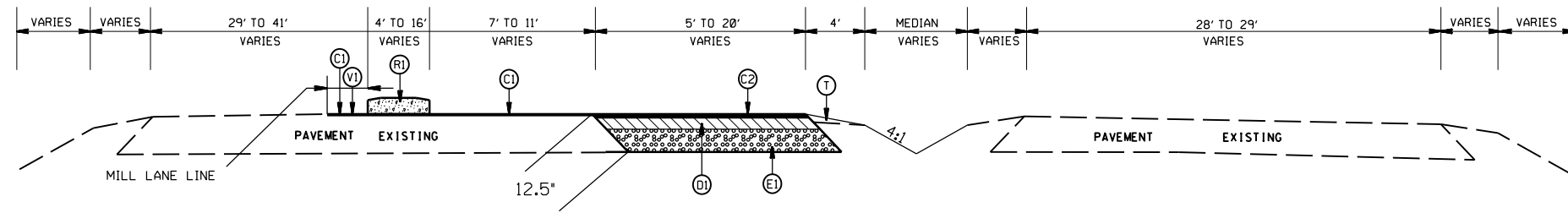

TYPICAL SECTION NO.9
 STA 39+07.00 TO 39+93.00 -L-
 STA 77+80.00 TO 78+57.00 -L-

PAVEMENT SCHEDULE

(C1)	PROP. APPROX. 1½" ASPHALT CONC. SURFACE COURSE, TYPE S9.5B, AT AN AVERAGE RATE OF 168 LBS. PER SQ. YD.
(C2)	PROP. APPROX. 3" ASPHALT CONC. SURFACE COURSE, TYPE S9.5B, AT AN AVERAGE RATE OF 168 LBS. PER SQ. YD., IN TWO EQUAL LAYERS
(D1)	PROP. APPROX. 4" ASPHALT CONC. BINDER COURSE, TYPE I19.0C, AT AN AVERAGE RATE OF 456 LBS. PER SQ. YD.
(E1)	PROP. APPROX. 5.5" ASPHALT CONC. BASE COURSE, TYPE B25.0C, AT AN AVERAGE RATE OF 627 LBS. PER SQ. YD.
(R1)	PROP. 5" MONOLITHIC ISLAND (SURFACE MOUNTED)
(T)	EARTH MATERIAL
(V1)	MILLING ASPHALT PAVEMENT, 1.5" IN DEPTH

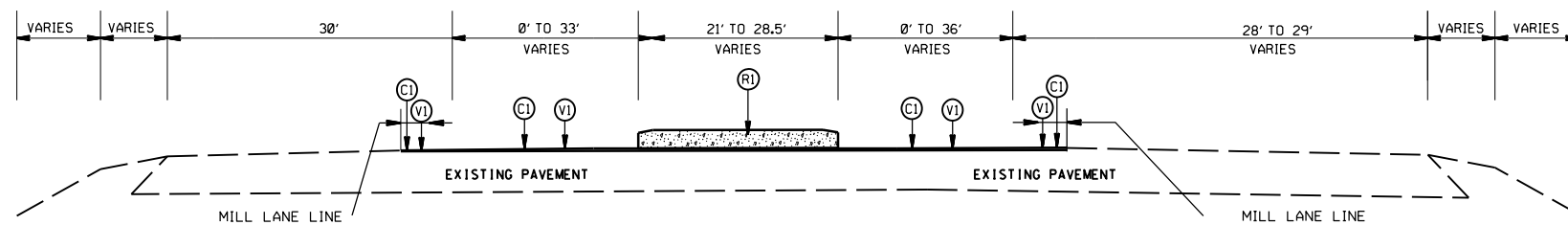

TYPICAL SECTION NO.8
 STA 38+56.46 TO 38+84.68 -L-
 STA 77+17.56 TO 77+53.23 -L-

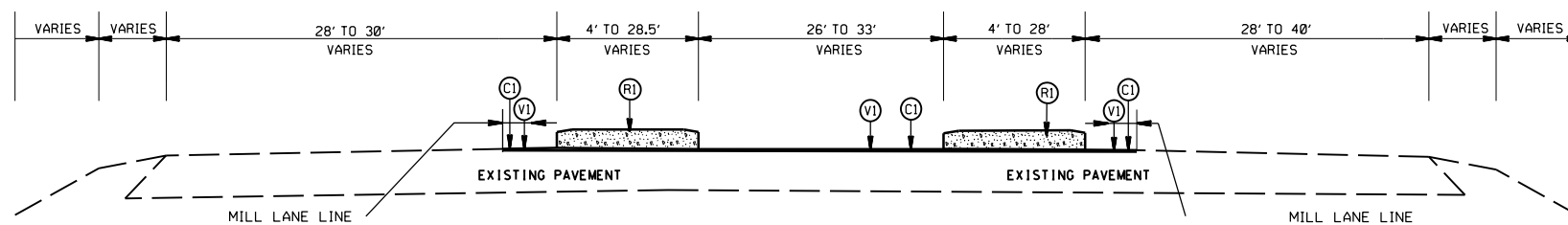

TYPICAL SECTION NO.7
 STA 38+42.19 TO 38+56.46 -L-
 STA 38+84.68 TO 39+01.06 -L-
 STA 77+12.36 TO 77+17.56 -L-
 STA 77+53.23 TO 77+61.18 -L-

SIGNALIZED RCI ON NC 16
 AT OLD PLANK RD.(SR-2006) AND
 PLEASANT GROVE RD.(SR-2008)

SCALE	N/A		REVISIONS
DATE	3-2022		
DWG. BY	TBL		
DESIGN BY	JCB		
APPROVED	JDH		

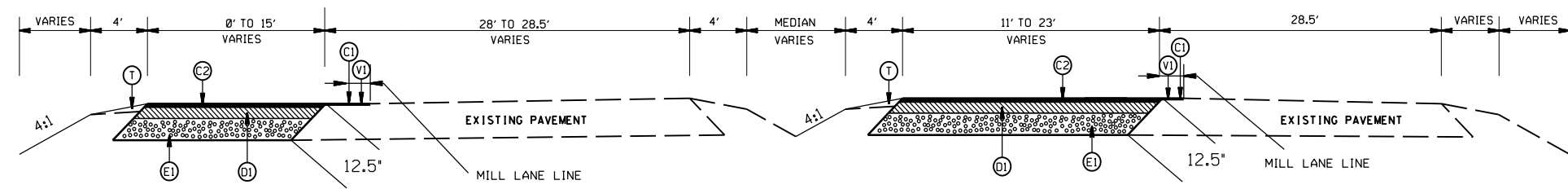
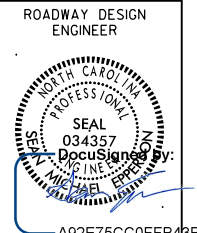

TYPICAL SECTION NO.12
 STA 46+54.75 TO 47+94.00 -L-
 STA 84+03.03 TO 85+44.00 -L-

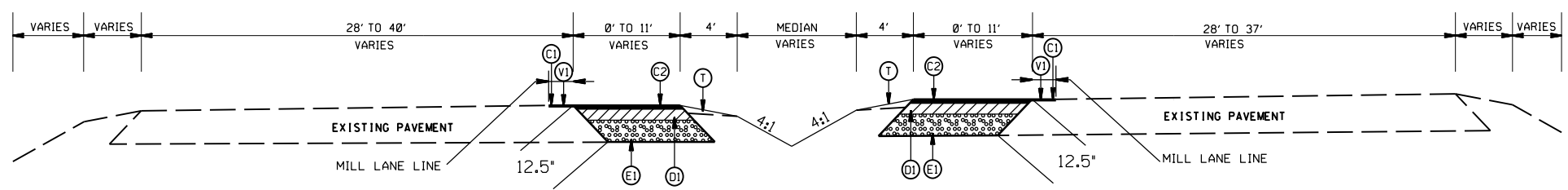

TYPICAL SECTION NO.11
 STA 43+50.00 TO 44+17.38 -L-
 STA 71+94.00 TO 73+85.00 -L-
 STA 81+00.00 TO 83+02.00 -L-

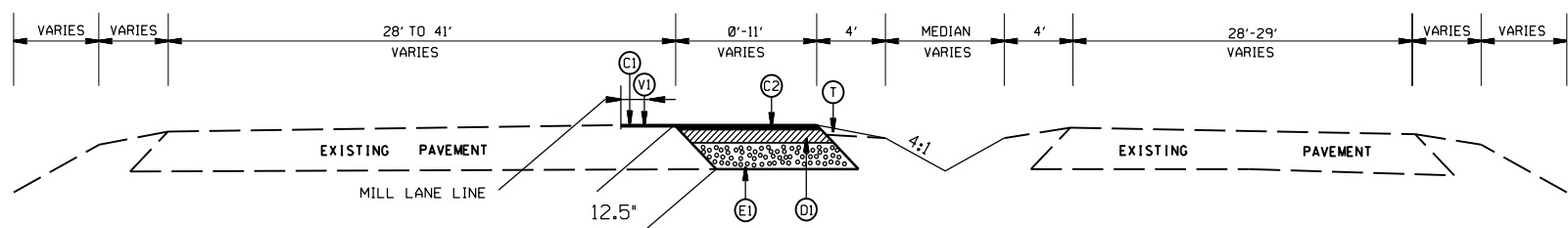

TYPICAL SECTION NO.10
 STA 39+93.00 TO 43+50.00 -L-
 STA 70+89.89 TO 71+94.00 -L-
 STA 78+57.00 TO 81+00.00 -L-

PAVEMENT SCHEDULE

(C1)	PROP. APPROX. 1½" ASPHALT CONC. SURFACE COURSE, TYPE S9.5B, AT AN AVERAGE RATE OF 168 LBS. PER SQ. YD.
(C2)	PROP. APPROX. 3" ASPHALT CONC. SURFACE COURSE, TYPE S9.5B, AT AN AVERAGE RATE OF 168 LBS. PER SQ. YD., IN TWO EQUAL LAYERS
(D1)	PROP. APPROX. 4" ASPHALT CONC. BINDER COURSE, TYPE I19.0C, AT AN AVERAGE RATE OF 456 LBS. PER SQ. YD.
(E1)	PROP. APPROX. 5.5" ASPHALT CONC. BASE COURSE, TYPE B25.0C, AT AN AVERAGE RATE OF 627 LBS. PER SQ. YD.
(R1)	PROP. 5" MONOLITHIC ISLAND (SURFACE MOUNTED)
(T)	EARTH MATERIAL
(V1)	MILLING ASPHALT PAVEMENT, 1.5" IN DEPTH

SIGNALIZED RCI ON NC 16
 AT OLD PLANK RD.(SR-2006) AND
 PLEASANT GROVE RD.(SR-2008)

SCALE	N/A
DATE	3-2022
DWG. BY	TBL
DESIGN BY	JCB
APPROVED	JDH



REVISIONS	

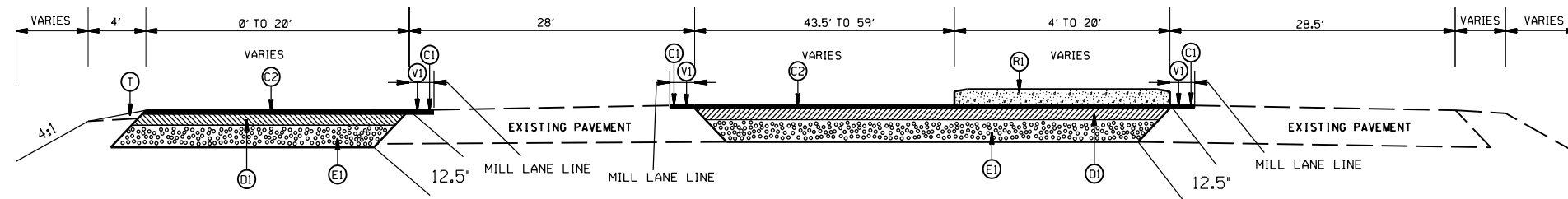

TYPICAL SECTION NO.15
 STA 48+42.00 TO 48+78.50 -L-
 STA 85+86.87 TO 86+27.51 -L-

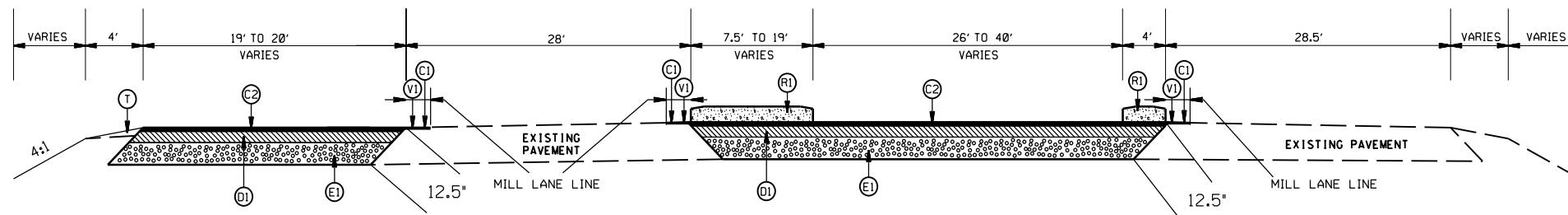

TYPICAL SECTION NO.14
 STA 48+37.00 TO 48+42.00 -L-
 STA 85+86.87 TO 85+92.00 -L-

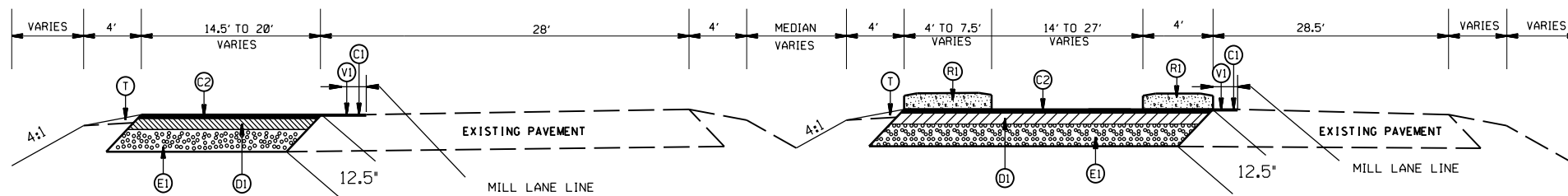

TYPICAL SECTION NO.13
 STA 47+94.00 TO 48+37.00 -L-
 STA 85+44.00 TO 85+86.87 -L-

PAVEMENT SCHEDULE

(C1)	PROP. APPROX. 1½" ASPHALT CONC. SURFACE COURSE, TYPE S9.5B, AT AN AVERAGE RATE OF 168 LBS. PER SQ. YD.
(C2)	PROP. APPROX. 3" ASPHALT CONC. SURFACE COURSE, TYPE S9.5B, AT AN AVERAGE RATE OF 168 LBS. PER SQ. YD., IN TWO EQUAL LAYERS
(D1)	PROP. APPROX. 4" ASPHALT CONC. BINDER COURSE, TYPE I19.0C, AT AN AVERAGE RATE OF 456 LBS. PER SQ. YD.
(E1)	PROP. APPROX. 5.5" ASPHALT CONC. BASE COURSE, TYPE B25.0C, AT AN AVERAGE RATE OF 627 LBS. PER SQ. YD.
(R1)	PROP. 5" MONOLITHIC ISLAND (SURFACE MOUNTED)
(T)	EARTH MATERIAL
(V1)	MILLING ASPHALT PAVEMENT, 1.5" IN DEPTH

SIGNALIZED RCI ON NC 16
 AT OLD PLANK RD.(SR-2006) AND
 PLEASANT GROVE RD.(SR-2008)

SCALE	N/A		REVISIONS
DATE	3-2022		
DWG. BY	TBL		
DESIGN BY	JCB		
APPROVED	JDH		

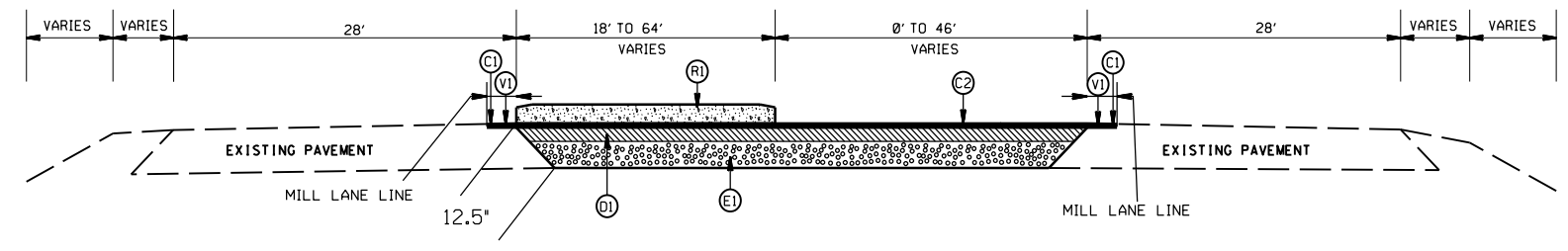

TYPICAL SECTION NO.19
STA 68+51.00 TO 68+57.47 -L-

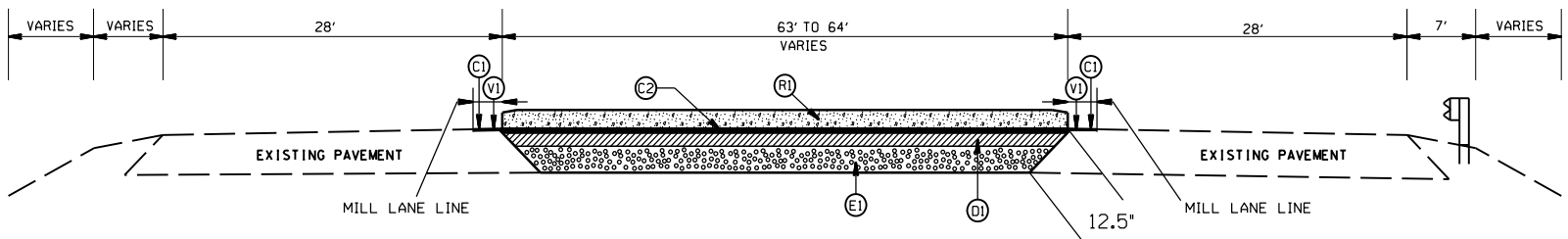

TYPICAL SECTION NO.18
STA 68+35.00 TO 68+51.00 -L-

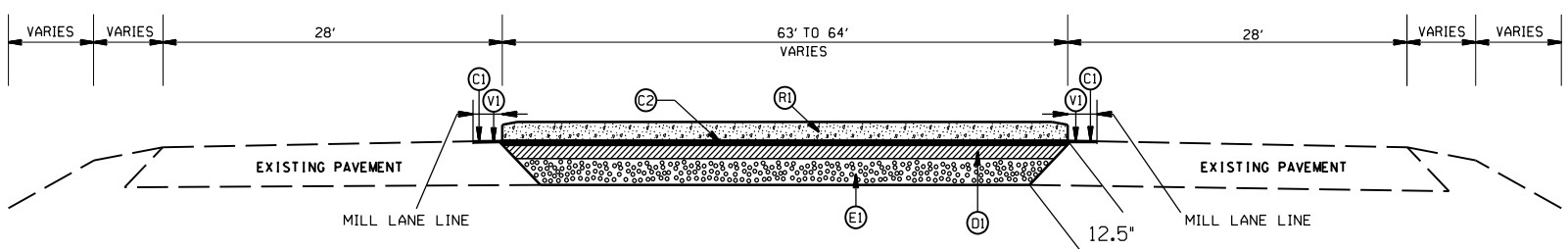

TYPICAL SECTION NO.17
STA 48+84.00 TO 49+00.00 -L-
STA 86+34.00 TO 86+50.00 -L-

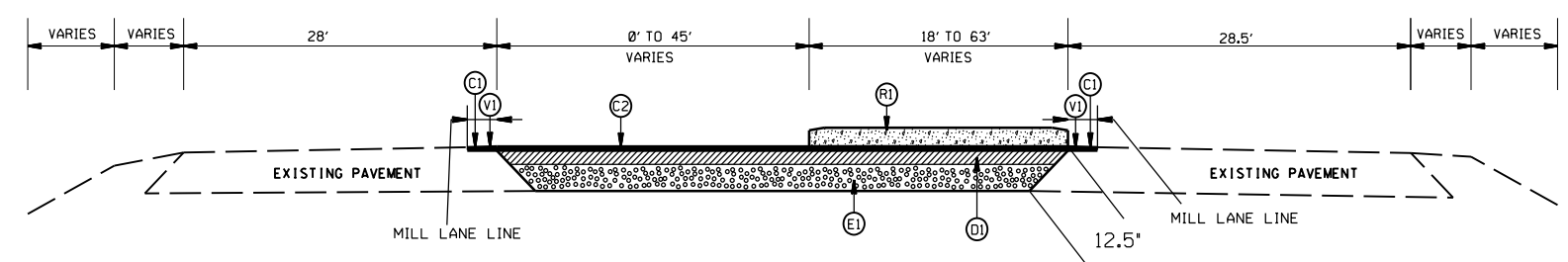

TYPICAL SECTION NO.16
STA 48+78.50 TO 48+84.00 -L-
STA 86+27.51 TO 86+34.00 -L-

PAVEMENT SCHEDULE

(C1)	PROP. APPROX. 1½" ASPHALT CONC. SURFACE COURSE, TYPE S9.5B, AT AN AVERAGE RATE OF 168 LBS. PER SQ. YD.
(C2)	PROP. APPROX. 3" ASPHALT CONC. SURFACE COURSE, TYPE S9.5B, AT AN AVERAGE RATE OF 168 LBS. PER SQ. YD., IN TWO EQUAL LAYERS
(D1)	PROP. APPROX. 4" ASPHALT CONC. BINDER COURSE, TYPE I19.0C, AT AN AVERAGE RATE OF 456 LBS. PER SQ. YD.
(E1)	PROP. APPROX. 5.5" ASPHALT CONC. BASE COURSE, TYPE B25.0C, AT AN AVERAGE RATE OF 627 LBS. PER SQ. YD.
(R1)	PROP. 5" MONOLITHIC ISLAND (SURFACE MOUNTED)
(T)	EARTH MATERIAL
(V1)	MILLING ASPHALT PAVEMENT, 1.5" IN DEPTH

SIGNALIZED RCI ON NC 16
AT OLD PLANK RD.(SR-2006) AND
PLEASANT GROVE RD.(SR-2008)

SCALE	N/A		REVISIONS
DATE	3-2022		
DWG. BY	TBL		
DESIGN BY	JCB		
APPROVED	JDH		

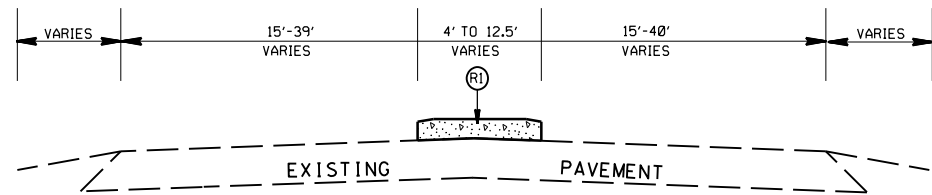

TYPICAL SECTION NO.23

STA 13+09.22 TO 14+00.00 -Y-
 STA 15+16.19 TO 16+04.00 -Y-
 STA 13+31.00 TO 14+19.74 -Y1-
 STA 15+37.79 TO 16+26.00 -Y1-

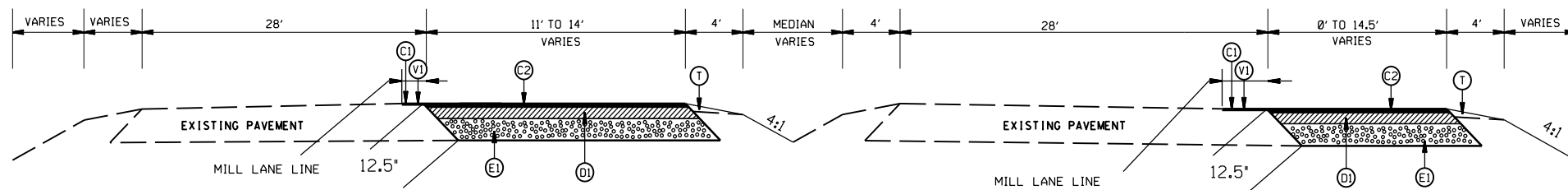

TYPICAL SECTION NO.22

STA 69+41.00 TO 70+80.89 -L-

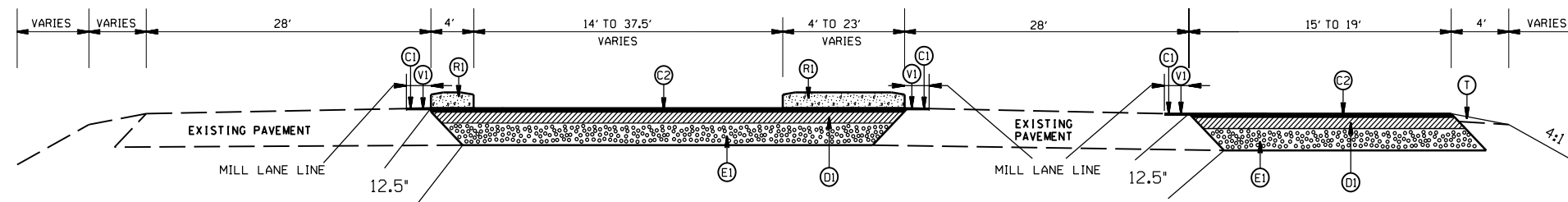

TYPICAL SECTION NO.21

STA 68+93.00 TO 69+41.00 -L-

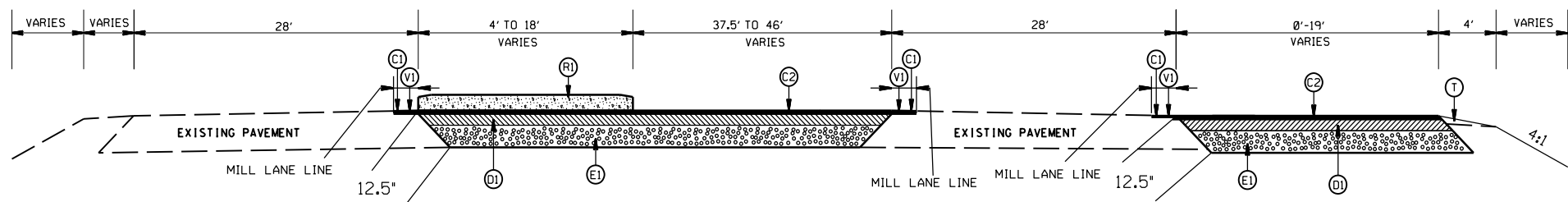

TYPICAL SECTION NO.20

STA 68+57.47 TO 68+93.00 -L-

PAVEMENT SCHEDULE

(C1)	PROP. APPROX. 1½" ASPHALT CONC. SURFACE COURSE, TYPE S9.5B, AT AN AVERAGE RATE OF 168 LBS. PER SQ. YD.
(C2)	PROP. APPROX. 3" ASPHALT CONC. SURFACE COURSE, TYPE S9.5B, AT AN AVERAGE RATE OF 168 LBS. PER SQ. YD., IN TWO EQUAL LAYERS
(D1)	PROP. APPROX. 4" ASPHALT CONC. BINDER COURSE, TYPE I19.0C, AT AN AVERAGE RATE OF 456 LBS. PER SQ. YD.
(E1)	PROP. APPROX. 5.5" ASPHALT CONC. BASE COURSE, TYPE B25.0C, AT AN AVERAGE RATE OF 627 LBS. PER SQ. YD.
(R1)	PROP. 5" MONOLITHIC ISLAND (SURFACE MOUNTED)
(T)	EARTH MATERIAL
(V1)	MILLING ASPHALT PAVEMENT, 1.5" IN DEPTH

SIGNALIZED RCI ON NC 16
 AT OLD PLANK RD.(SR-2006) AND
 PLEASANT GROVE RD.(SR-2008)

SCALE	N/A
DATE	3-2022
DWG. BY	TBL
DESIGN BY	JCB
APPROVED	JDH



REVISIONS

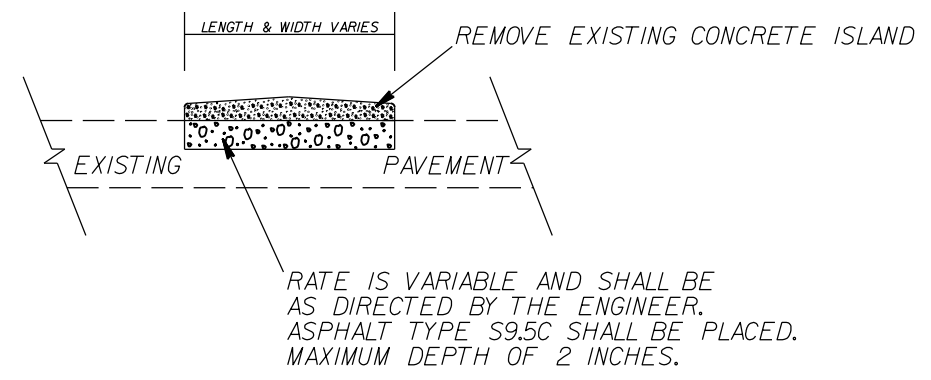

ISLAND PATCHING DETAIL

PAVEMENT SCHEDULE

(C1)	PROP. APPROX. 1½" ASPHALT CONC. SURFACE COURSE, TYPE S9.5B, AT AN AVERAGE RATE OF 168 LBS. PER SQ. YD.
(C2)	PROP. APPROX. 3" ASPHALT CONC. SURFACE COURSE, TYPE S9.5B, AT AN AVERAGE RATE OF 168 LBS. PER SQ. YD., IN TWO EQUAL LAYERS
(D1)	PROP. APPROX. 4" ASPHALT CONC. BINDER COURSE, TYPE I19.0C, AT AN AVERAGE RATE OF 456 LBS. PER SQ. YD.
(E1)	PROP. APPROX. 5.5" ASPHALT CONC. BASE COURSE, TYPE B25.0C, AT AN AVERAGE RATE OF 627 LBS. PER SQ. YD.
(R1)	PROP. 5" MONOLITHIC ISLAND (SURFACE MOUNTED)
(T)	EARTH MATERIAL
(V1)	MILLING ASPHALT PAVEMENT, 1.5" IN DEPTH

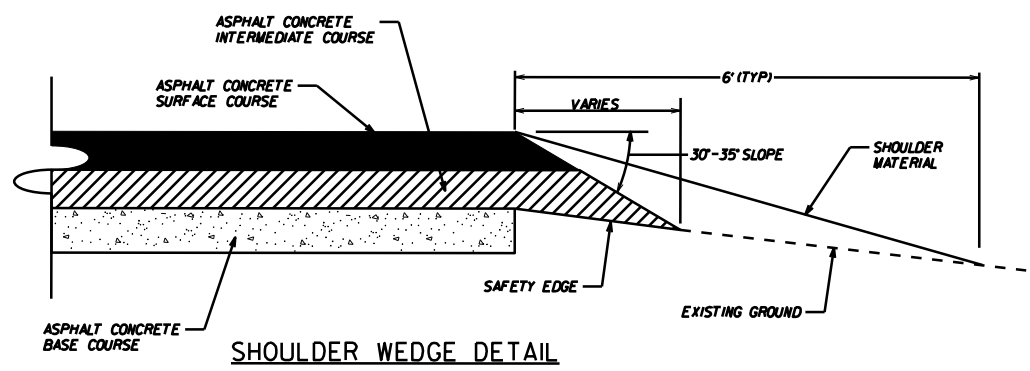

SHOULDER WEDGE DETAIL

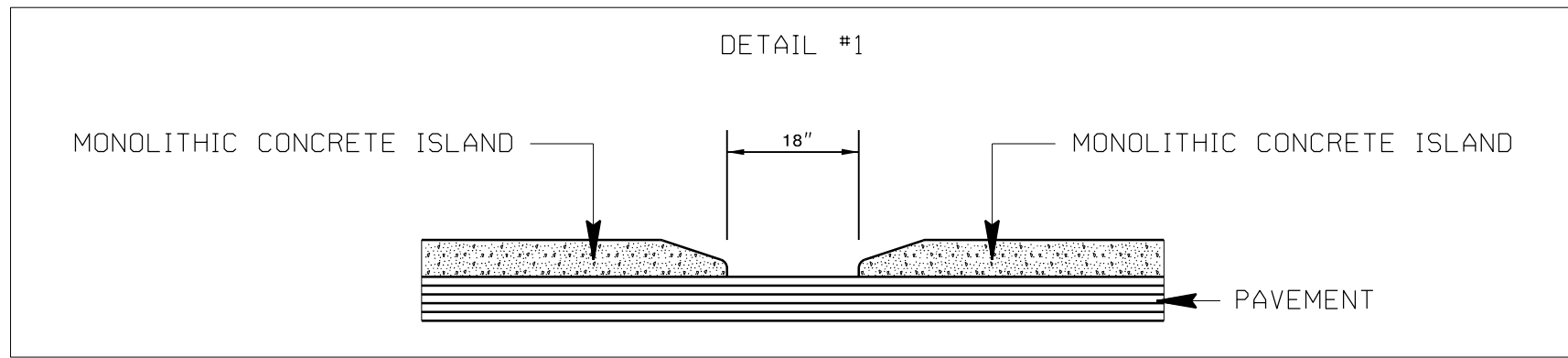

SIGNALIZED RCI ON NC 16
AT OLD PLANK RD. (SR-2006) AND
PLEASANT GROVE RD. (SR-2008)

SCALE	N/A		REVISIONS
DATE	3-2022		
DWG. BY	TBL		
DESIGN BY	JCB		
APPROVED	JDH		

PROJECT NO.	SHEET NO.
44856.3.39	4A
F.A. PROJECT NO. HSIP-00610651	

ROADWAY DESIGN ENGINEER

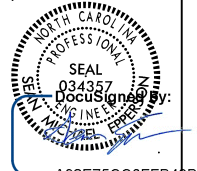

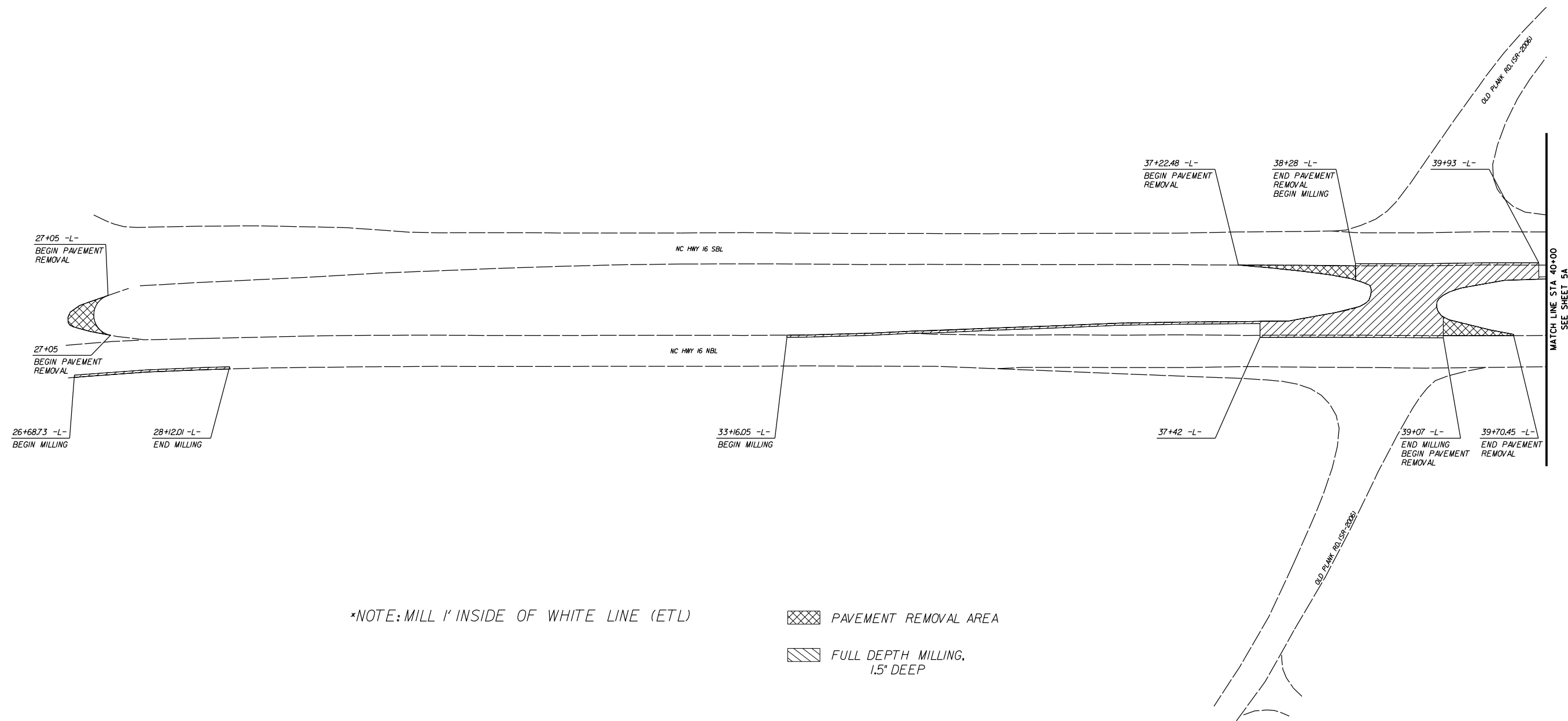

DocuSigner By: [Signature]

A92E75CC0FFB48B



*NOTE: MILL 1' INSIDE OF WHITE LINE (ETL)

-  PAVEMENT REMOVAL AREA
-  FULL DEPTH MILLING, 1.5" DEEP

SIGNALIZED RCI ON NC 16
AT OLD PLANK RD.(SR-2006) AND
PLEASANT GROVE RD.(SR-2008)

SCALE	1"=50'		REVISIONS
DATE	3-2022		
DWG. BY	TBL		
DESIGN BY	TBL		
APPROVED	JDH		

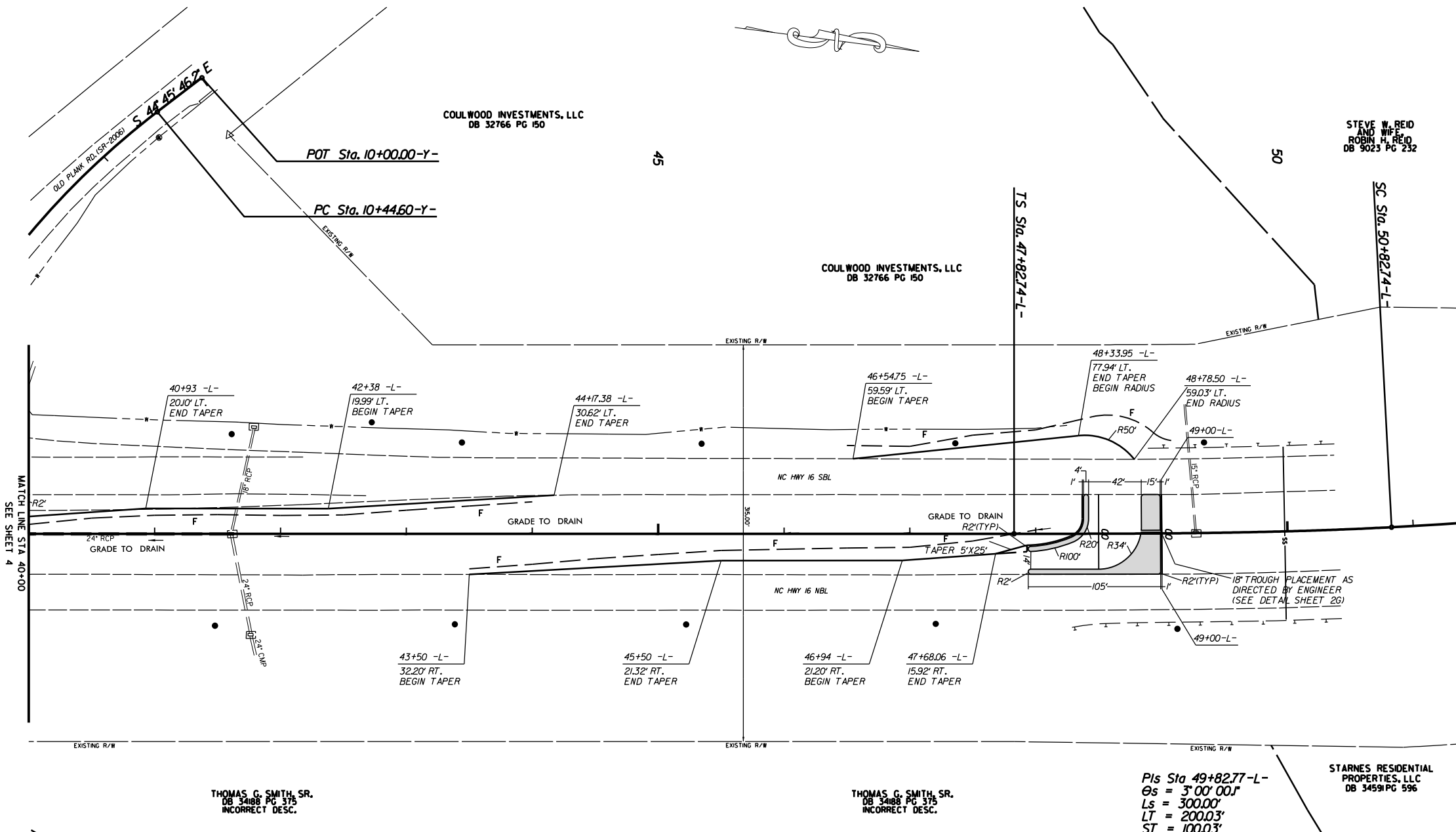
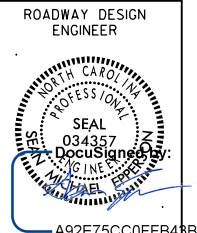

NOTE: INCIDENTAL MILL APPROX. 25' AT EACH TIE IN TO PROVIDE A SMOOTH TRANSITION TO THE EXISTING ASPHALT PAVEMENT.

SIGNALIZED RCI ON NC 16
AT OLD PLANK RD.(SR-2006) AND
PLEASANT GROVE RD.(SR-2008)

SCALE	1"=50'		REVISIONS
DATE	3-2022		
DWG. BY	TBL		
DESIGN BY	TBL		
APPROVED	JDH		

PROJECT NO.	SHEET NO.
44856.3.39	5A
F.A. PROJECT NO. HSIP-001610651	

ROADWAY DESIGN ENGINEER

A92E75CC0FFB48B

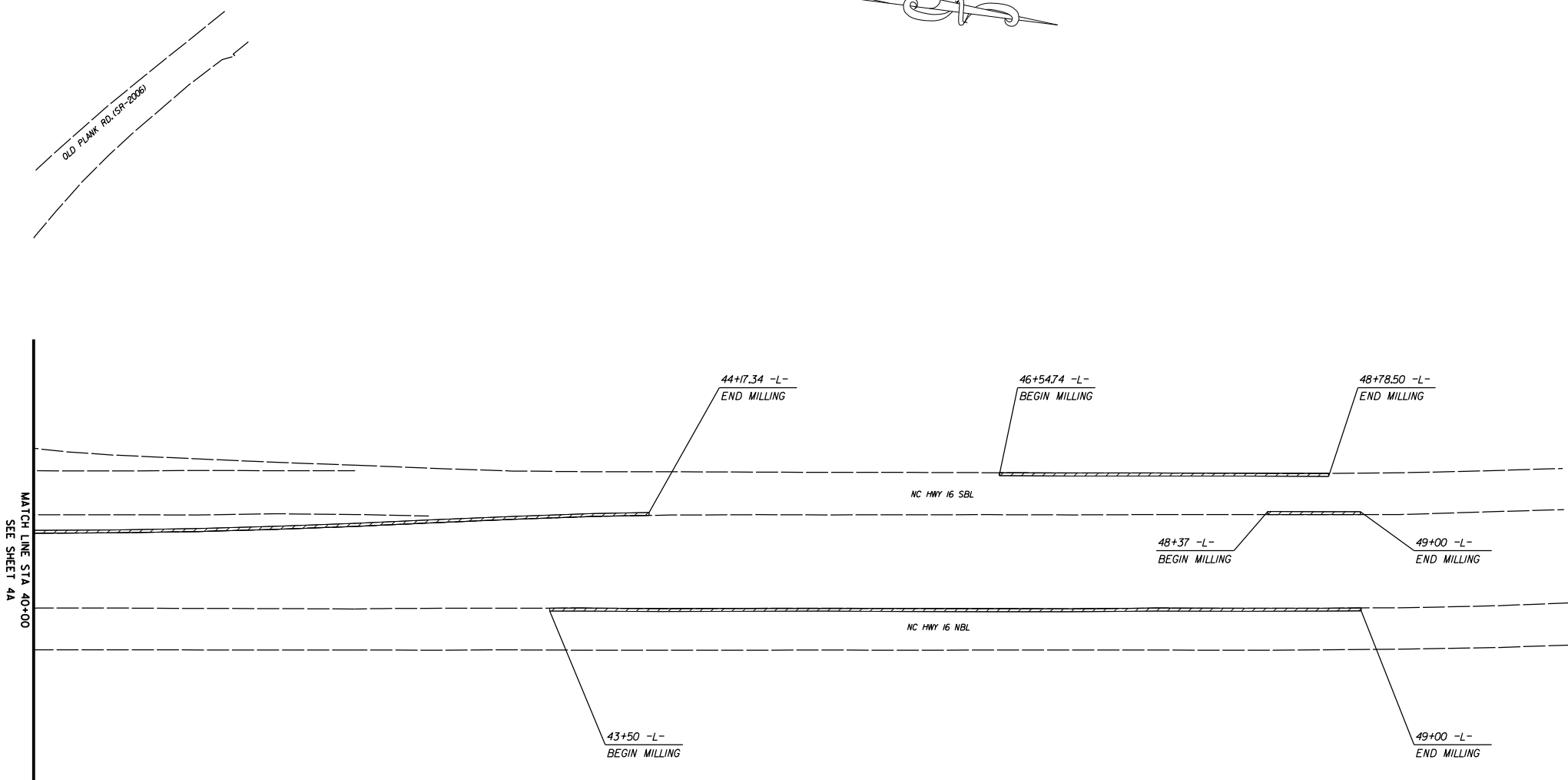

*NOTE: MILL 1' INSIDE OF WHITE LINE (ETL)

- PAVEMENT REMOVAL AREA
- FULL DEPTH MILLING, 1.5" DEEP

SIGNALIZED RCI ON NC 16
AT OLD PLANK RD.(SR-2006) AND
PLEASANT GROVE RD.(SR-2008)

SCALE	1"=50'		REVISIONS
DATE	3-2022		
DWG. BY	TBL		
DESIGN BY	TBL		
APPROVED	JDH		

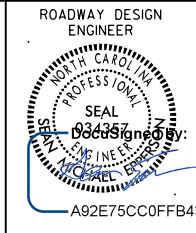

PI Sta 11+04.70-Y1-
 $\Delta = 3^\circ 22' 43.2''$ (LT)
 $D = 136' 50.3''$
 $L = 209.34'$
 $T = 104.70'$
 $R = 3550.00'$

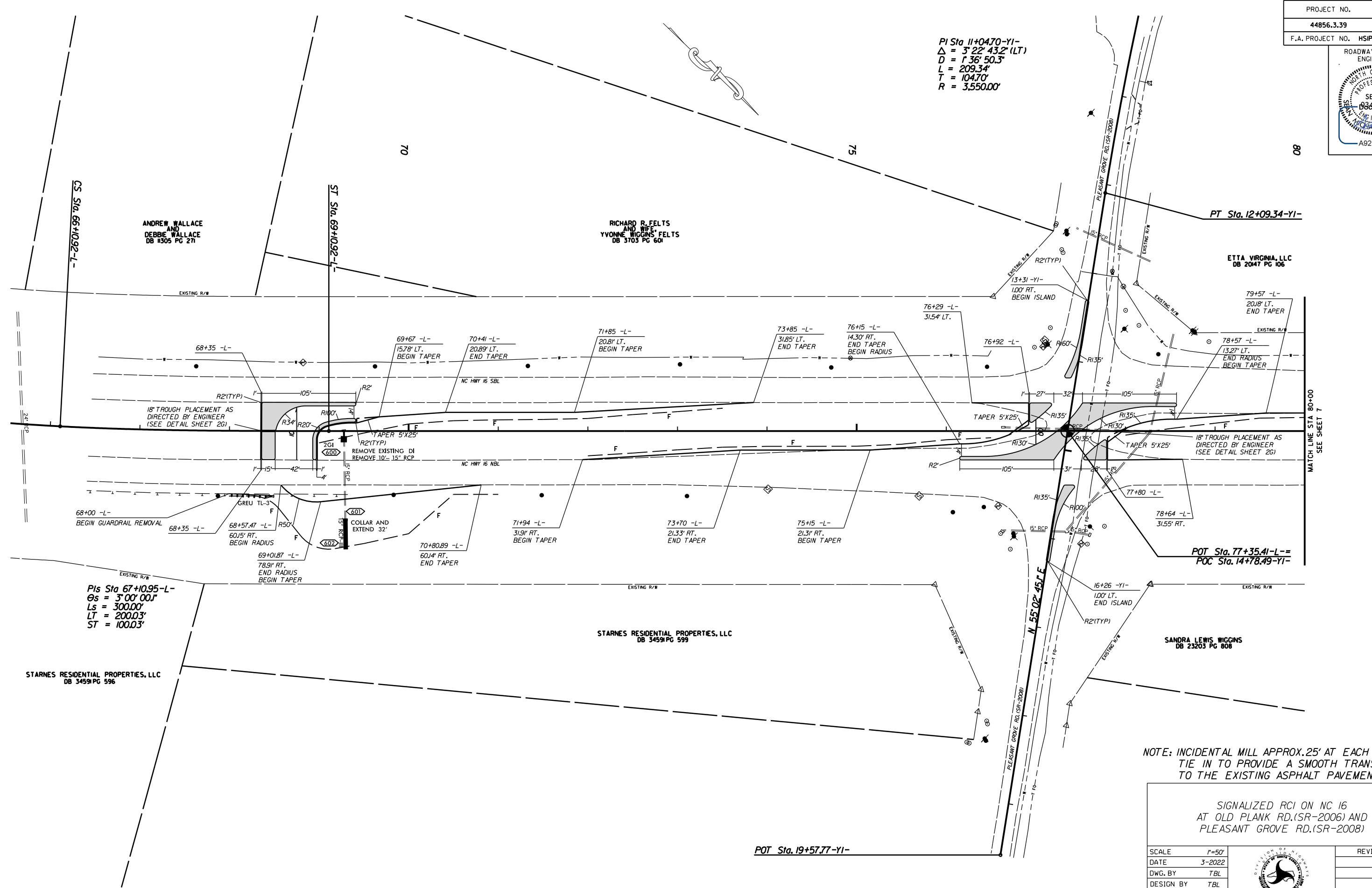

PIs Sta 67+10.95-L-
 $\theta_s = 3^\circ 00' 00''$
 $L_s = 300.00'$
 $LT = 200.03'$
 $ST = 100.03'$

NOTE: INCIDENTAL MILL APPROX. 25' AT EACH TIE IN TO PROVIDE A SMOOTH TRANSITION TO THE EXISTING ASPHALT PAVEMENT.

SIGNALIZED RCI ON NC 16 AT OLD PLANK RD. (SR-2006) AND PLEASANT GROVE RD. (SR-2008)	
SCALE	1"=50'
DATE	3-2022
DWG. BY	TBL
DESIGN BY	TBL
APPROVED	JDH
REVISIONS	



POT Sta. 19+57.77-Y1-

PROJECT NO.	SHEET NO.
44856.3.39	6A
F.A. PROJECT NO. HSIP-00610651	

ROADWAY DESIGN ENGINEER

SEAL
034357
Michael J. Hines
Professional Engineer
State of North Carolina

A92E75CC0FFB43E

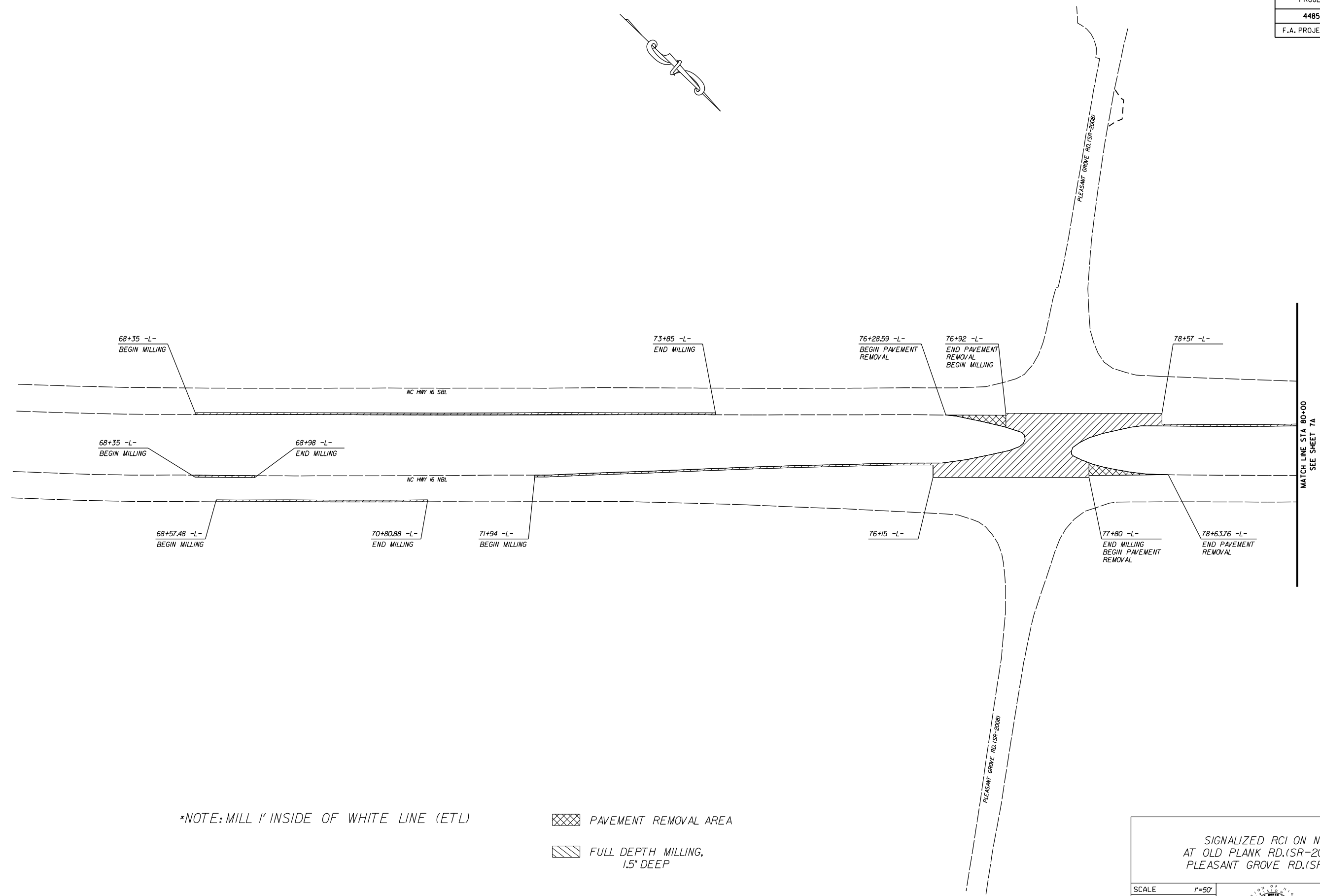

*NOTE: MILL 1' INSIDE OF WHITE LINE (ETL)

- PAVEMENT REMOVAL AREA
- FULL DEPTH MILLING, 1.5' DEEP

SIGNALIZED RCI ON NC 16
AT OLD PLANK RD.(SR-2006) AND
PLEASANT GROVE RD.(SR-2008)

SCALE	1"=50'		REVISIONS
DATE	3-2022		
DWG. BY	TBL		
DESIGN BY	TBL		
APPROVED	JDH		

PROJECT NO.	SHEET NO.
44856.3.39	7
F.A. PROJECT NO. HSIP-006(065)	

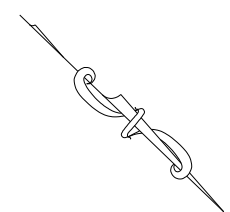
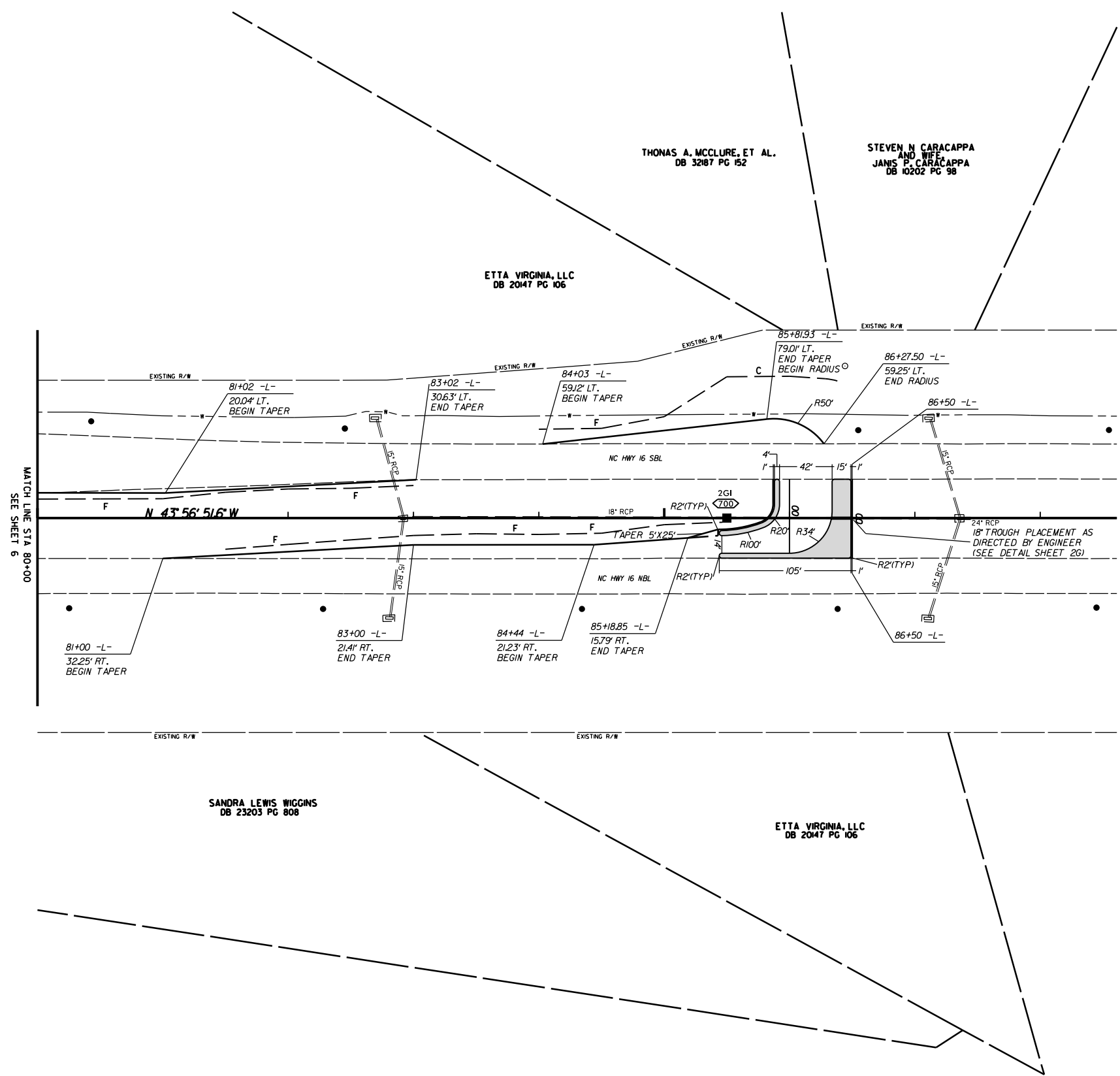
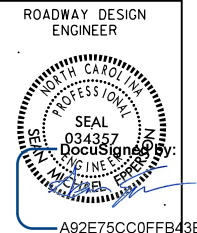

NOTE: INCIDENTAL MILL APPROX. 25' AT EACH TIE IN TO PROVIDE A SMOOTH TRANSITION TO THE EXISTING ASPHALT PAVEMENT.

SIGNALIZED RCI ON NC 16
AT OLD PLANK RD. (SR-2006) AND
PLEASANT GROVE RD. (SR-2008)

SCALE	1"=50'		REVISIONS
DATE	3-2022		
DWG. BY	TBL		
DESIGN BY	TBL		
APPROVED	JDH		

PROJECT NO.	SHEET NO.
44856.3.39	7A
F.A. PROJECT NO. HSIP-001610651	

ROADWAY DESIGN
ENGINEER



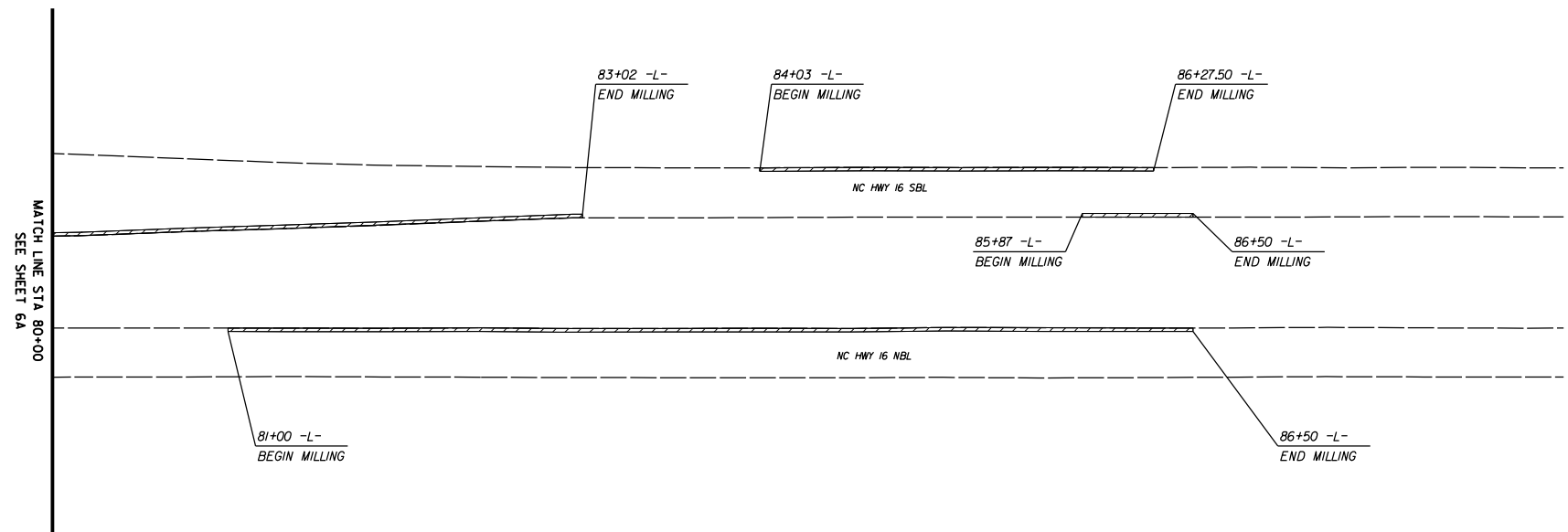
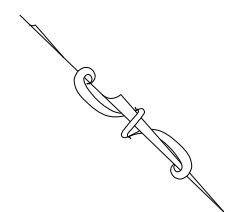

SEAL
03668
MICHAEL B. MCNEAL
ENGINEER
STATE OF NORTH CAROLINA

A92E75CC0FFB3...



*NOTE: MILL 1' INSIDE OF WHITE LINE (ETL)

-  PAVEMENT REMOVAL AREA
-  FULL DEPTH MILLING, 1.5" DEEP

SIGNALIZED RCI ON NC 16
AT OLD PLANK RD.(SR-2006) AND
PLEASANT GROVE RD.(SR-2008)

SCALE	1"=50'		REVISIONS
DATE	3-2022		
DWG. BY	TBL		
DESIGN BY	TBL		
APPROVED	JDH		

TIP PROJECT: W-5710AK

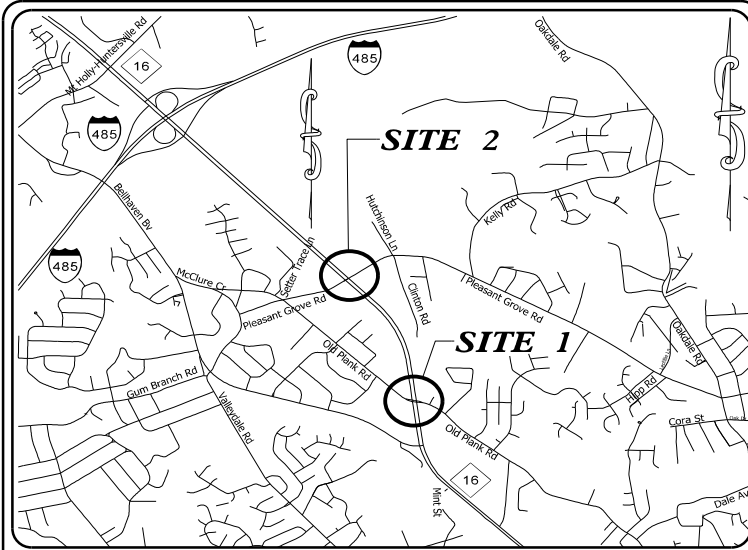

VICINITY MAP
NOT TO SCALE

STATE OF NORTH CAROLINA
DIVISION OF HIGHWAYS
**PLAN FOR PROPOSED
HIGHWAY EROSION CONTROL
MECKLENBURG COUNTY**

**LOCATION: INTERSECTIONS ON NC 16 AT OLD PLANK RD.(SR-2006)
AND PLEASANT GROVE RD.(SR-2008)**

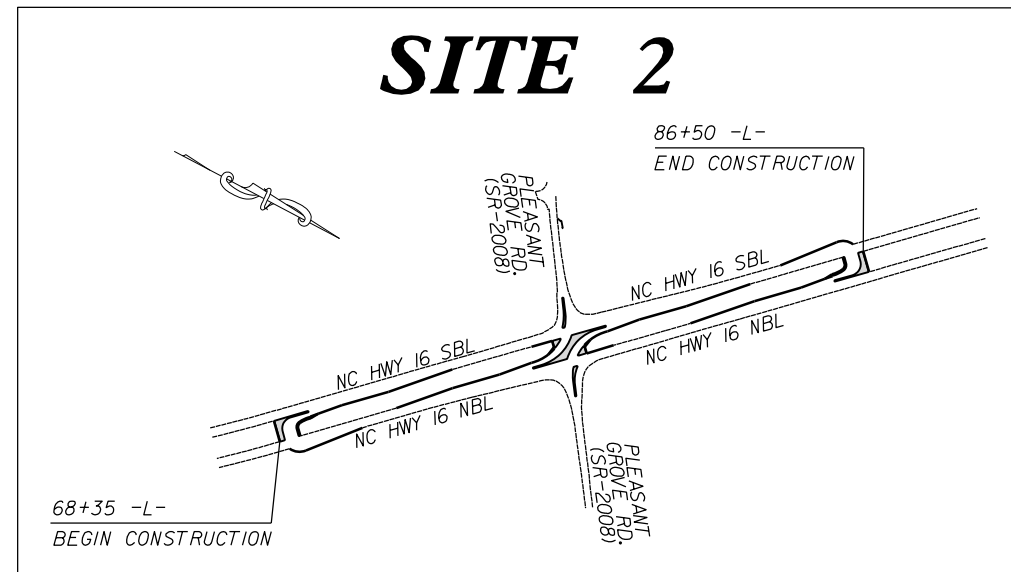
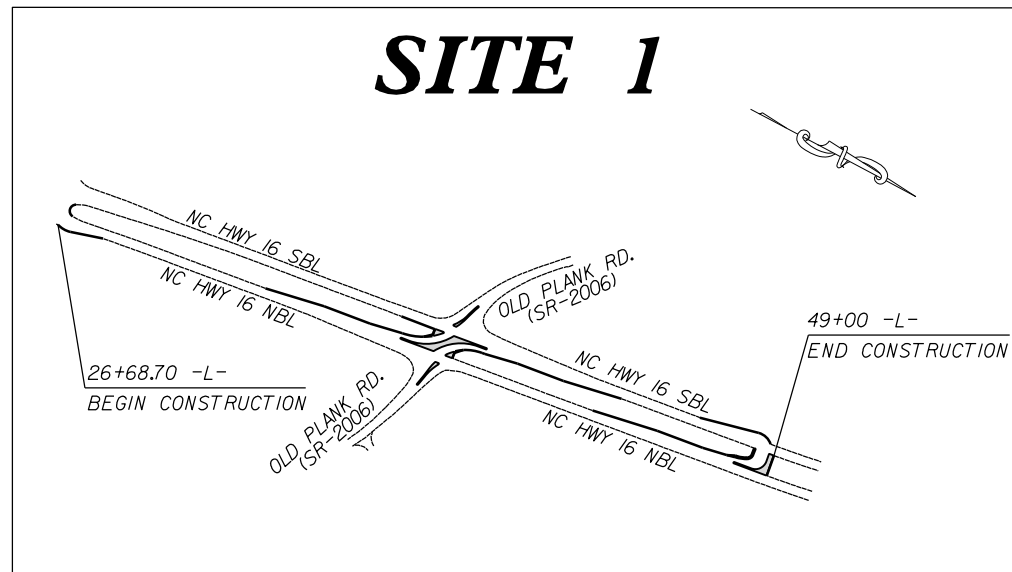

INSTALL PERIMETER EROSION CONTROL
MEASURES DURING INITIAL CLEARING PHASE

STATE	STATE PROJECT REFERENCE NO.	SHEET NO.	TOTAL SHEETS
N.C.	W-5710AK	EC-1	
STATE PROJ. NO.	F.A. PROJ. NO.	DESCRIPTION	
44856.1.39	HSIP-0016(065)	P.E.	
44856.2.39	HSIP-0016(065)	RW	
44856.3.39	HSIP-0016(065)	CONST.	

EROSION AND SEDIMENT CONTROL MEASURES

Sid. #	Description	Symbol
1630.05	Temporary Silt Ditch	TD
1630.05	Temporary Diversion	TD
1605.01	Temporary Silt Fence	TSF
1606.01	Special Sediment Control Fence	SSCF
1622.01	Temporary Berms and Slope Drains	TBSD
1630.02	Silt Basin Type B	SB
1633.01	Temporary Rock Silt Check Type-A	TRSCA
	Temporary Rock Silt Check Type-A with Matting and Polyacrylamide (PAM)	TRSCA-PAM
1633.02	Temporary Rock Silt Check Type-B	TRSCB
	Wattle / Coir Fiber Wattle	WF
	Wattle / Coir Fiber Wattle with Polyacrylamide (PAM)	WF-PAM
1634.01	Temporary Rock Sediment Dam Type-A	TRSDA
1634.02	Temporary Rock Sediment Dam Type-B	TRSDB
1635.01	Rock Pipe Inlet Sediment Trap Type-A	RPISTRA
1635.02	Rock Pipe Inlet Sediment Trap Type-B	RPISTRB
1630.04	Stilling Basin	SB
1630.06	Special Stilling Basin	SSB
	Rock Inlet Sediment Trap:	
1632.01	Type A	RA
1632.02	Type B	RB
1632.03	Type C	RC
	Skimmer Basin	SKB
	Tiered Skimmer Basin	TSKB
	Infiltration Basin	IB

**THIS PROJECT CONTAINS
EROSION CONTROL PLANS
FOR CLEARING AND
GRUBBING PHASE OF
CONSTRUCTION.**

**HIGH QUALITY WATER(S) EXIST
ON THIS PROJECT**
*High Quality Water Zone(s) Exist
From Sta. Begin Project
to Sta. End Project
Refer To E. C. Special Provisions
for Special Considerations.*

GRAPHIC SCALE



THESE EROSION AND SEDIMENT CONTROL PLANS COMPLY WITH
THE APPLICABLE REGULATIONS SET FORTH BY THE NCG-010000
GENERAL CONSTRUCTION PERMIT EFFECTIVE APRIL 1, 2019
AND ISSUED BY THE NORTH CAROLINA DEPARTMENT OF
ENVIRONMENTAL QUALITY DIVISION OF WATER RESOURCES.



Prepared In the Office of:
DDC UNIT DIVISION 10
DEPARTMENT OF TRANSPORTATION
DIVISION OF HIGHWAYS

Designed by:

JASON BROOKS

4369

NAME

LEVEL III CERTIFICATION NO.

Roadway Standard Drawings

The following roadway english standards as appear in "Roadway Standard Drawings"- Roadway Design Unit - N. C. Department of Transportation - Raleigh, N. C., dated January 2018 and the latest revision thereto are applicable to this project and by reference hereby are considered a part of these plans.

1604.01 Railroad Erosion Control Detail	1632.01 Rock Inlet Sediment Trap Type A
1605.01 Temporary Silt Fence	1632.02 Rock Inlet Sediment Trap Type J
1606.01 Special Sediment Control Fence	1632.03 Rock Inlet Sediment Trap Type C
1607.01 Gravel Construction Entrance	1633.01 Temporary Rock Silt Check Type A
1622.01 Temporary Berms and Slope Drains	1633.02 Temporary Rock Silt Check Type J
1630.01 Riser Basin	1634.01 Temporary Rock Sediment Dam Type A
1630.02 Silt Basin Type J	1634.02 Temporary Rock Sediment Dam Type J
1630.03 Temporary Silt Ditch	1635.01 Rock Pipe Inlet Sediment Dam Type A
1630.04 Stilling Basin	1635.02 Rock Pipe Inlet Sediment Trap Type J
1630.05 Temporary Diversion	1640.01 Coir Fiber Wattle
1630.06 Special Stilling Basin	1645.01 Temporary Stream Crossing
1631.01 Matting Installation	

WATTLE WITH POLYACRYLAMIDE (PAM) DETAIL

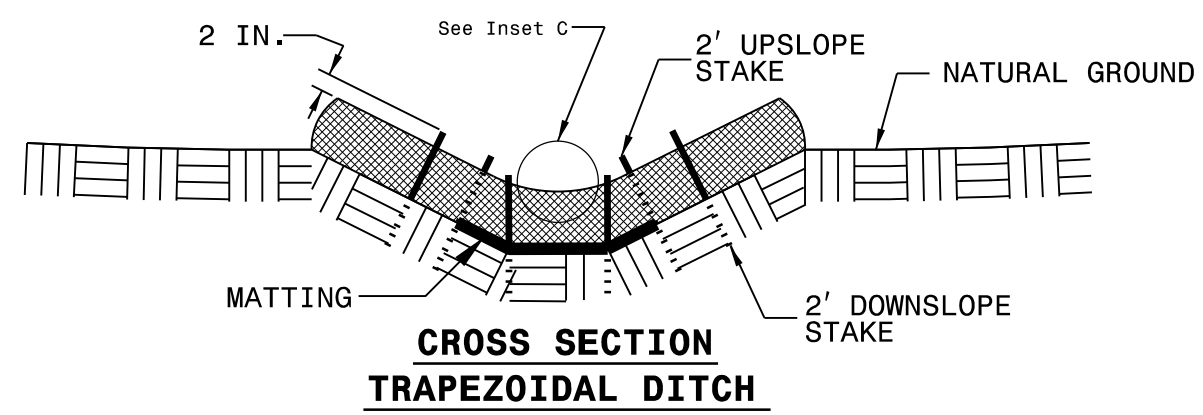
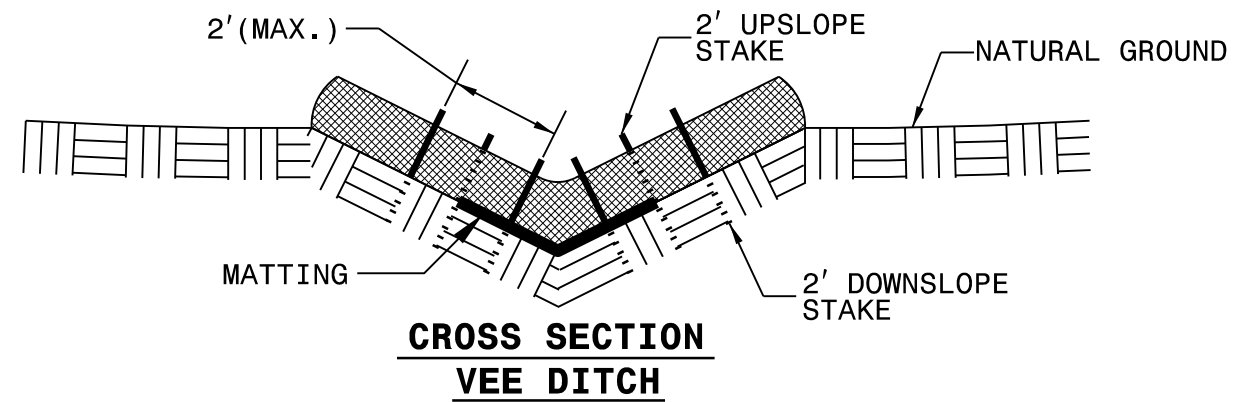
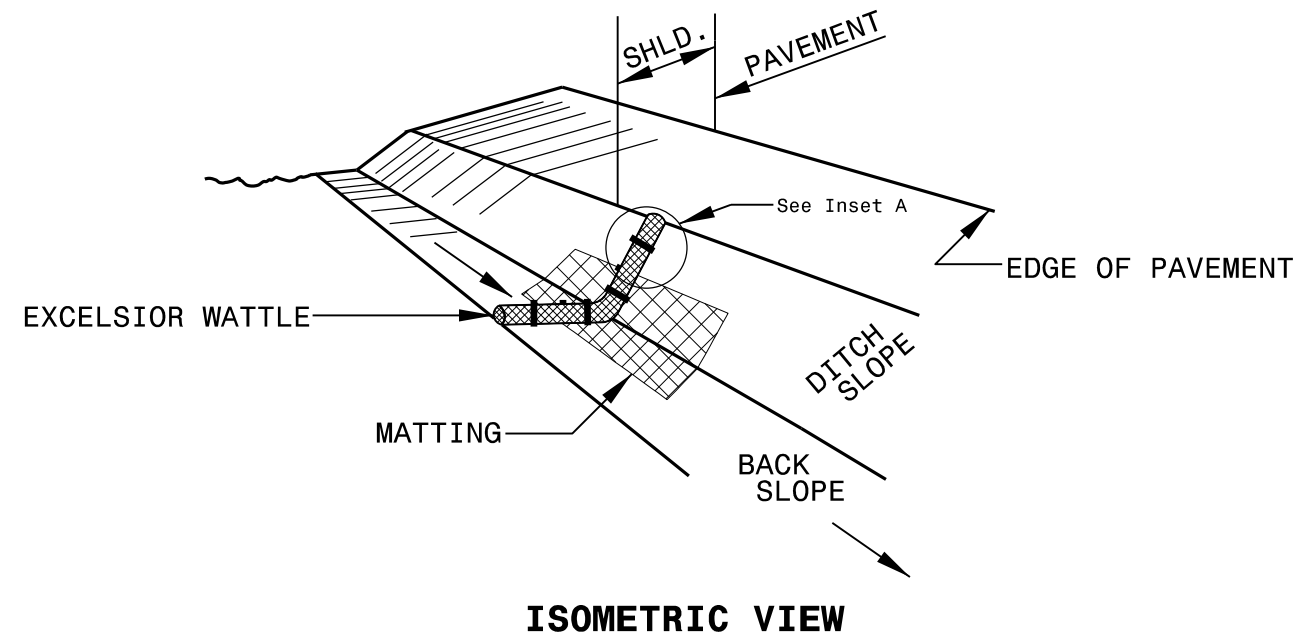

NOTES:

USE MINIMUM 12 IN. DIAMETER EXCELSIOR WATTLE.

USE 2 FT. WOODEN STAKES WITH A 2 IN. BY 2 IN. NOMINAL CROSS SECTION.

ONLY INSTALL WATTLE(S) TO A HEIGHT IN DITCH SO FLOW WILL NOT WASH AROUND WATTLE AND SCOUR DITCH SLOPES AND AS DIRECTED.

INSTALL A MINIMUM OF 2 UPSLOPE STAKES AND 4 DOWNSLOPE STAKES AT AN ANGLE TO WEDGE WATTLE TO BOTTOM OF DITCH.

PROVIDE STAPLES MADE OF 0.125 IN. DIAMETER STEEL WIRE FORMED INTO A U SHAPE NOT LESS THAN 12" IN LENGTH.

INSTALL STAPLES APPROXIMATELY EVERY 1 LINEAR FOOT ON BOTH SIDES OF WATTLE AND AT EACH END TO SECURE IT TO THE SOIL.

INSTALL MATTING IN ACCORDANCE WITH SECTION 1631 OF THE STANDARD SPECIFICATIONS.

PRIOR TO POLYACRYLAMIDE (PAM) APPLICATION, OBTAIN A SOIL SAMPLE FROM PROJECT LOCATION, AND FROM OFFSITE MATERIAL, AND ANALYZE FOR APPROPRIATE PAM FLOCCULANT TO BE APPLIED TO EACH WATTLE.

INITIALLY APPLY 2 OUNCES OF ANIONIC OR NEUTRALLY CHARGED PAM OVER WATTLE WHERE WATER WILL FLOW AND 1 OUNCE OF PAM ON MATTING ON EACH SIDE OF WATTLE. REAPPLY PAM AFTER EVERY RAINFALL EVENT THAT IS EQUAL TO OR EXCEEDS 0.50 IN.

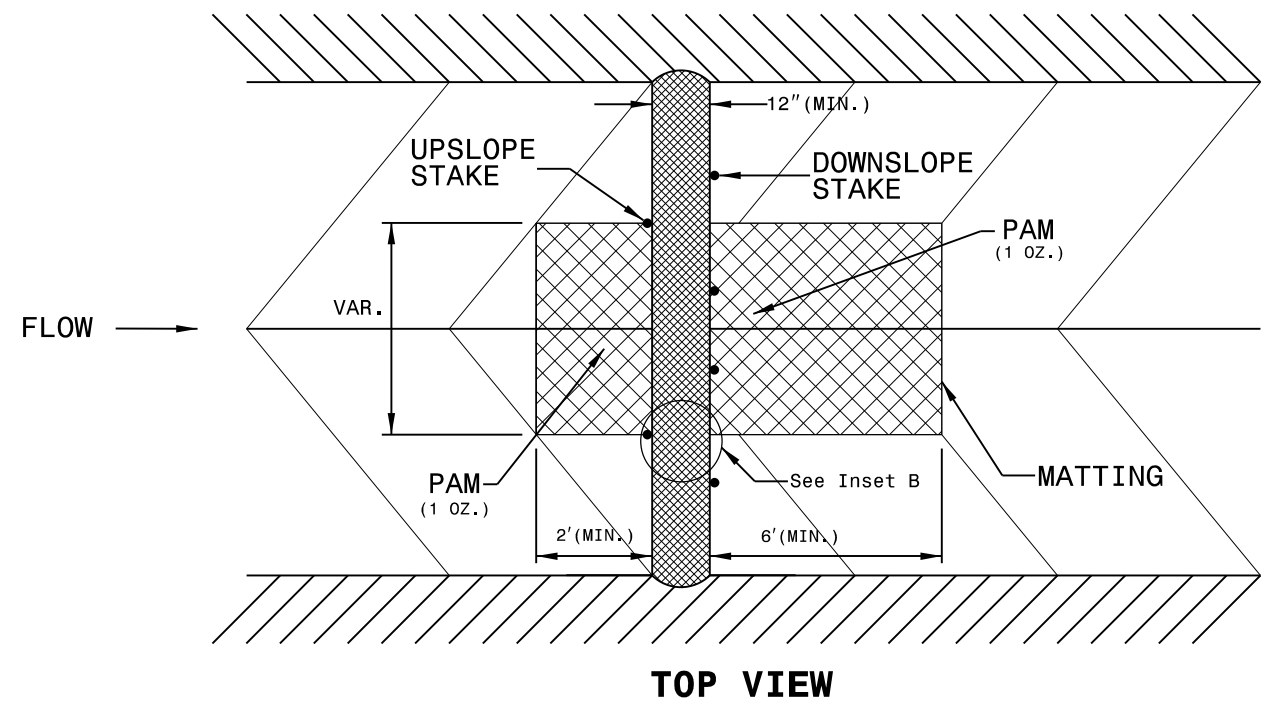
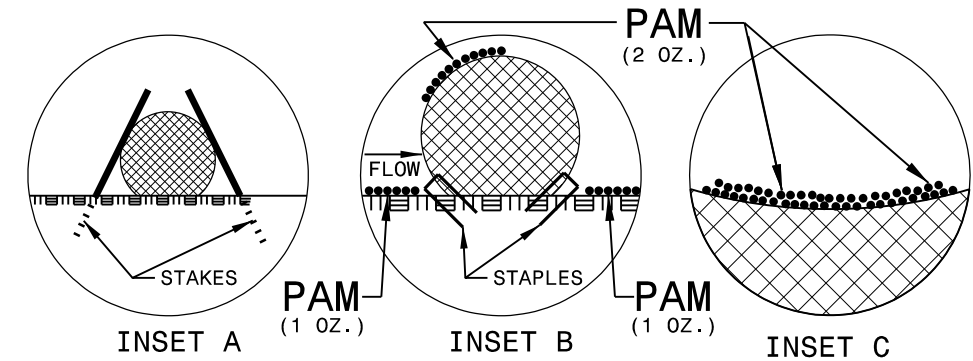

MATTING INSTALLATION DETAIL

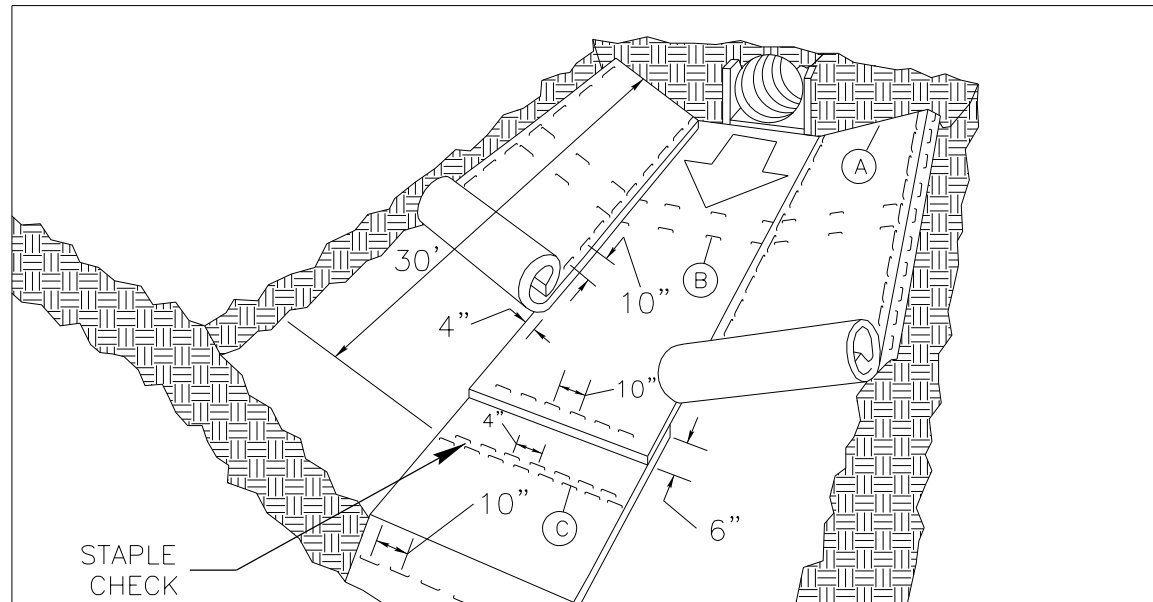

MATTING IN DITCHES

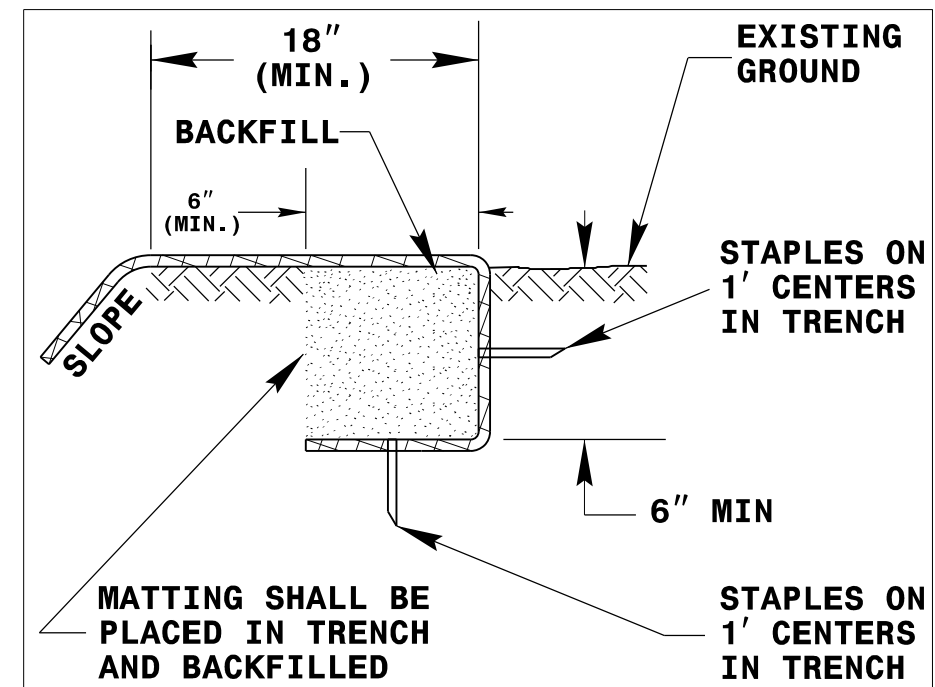
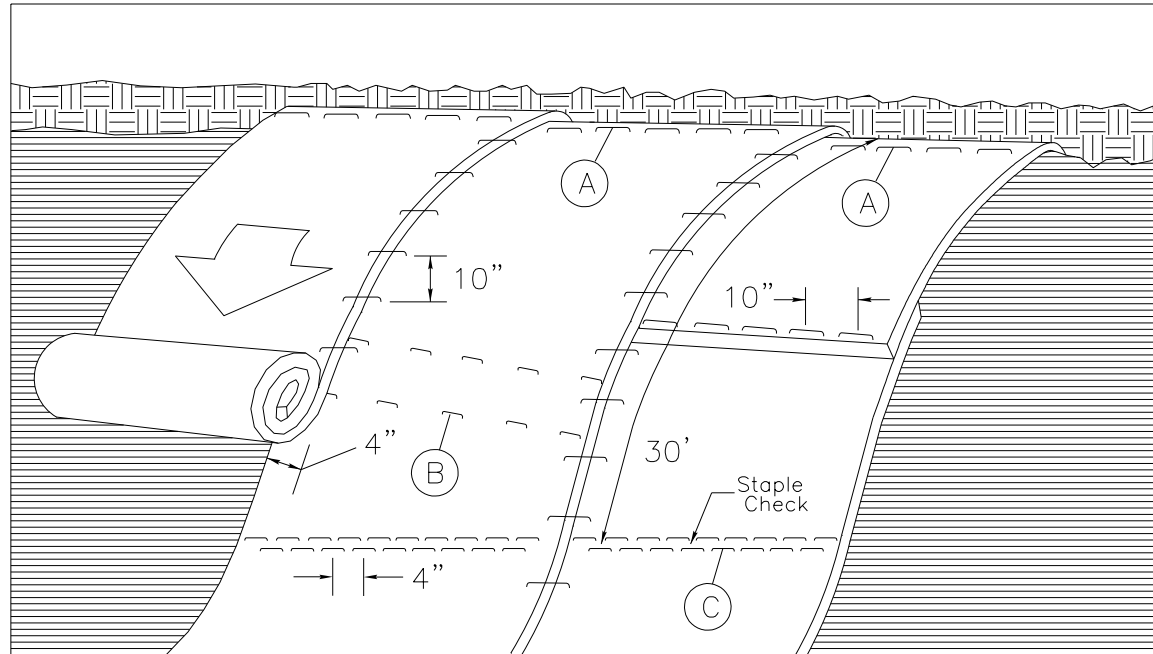

DIAGRAM (A)



MATTING ON SLOPES

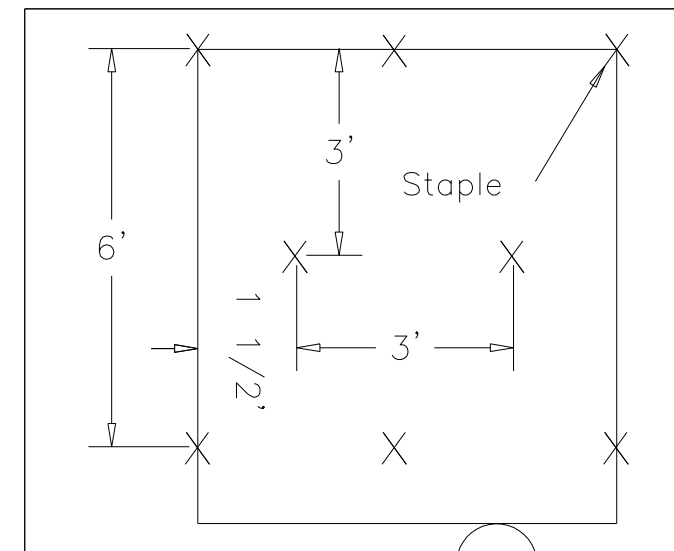

DIAGRAM (B)

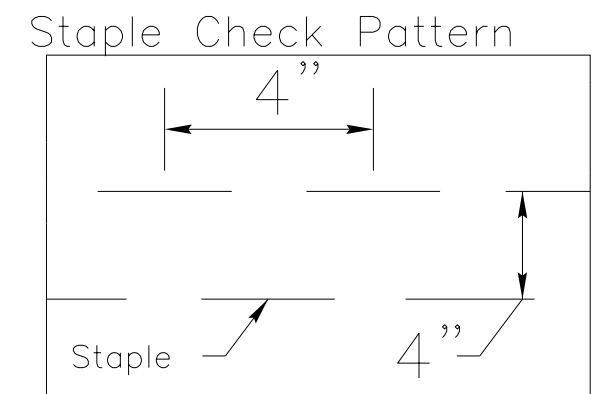

DIAGRAM (C)

NOTES:

THIS DETAIL APPLIES TO STRAW, EXCELSIOR, AND PERMANENT SOIL REINFORCEMENT MAT (PSRM) INSTALLATION.

STAPLES SHALL BE NO. 11 GAUGE STEEL WIRE FORMED INTO A "U" SHAPE WITH A MINIMUM THROAT WIDTH OF 1 INCH AND NOT LESS THAN 6 INCHES IN LENGTH.

NOT TO SCALE

PROJECT REFERENCE NO. <i>X-XXXX</i>	SHEET NO. <i>EC-XX/CONST.XX</i>
RW SHEET NO.	
ROADWAY DESIGN ENGINEER	HYDRAULICS ENGINEER

ONSITE CONCRETE WASHOUT STRUCTURE WITH LINER

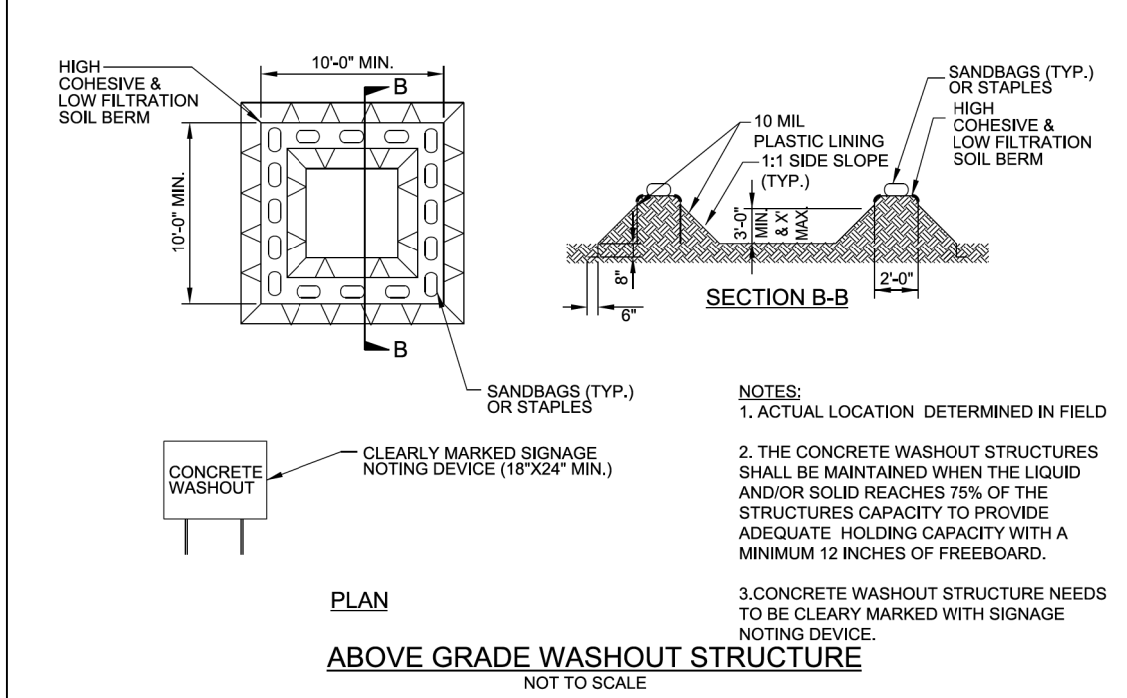
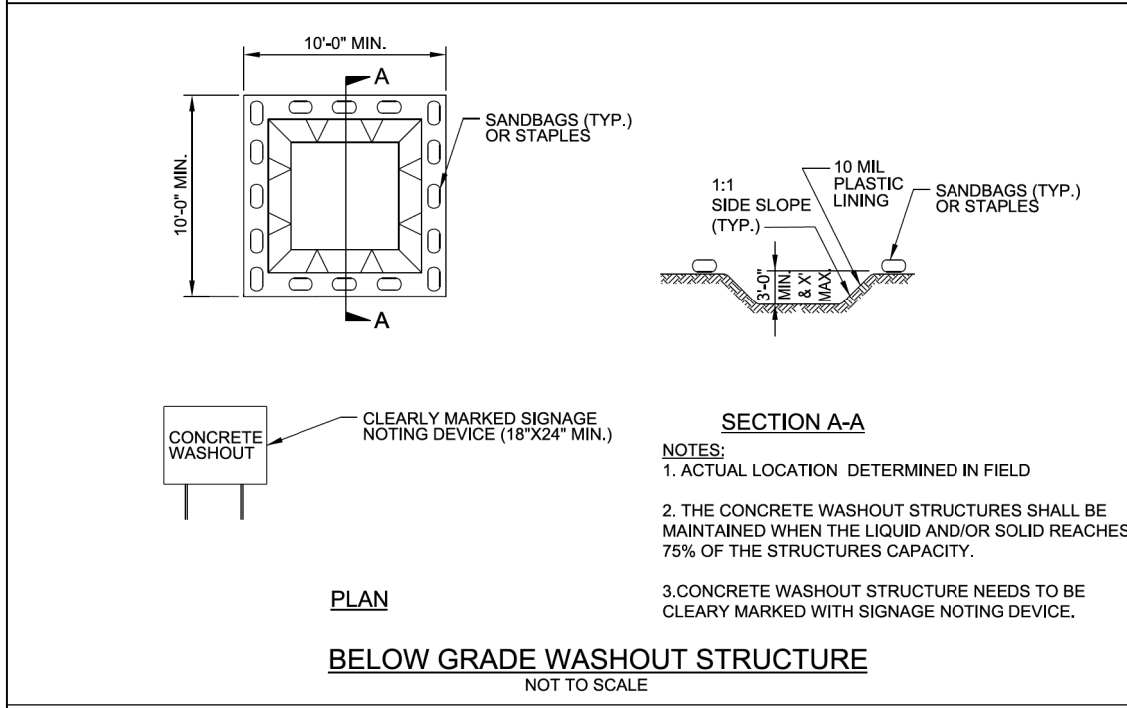

DIVISION OF HIGHWAYS
STATE OF NORTH CAROLINA

SOIL STABILIZATION TIMEFRAMES

<i>SITE DESCRIPTION</i>	<i>STABILIZATION TIME</i>	<i>TIMEFRAME EXCEPTIONS</i>
PERIMETER DIKES, SWALES, DITCHES AND SLOPES	7 DAYS	NONE
HIGH QUALITY WATER (HOW) ZONES	7 DAYS	NONE
SLOPES STEEPER THAN 3:1	7 DAYS	IF SLOPES ARE 10' OR LESS IN LENGTH AND ARE NOT STEEPER THAN 2:1, 14 DAYS ARE ALLOWED.
SLOPES 3:1 OR FLATTER	14 DAYS	7 DAYS FOR SLOPES GREATER THAN 50' IN LENGTH.
ALL OTHER AREAS WITH SLOPES FLATTER THAN 4:1	14 DAYS	NONE, EXCEPT FOR PERIMETERS AND HOW ZONES.

PROJECT NO.	SHEET NO.
44856.3.39	EC-4
F.A. PROJECT NO. HSIP-00610651	

CLEARING & GRUBBING PHASE

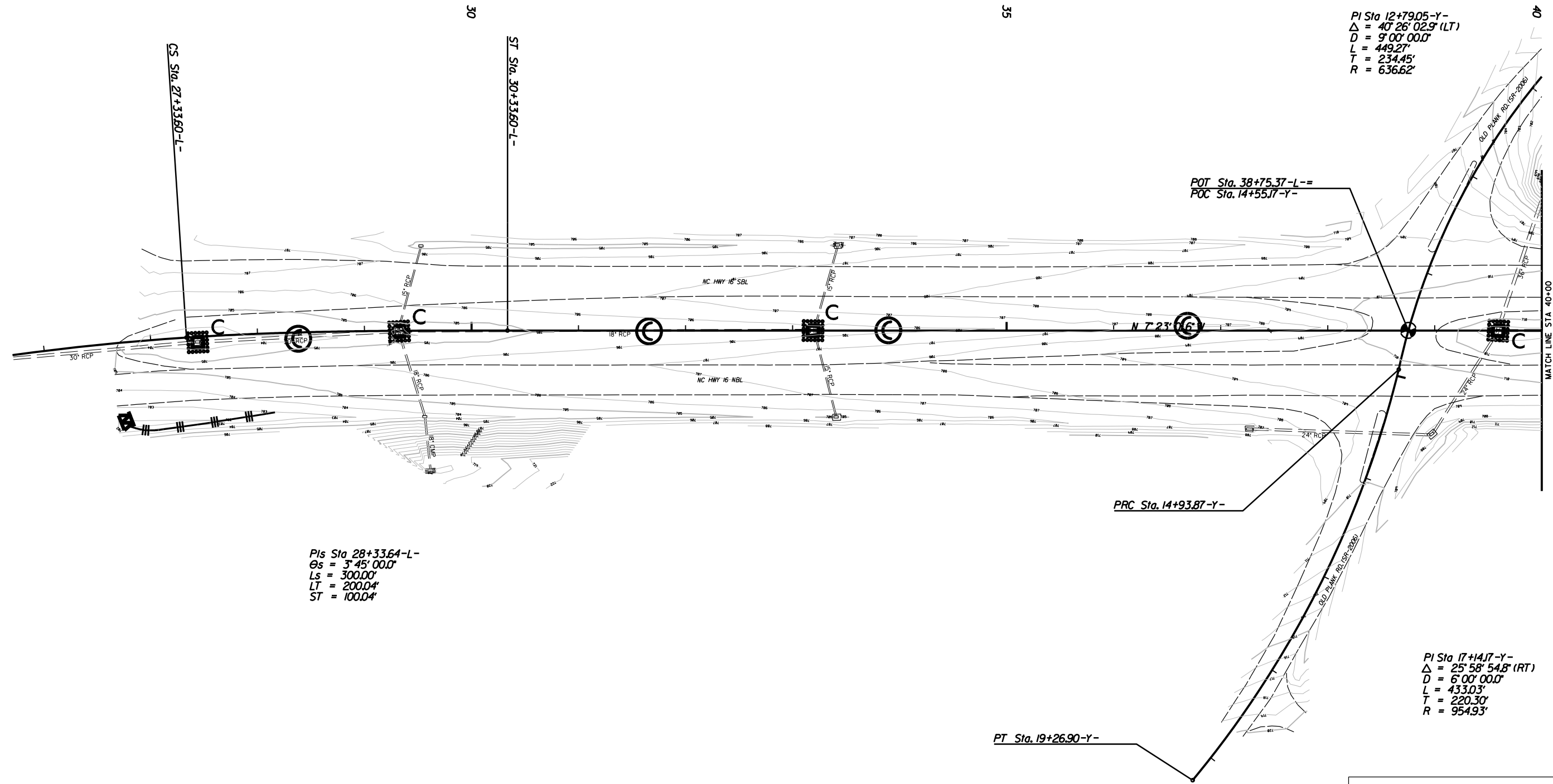

PIs Sta 28+33.64-L-
 $\Theta_s = 3^\circ 45' 00.0"$
 $L_s = 300.00'$
 $LT = 200.04'$
 $ST = 100.04'$

EROSION CONTROL MEASURES MAY BE CHANGED
 IN FIELD AS DIRECTED BY THE ENGINEER

SIGNALIZED R/C ON NC 16
 AT OLD PLANK ROAD (SR-2006) AND
 PLEASANT GROVE ROAD (SR-2008)

SCALE	1"=50'		REVISIONS
DATE	4-2022		
DWG. BY	JCB		
DESIGN BY	TBL		
APPROVED	JDH		

PROJECT NO.	SHEET NO.
44856.3.39	EC-4A
F.A. PROJECT NO. HSIP-00610651	

CONSTRUCTION PHASE

INSTALL MATTING FOR
EROSION CONTROL IN THE
PROPOSED DITCH LINE.
SEE SHEET 2A

37+00 TO 38+00 -L- MEDIAN
69+50 TO 71+50 -L- MEDIAN
78+00 TO 85+50 -L- MEDIAN

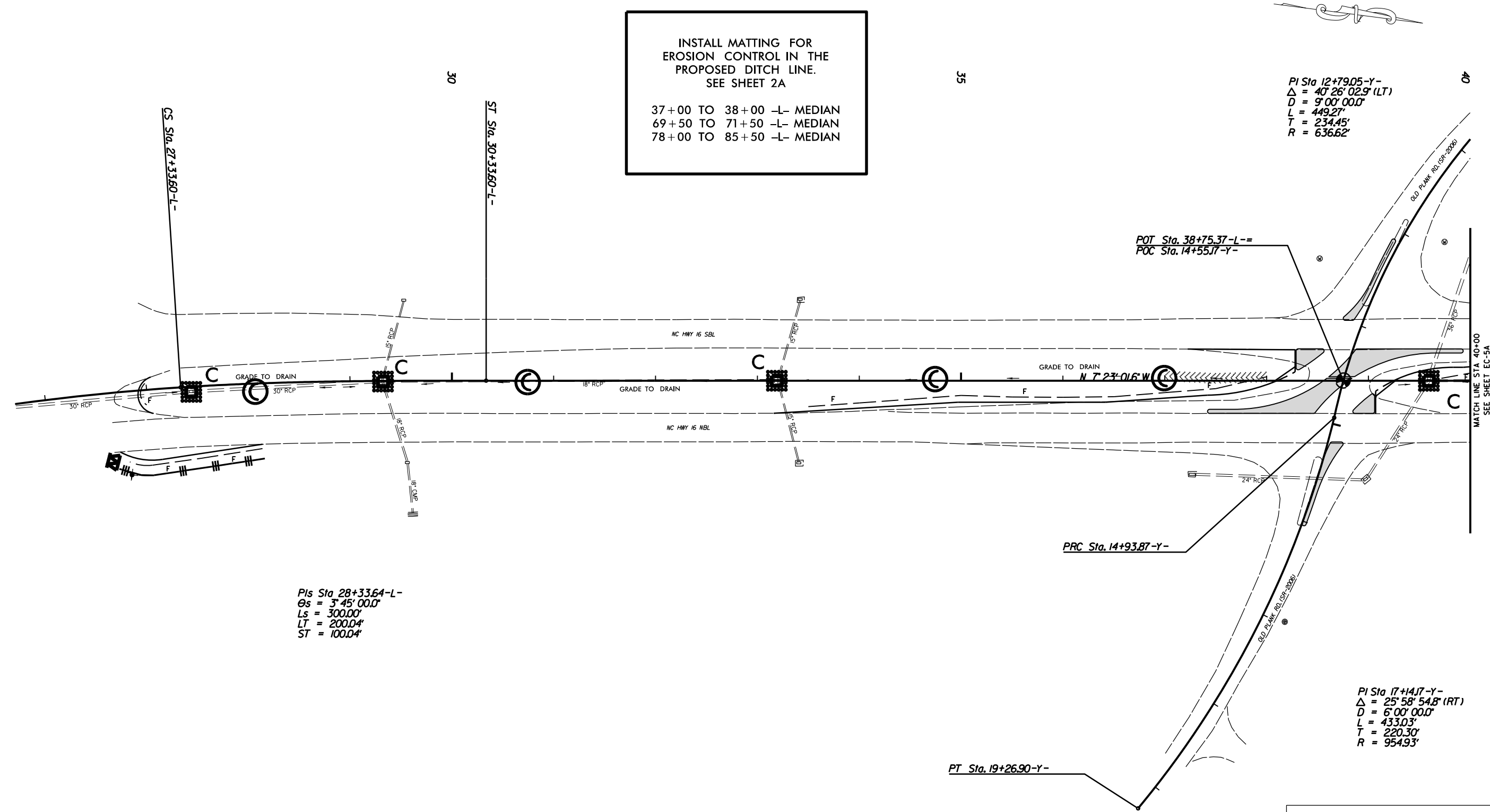

PI Sta 12+79.05-Y-
 $\Delta = 40^\circ 26' 02.9\"$ (LT)
 $D = 9' 00' 00.0\"$
 $L = 449.27'$
 $T = 234.45'$
 $R = 636.62'$

POT Sta. 38+75.37-L-=
 POC Sta. 14+55.17-Y-

PIs Sta 28+33.64-L-
 $\Theta_s = 3^\circ 45' 00.0\"$
 $L_s = 300.00'$
 $LT = 200.04'$
 $ST = 100.04'$

PRC Sta. 14+93.87-Y-

PI Sta 17+14.17-Y-
 $\Delta = 25^\circ 58' 54.8\"$ (RT)
 $D = 6' 00' 00.0\"$
 $L = 433.03'$
 $T = 220.30'$
 $R = 954.93'$

PT Sta. 19+26.90-Y-

MATCH LINE STA 40+00
SEE SHEET EC-5A

EROSION CONTROL MEASURES MAY BE CHANGED
IN FIELD AS DIRECTED BY THE ENGINEER

SIGNALIZED R/CION NC 16
AT OLD PLANK ROAD (SR-2006) AND
PLEASANT GROVE ROAD (SR-2008)

SCALE	1"=50'		REVISIONS
DATE	4-2022		
DWG. BY	JCB		
DESIGN BY	TBL		
APPROVED	JDH		

PROJECT NO.	SHEET NO.
44856.3.39	EC-5
F.A. PROJECT NO. HSIP-00610651	

CLEARING & GRUBBING PHASE

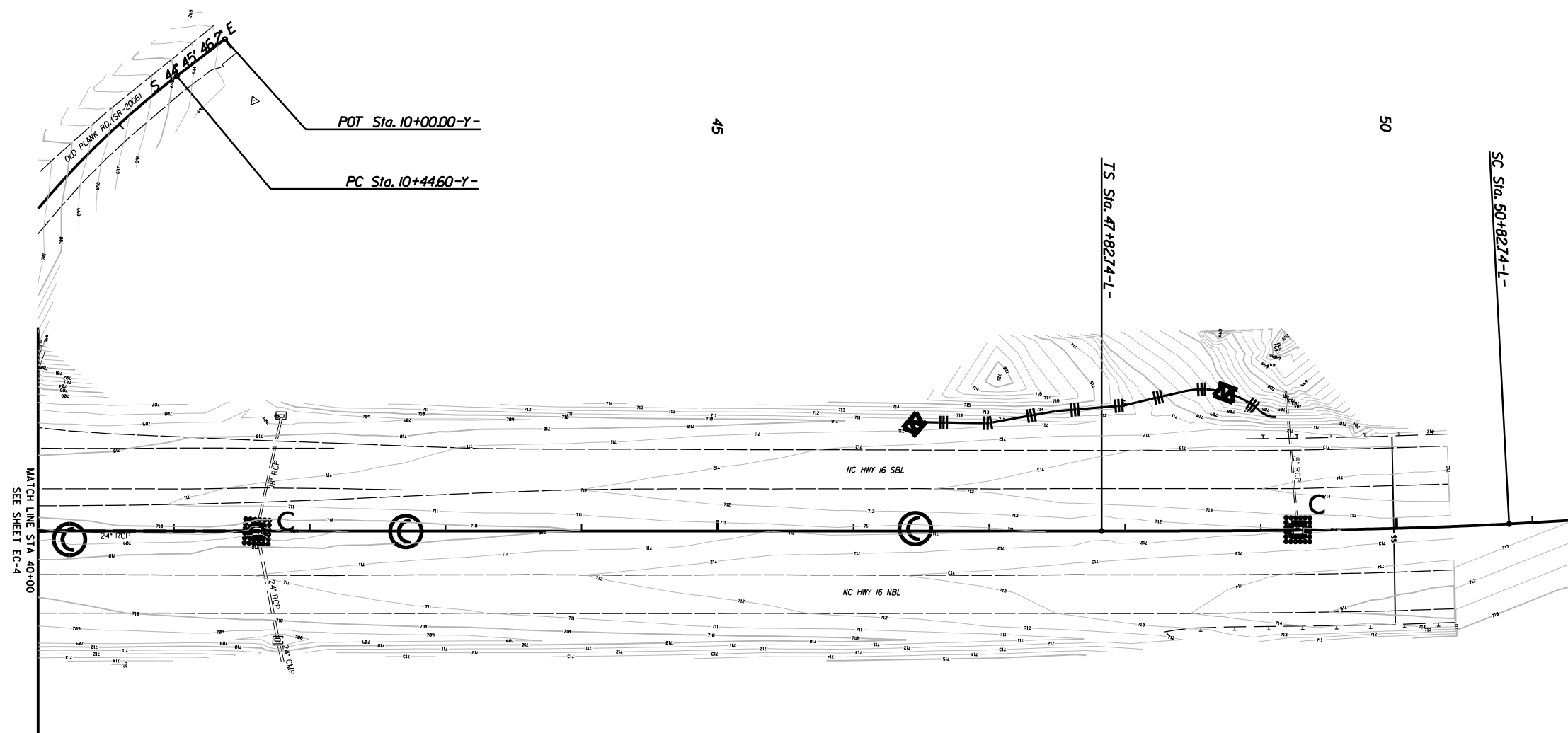

Pls Sta 49+82.77-L-
 $\Theta_s = 3^{\circ}00'00''$
 $L_s = 300.00'$
 $LT = 200.03'$
 $ST = 100.03'$

EROSION CONTROL MEASURES MAY BE CHANGED
IN FIELD AS DIRECTED BY THE ENGINEER

SIGNALIZED R/C ON NC 16
AT OLD PLANK ROAD (SR-2006) AND
PLEASANT GROVE ROAD (SR-2008)

SCALE	1"=50'
DATE	4-2022
DWG. BY	JCB
DESIGN BY	TBL
APPROVED	JDH



REVISIONS	

PROJECT NO.	SHEET NO.
44856.3.39	EC-5A
F.A. PROJECT NO. HSIP-00610651	

CONSTRUCTION PHASE

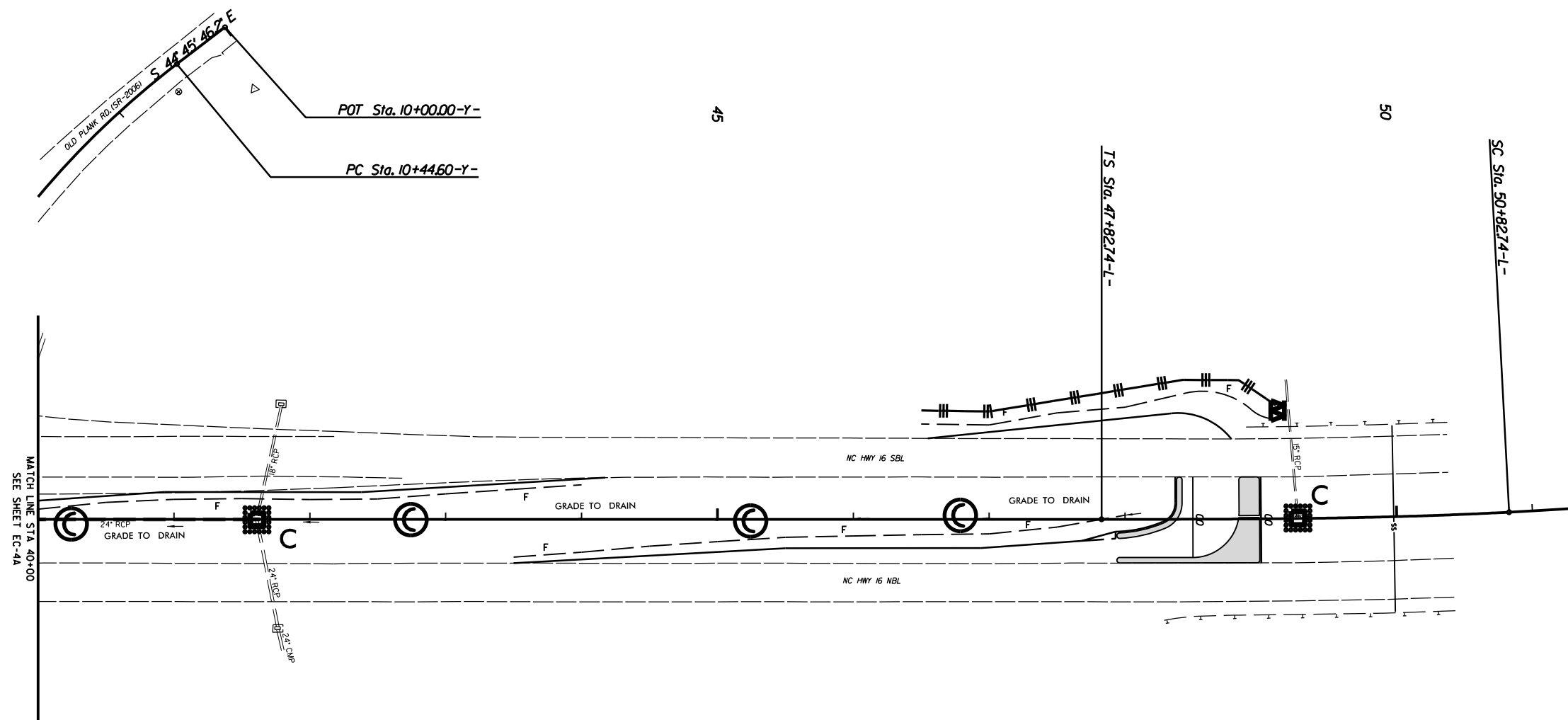

INSTALL MATTING FOR
EROSION CONTROL IN THE
PROPOSED DITCH LINE.
SEE SHEET 2A

37+00 TO 38+00 -L- MEDIAN
69+50 TO 71+50 -L- MEDIAN
78+00 TO 85+50 -L- MEDIAN

Pls Sta 49+82.77-L-
 $\theta_s = 3'00''00''$
 $L_s = 300.00'$
 $LT = 200.03'$
 $ST = 100.03'$

EROSION CONTROL MEASURES MAY BE CHANGED
IN FIELD AS DIRECTED BY THE ENGINEER

SIGNALIZED R/C ON NC 16
AT OLD PLANK ROAD (SR-2006) AND
PLEASANT GROVE ROAD (SR-2008)

SCALE	r=50'		REVISIONS
DATE	4-2022		
DWG. BY	JCB		
DESIGN BY	TLB		
APPROVED	JDH		

CLEARING & GRUBBING PHASE

PROJECT NO.	SHEET NO.
44856.3.39	EC-6
F.A. PROJECT NO. HSIP-00610651	

PI Sta 11+04.70-YI-
 $\Delta = 3^{\circ} 22' 43.2" (LT)$
 $D = 1^{\circ} 36' 50.3"$
 $L = 209.34'$
 $T = 104.70'$
 $R = 3,550.00'$

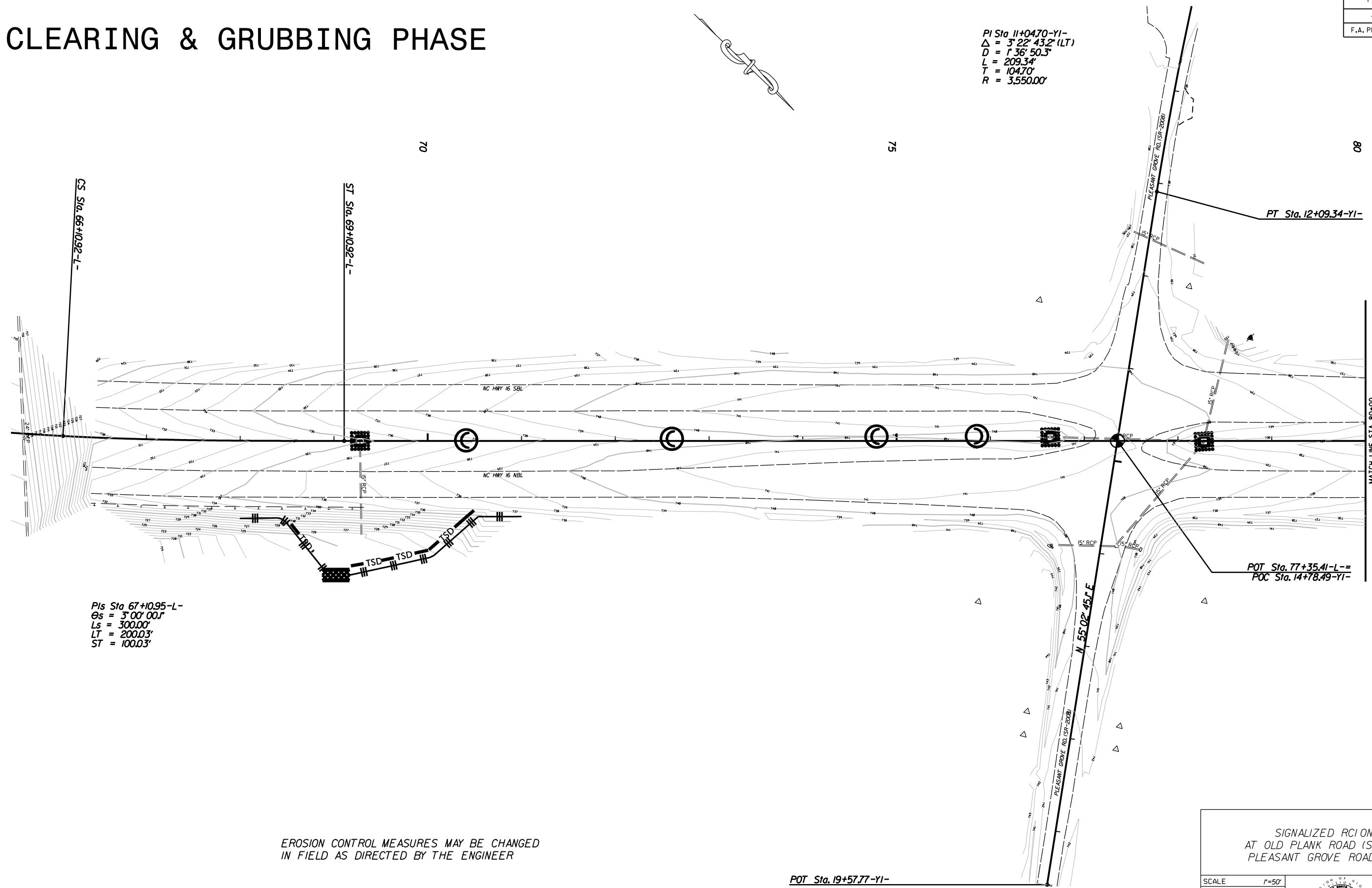

PIs Sta 67+10.95-L-
 $\Theta_s = 3^{\circ} 00' 00"$
 $L_s = 300.00'$
 $LT = 200.03'$
 $ST = 100.03'$

EROSION CONTROL MEASURES MAY BE CHANGED IN FIELD AS DIRECTED BY THE ENGINEER

POT Sta. 19+57.77-YI-

SIGNALIZED ROUNDABOUT ON NC 16 AT OLD PLANK ROAD (SR-2006) AND PLEASANT GROVE ROAD (SR-2008)

SCALE	1"=50'
DATE	4-2022
DWG. BY	JCB
DESIGN BY	TBL
APPROVED	JDH



REVISIONS	

MATCH LINE STA 80+00 SEE SHEET EC-7

CONSTRUCTION PHASE

PROJECT NO.	SHEET NO.
44856.3.39	EC-6A
F.A. PROJECT NO. HSIP-00610651	

PI Sta 11+04.70-Y1-
 $\Delta = 3^\circ 22' 43.2''$ (LT)
 $D = 136' 50.3''$
 $L = 209.34'$
 $T = 104.70'$
 $R = 3550.00'$

INSTALL MATTING FOR
 EROSION CONTROL IN THE
 PROPOSED DITCH LINE.
 SEE SHEET 2A

 37+00 TO 38+00 -L- MEDIAN
 69+50 TO 71+50 -L- MEDIAN
 78+00 TO 85+50 -L- MEDIAN

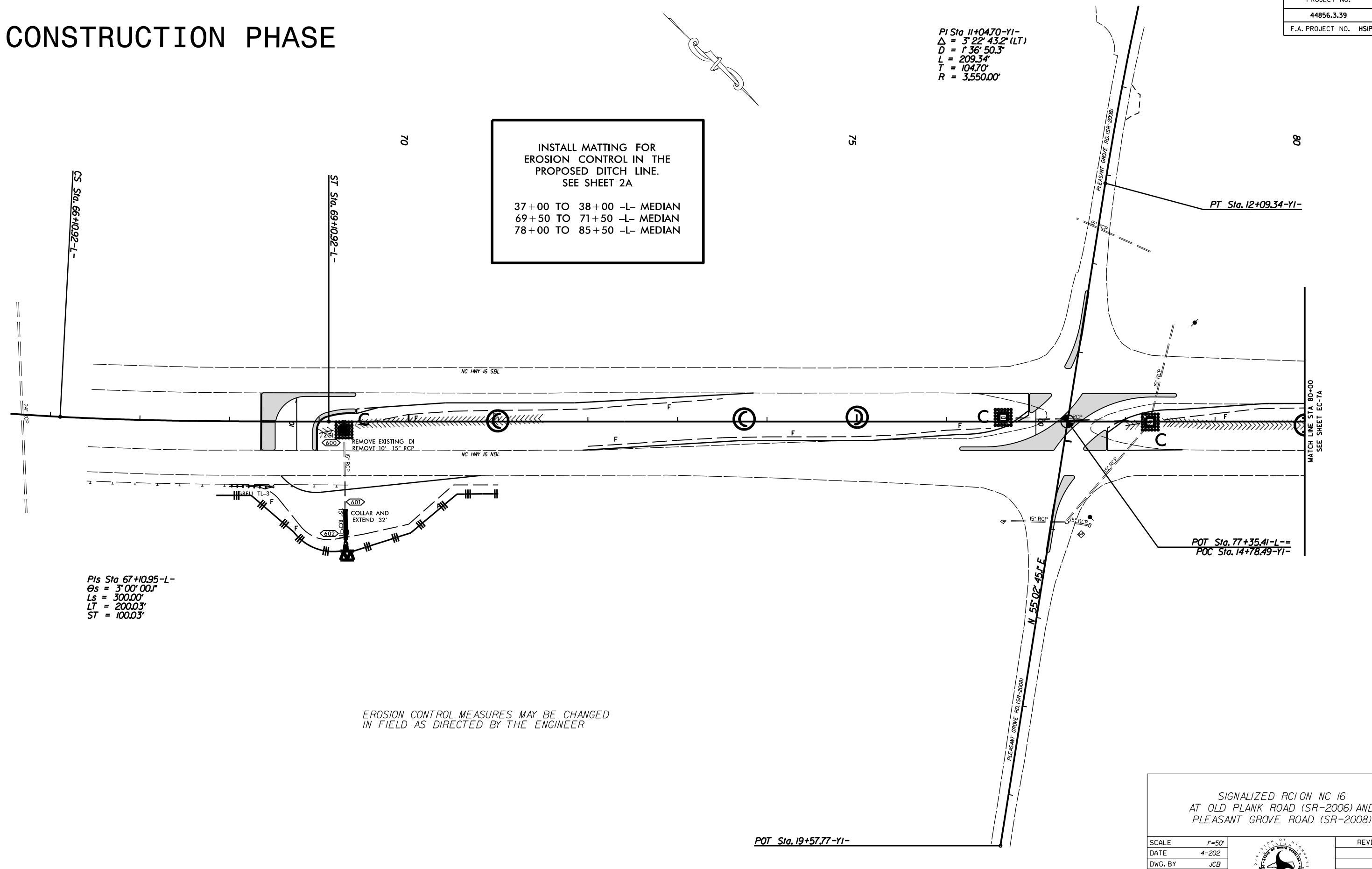

PIs Sta 67+10.95-L-
 $\theta_s = 3^\circ 00' 00''$
 $L_s = 300.00'$
 $LT = 200.03'$
 $ST = 100.03'$

EROSION CONTROL MEASURES MAY BE CHANGED
 IN FIELD AS DIRECTED BY THE ENGINEER

SIGNALIZED RCI ON NC 16
 AT OLD PLANK ROAD (SR-2006) AND
 PLEASANT GROVE ROAD (SR-2008)

SCALE	1"=50'		REVISIONS
DATE	4-202		
DWG. BY	JCB		
DESIGN BY	TBL		
APPROVED	JDH		

POT Sta. 19+57.77-Y1-

CLEARING & GRUBBING PHASE

PROJECT NO.	SHEET NO.
44856.3.39	EC-7
F.A. PROJECT NO. HSIP-00610651	

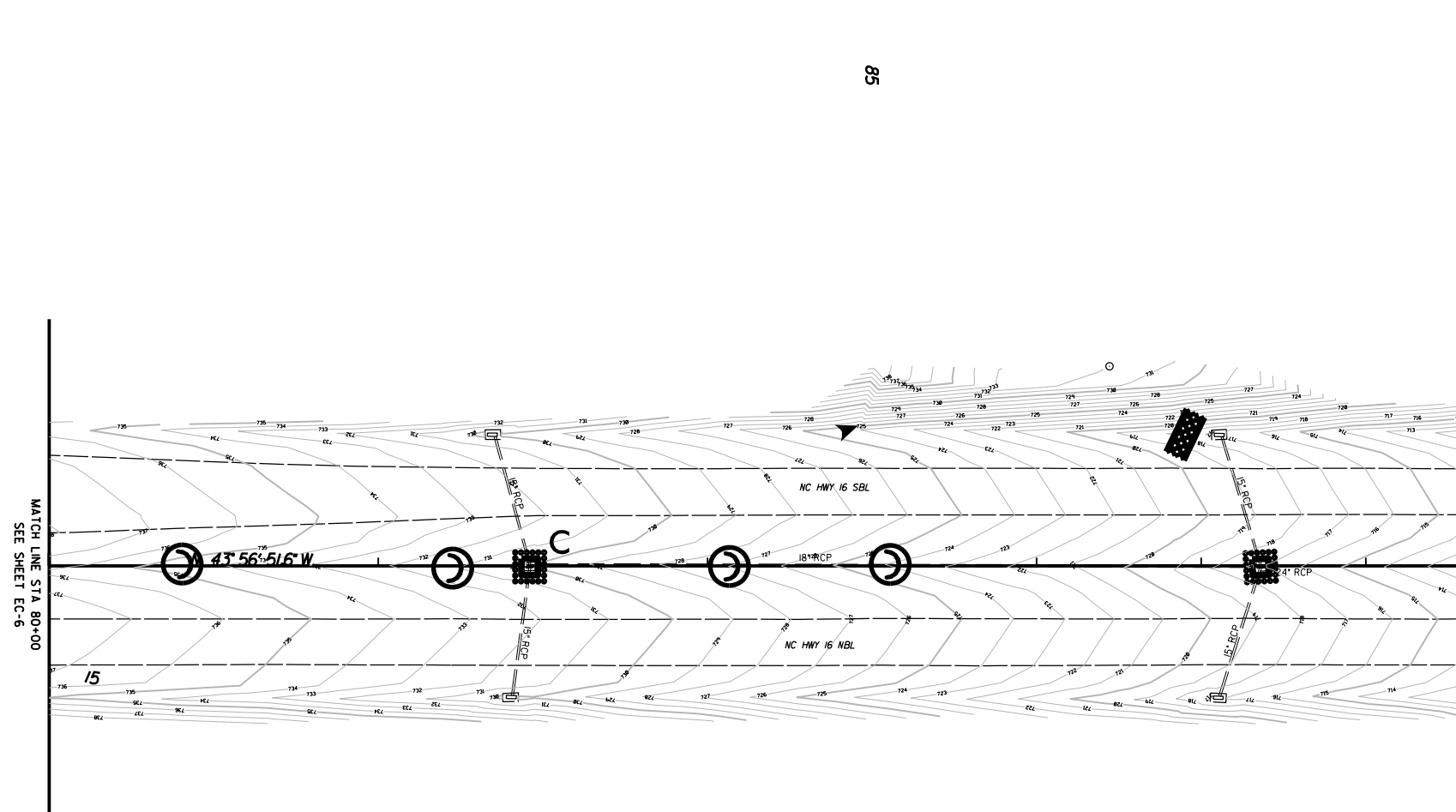

EROSION CONTROL MEASURES MAY BE CHANGED
IN FIELD AS DIRECTED BY THE ENGINEER

SIGNALIZED ROUNDABOUT ON NC 16
AT OLD PLANK ROAD (SR-2006) AND
PLEASANT GROVE ROAD (SR-2008)

SCALE	1"=50'
DATE	4-2022
DWG. BY	JCB
DESIGN BY	TLB
APPROVED	JDH



REVISIONS	

CONSTRUCTION PHASE

PROJECT NO.	SHEET NO.
44856.3.39	EC-7A
F.A. PROJECT NO. HSIP-00610651	

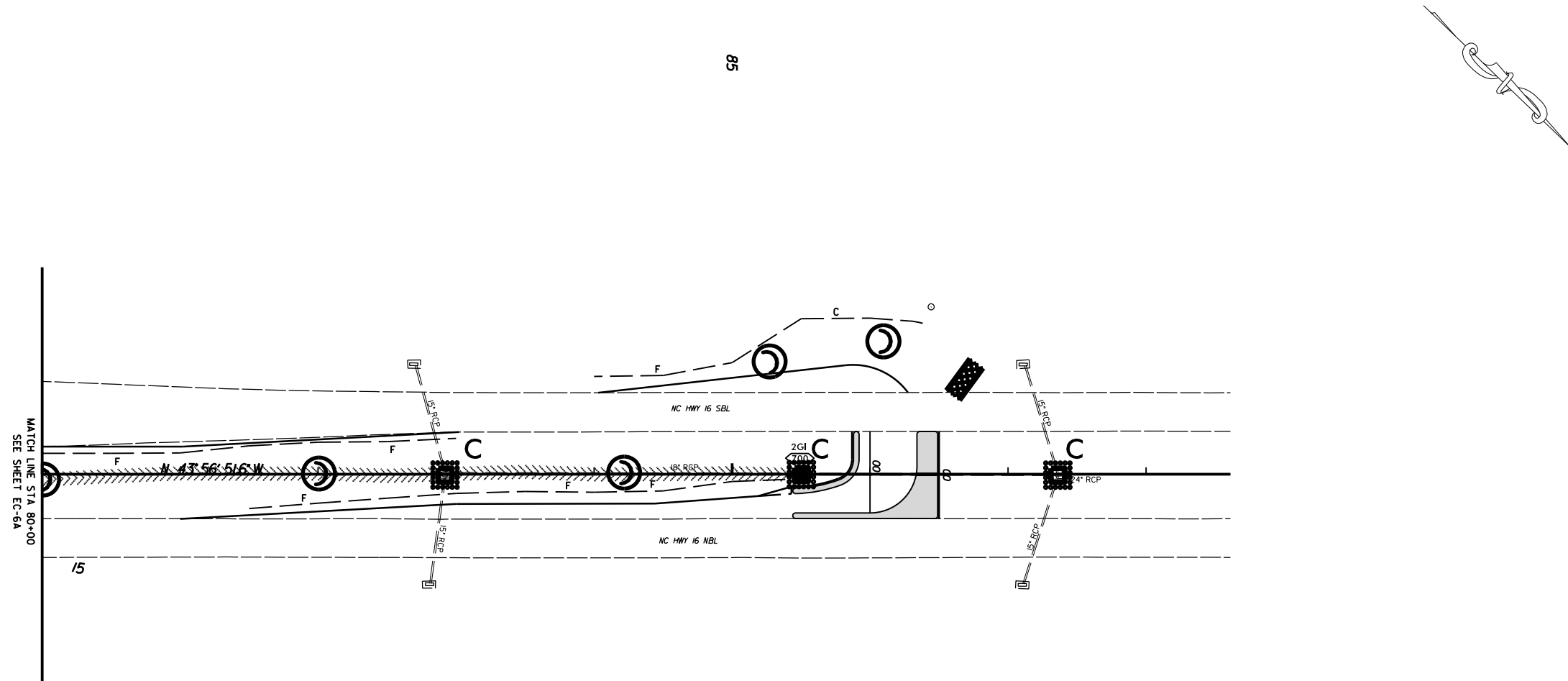

INSTALL MATTING FOR
EROSION CONTROL IN THE
PROPOSED DITCH LINE.
SEE SHEET 2A

37+00 TO 38+00 -L- MEDIAN
69+50 TO 71+50 -L- MEDIAN
78+00 TO 85+50 -L- MEDIAN

EROSION CONTROL MEASURES MAY BE CHANGED
IN FIELD AS DIRECTED BY THE ENGINEER

SIGNALIZED RCI ON NC 16
AT OLD PLANK ROAD (SR-2006) AND
PLEASANT GROVE ROAD (SR-2008)

SCALE	1"=50'		REVISIONS
DATE	4-2022		
DWG. BY	JCB		
DESIGN BY	TBL		
APPROVED	JDH		

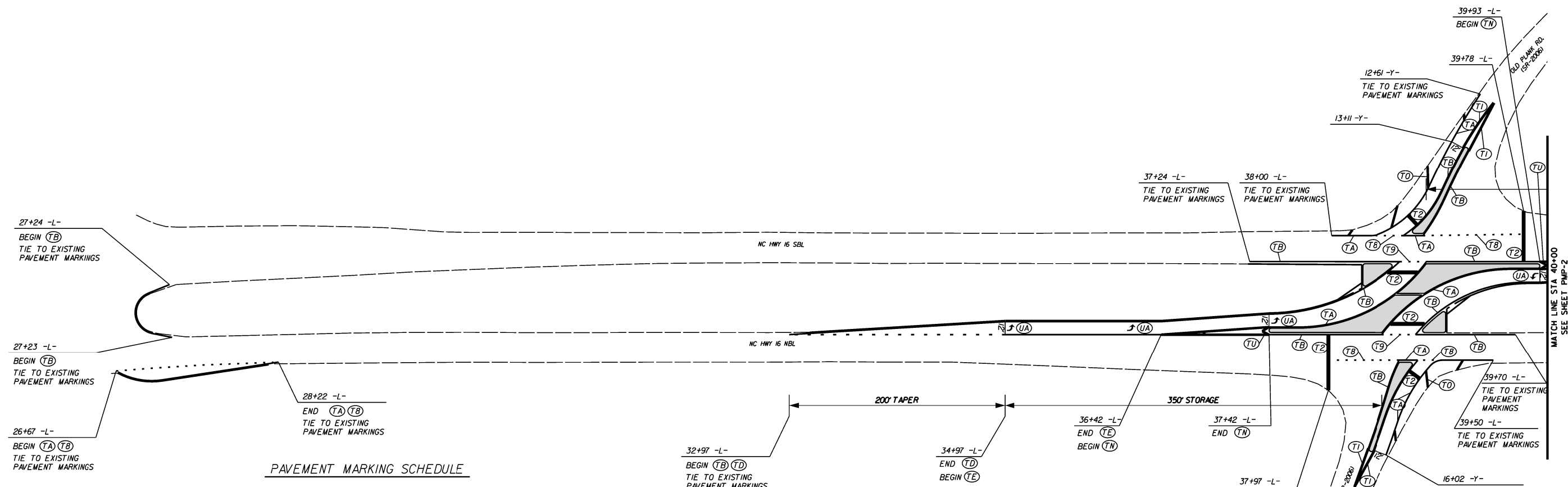
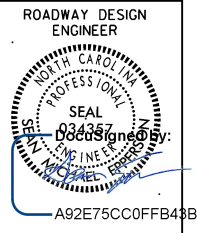

PAVEMENT MARKING SCHEDULE

27+24 -L-
BEGIN (TB)
TIE TO EXISTING
PAVEMENT MARKINGS

27+23 -L-
BEGIN (TB)
TIE TO EXISTING
PAVEMENT MARKINGS

26+67 -L-
BEGIN (TA) (TB)
TIE TO EXISTING
PAVEMENT MARKINGS

28+22 -L-
END (TA) (TB)
TIE TO EXISTING
PAVEMENT MARKINGS

32+97 -L-
BEGIN (TB) (TD)
TIE TO EXISTING
PAVEMENT MARKINGS

34+97 -L-
END (TD)
BEGIN (TE)

36+42 -L-
END (TE)
BEGIN (TN)

37+42 -L-
END (TN)

37+97 -L-

39+70 -L-
TIE TO EXISTING
PAVEMENT MARKINGS

39+50 -L-
TIE TO EXISTING
PAVEMENT MARKINGS

16+02 -Y-
TIE TO EXISTING
PAVEMENT MARKINGS

16+40 -Y-
TIE TO EXISTING
PAVEMENT MARKINGS

THERMOPLASTIC MARKING LINES

- | | |
|---|--|
| TA - WHITE EDGELINE (4',.90 MIL) | TU - WHITE DIAGONAL (12',.90 MIL) |
| TB - YELLOW EDGELINE (4',.90 MIL) | TV - YELLOW DIAGONAL (12',.90 MIL) |
| TC - 10FT. WHITE SKIP (4',.90 MIL) | TI - WHITE LINE, RR X (16',.90 MIL) |
| TD - 3FT.-9FT./SP WHITE MINISKIP (4',.90 MIL) | T2 - WHITE STOPBAR (24',.90 MIL) |
| TE - WHITE SOLID LANE LINE (4',.90 MIL) | T3 - WHITE CROSSWALK LINE (24',.90 MIL) |
| TF - 10FT. YELLOW SKIP (4',.90 MIL) | T4 - WHITE RUMBLE STRIP (4",.240 MIL) |
| TH - YELLOW SINGLE CENTER (4',.90 MIL) | T5 - YELLOW RUMBLE STRIP (4",.240 MIL) |
| TI - YELLOW DOUBLE CENTER (4',.90 MIL) | T6 - WHITE EDGELINE (6',.90 MIL) |
| TJ - 10FT. WHITE SKIP (6',.90 MIL) | T7 - YELLOW EDGELINE (6',.90 MIL) |
| TK - 3FT.-9FT./SP WHITE MINISKIP (6',.90 MIL) | T8 - 2FT.-6FT./SP WHITE MINISKIP (4',.90 MIL) |
| TL - WHITE SOLID LANE LINE (6',.90 MIL) | T9 - 2FT.-6FT./SP YELLOW MINISKIP (4',.90 MIL) |
| TM - 10FT. YELLOW SKIP (6',.90 MIL) | T10 - 3FT.-3FT./SP WHITE MINISKIP (12',.90 MIL) |
| TN - WHITE GORELINE (8',.90 MIL) | T11 - 2FT.-6FT./SP WHITE MINISKIP (6',.90 MIL) |
| TO - WHITE DIAGONAL (8',.90 MIL) | T12 - 2FT.-6FT./SP YELLOW MINISKIP (6',.90 MIL) |
| TP - YELLOW DIAGONAL (8',.90 MIL) | T13 - 3FT.-9FT./SP WHITE MINISKIP (8',.90 MIL) |
| TQ - WHITE CROSSWALK LINE (8',.90 MIL) | T14 - 3FT.-9FT./SP WHITE MINISKIP (12',.90 MIL) |
| TR - WHITE SOLID LANE LINE (8',.90 MIL) | T15 - YELLOW SINGLE CENTER (6',.90 MIL) |
| TS - WHITE GORELINE (12',.90 MIL) | T16 - YELLOW DOUBLE CENTER (6',.90 MIL) |
| TT - WHITE SOLID LANE LINE (12',.90 MIL) | T17 - 3FT.-3FT./SP WHITE MINISKIP ENTRANCE LINE (8',.90 MIL) |

THERMOPLASTIC MARKING SYMBOLS

- | | |
|--|--|
| UA - LEFT TURN ARROW (90 MIL) | UU - FISH-HOOK STRAIGHT ARROW (90 MIL) |
| UB - RIGHT TURN ARROW (90 MIL) | UV - FISH-HOOK LEFT/STRAIGHT ARROW (90 MIL) |
| UC - STRAIGHT ARROW (90 MIL) | UW - FISH-HOOK RIGHT/STRAIGHT ARROW (90 MIL) |
| UD - COMBO. LEFT/STRAIGHT ARROW (90 MIL) | UX - FISH-HOOK LEFT/RIGHT ARROW (90 MIL) |
| UE - COMBO. RIGHT/STRAIGHT ARROW (90 MIL) | UY - FISH-HOOK LEFT/RIGHT/STRAIGHT ARROW (90 MIL) |
| UF - COMBO. LEFT/RIGHT ARROW (90 MIL) | UZ - FISH-HOOK W/CIRCLE STRAIGHT ARROW (90 MIL) |
| UG - COMBO. LEFT/RIGHT/STRAIGHT ARROW (90 MIL) | |
| UH - HANDICAP PARKING (90 MIL) | YA - FISH-HOOK W/CIRCLE LEFT ARROW (90 MIL) |
| UI - ALPHANUMERIC CHAR. (90 MIL) | YB - FISH-HOOK W/CIRCLE LEFT/STRAIGHT ARROW (90 MIL) |
| UJ - BICYCLE SYMBOL (90 MIL) | YC - FISH-HOOK W/CIRCLE LEFT/RIGHT/STRAIGHT ARROW (90 MIL) |
| UK - BICYCLE STRAIGHT ARROW (90 MIL) | YD - COMBO. LEFT/U-TURN ARROW (90 MIL) |
| UL - BICYCLE CHAR. (90 MIL) | MA - PERMANENT RAISED MARKER (YELLOW & YELLOW) |
| UM - 12" YIELD LINE TRIANGLE (90 MIL) | MB - PERMANENT RAISED MARKER (CRYSTAL & RED) |
| UN - 24" YIELD LINE TRIANGLE (90 MIL) | MC - PERMANENT RAISED MARKER (YELLOW & RED) |
| UO - BICYCLE LEFT ARROW (90 MIL) | MD - PERMANENT RAISED MARKER (YELLOW) |
| UP - MERGE ARROW (90 MIL) | ME - SNOWFLOWABLE MARKER (YELLOW & YELLOW) |
| UQ - RAMP ARROW SYMBOL (90 MIL) | MF - SNOWFLOWABLE MARKER (CRYSTAL & RED) |
| UR - SHARROW (90 MIL) | MG - SNOWFLOWABLE MARKER (YELLOW & RED) |
| US - BICYCLE LOOP DETECTOR (90 MIL) | ML - PERMANENT RAISED MARKER (CRYSTAL & CRYSTAL) |
| UT - U-TURN ARROW (90 MIL) | MO - SNOWFLOWABLE MARKER (CRYSTAL & CRYSTAL) |

SIGNALIZED RCI ON NC 16
AT OLD PLANK RD. (SR-2006) AND
PLEASANT GROVE RD. (SR-2008)

SCALE	1"=50'		REVISIONS
DATE	3-2022		
DWG. BY	TBL		
DESIGN BY	TBL		
APPROVED	JDH		

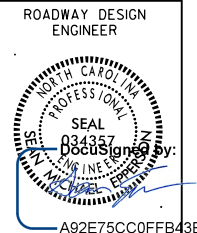

PAVEMENT MARKING SCHEDULE

THERMOPLASTIC MARKING LINES

- | | |
|---|--|
| TA - WHITE EDGELINE (4".90 MIL) | TU - WHITE DIAGONAL (12".90 MIL) |
| TB - YELLOW EDGELINE (4".90 MIL) | TV - YELLOW DIAGONAL (12".90 MIL) |
| TC - 10FT. WHITE SKIP (4".90 MIL) | TI - WHITE LINE, RR X (16".90 MIL) |
| TD - 3FT.-9FT./SP WHITE MINISKIP (4".90 MIL) | T2 - WHITE STOPBAR (24".90 MIL) |
| TE - WHITE SOLID LANE LINE (4".90 MIL) | T3 - WHITE CROSSWALK LINE (24".90 MIL) |
| TF - 10FT. YELLOW SKIP (4".90 MIL) | T4 - WHITE RUMBLE STRIP (4".240 MIL) |
| TH - YELLOW SINGLE CENTER (4".90 MIL) | T5 - YELLOW RUMBLE STRIP (4".240 MIL) |
| TI - YELLOW DOUBLE CENTER (4".90 MIL) | T6 - WHITE EDGELINE (16".90 MIL) |
| TJ - 10FT. WHITE SKIP (16".90 MIL) | T7 - YELLOW EDGELINE (16".90 MIL) |
| TK - 3FT.-9FT./SP WHITE MINISKIP (16".90 MIL) | T8 - 2FT.-6FT./SP WHITE MINISKIP (4".90 MIL) |
| TL - WHITE SOLID LANE LINE (16".90 MIL) | T9 - 2FT.-6FT./SP YELLOW MINISKIP (4".90 MIL) |
| TM - 10FT. YELLOW SKIP (16".90 MIL) | T10 - 3FT.-3FT./SP WHITE MINISKIP (12".90 MIL) |
| TN - WHITE GORELINE (8".90 MIL) | T11 - 2FT.-6FT./SP WHITE MINISKIP (16".90 MIL) |
| TO - WHITE DIAGONAL (8".90 MIL) | T12 - 2FT.-6FT./SP YELLOW MINISKIP (16".90 MIL) |
| TP - YELLOW DIAGONAL (8".90 MIL) | T13 - 3FT.-9FT./SP WHITE MINISKIP (18".90 MIL) |
| TQ - WHITE CROSSWALK LINE (8".90 MIL) | T14 - 3FT.-9FT./SP WHITE MINISKIP (12".90 MIL) |
| TR - WHITE SOLID LANE LINE (18".90 MIL) | T15 - YELLOW SINGLE CENTER (16".90 MIL) |
| TS - WHITE GORELINE (12".90 MIL) | T16 - YELLOW DOUBLE CENTER (16".90 MIL) |
| TT - WHITE SOLID LANE LINE (12".90 MIL) | T17 - 3FT.-3FT./SP WHITE MINISKIP ENTRANCE LINE (18".90 MIL) |

THERMOPLASTIC MARKING SYMBOLS

- | | |
|--|--|
| UA - LEFT TURN ARROW (90 MIL) | UU - FISH-HOOK STRAIGHT ARROW (90 MIL) |
| UB - RIGHT TURN ARROW (90 MIL) | UV - FISH-HOOK LEFT/STRAIGHT ARROW (90 MIL) |
| UC - STRAIGHT ARROW (90 MIL) | UW - FISH-HOOK RIGHT/STRAIGHT ARROW (90 MIL) |
| UD - COMBO. LEFT/STRAIGHT ARROW (90 MIL) | UX - FISH-HOOK LEFT/RIGHT ARROW (90 MIL) |
| UE - COMBO. RIGHT/STRAIGHT ARROW (90 MIL) | UY - FISH-HOOK LEFT/RIGHT/STRAIGHT ARROW (90 MIL) |
| UF - COMBO. LEFT/RIGHT ARROW (90 MIL) | UZ - FISH-HOOK W/CIRCLE STRAIGHT ARROW (90 MIL) |
| UG - COMBO. LEFT/RIGHT/STRAIGHT ARROW (90 MIL) | YA - FISH-HOOK W/CIRCLE LEFT ARROW (90 MIL) |
| UH - HANDICAP PARKING (90 MIL) | YB - FISH-HOOK W/CIRCLE LEFT/STRAIGHT ARROW (90 MIL) |
| UI - ALPHANUMERIC CHAR. (90 MIL) | YC - FISH-HOOK W/CIRCLE LEFT/RIGHT/STRAIGHT ARROW (90 MIL) |
| UJ - BICYCLE SYMBOL (90 MIL) | YD - COMBO. LEFT/U-TURN ARROW (90 MIL) |
| UK - BICYCLE STRAIGHT ARROW (90 MIL) | MA - PERMANENT RAISED MARKER (YELLOW & YELLOW) |
| UL - BICYCLE CHAR. (90 MIL) | MB - PERMANENT RAISED MARKER (CRYSTAL & RED) |
| UM - 12" YIELD LINE TRIANGLE (90 MIL) | MC - PERMANENT RAISED MARKER (YELLOW & RED) |
| UN - 24" YIELD LINE TRIANGLE (90 MIL) | MD - PERMANENT RAISED MARKER (YELLOW) |
| UO - BICYCLE LEFT ARROW (90 MIL) | ME - SNOWPLOWABLE MARKER (YELLOW & YELLOW) |
| UP - MERGE ARROW (90 MIL) | MF - SNOWPLOWABLE MARKER (CRYSTAL & RED) |
| UQ - RAMP ARROW SYMBOL (90 MIL) | MG - SNOWPLOWABLE MARKER (YELLOW & RED) |
| UR - SHARROW (90 MIL) | ML - PERMANENT RAISED MARKER (CRYSTAL & CRYSTAL) |
| US - BICYCLE LOOP DETECTOR (90 MIL) | MO - SNOWPLOWABLE MARKER (CRYSTAL & CRYSTAL) |
| UT - U-TURN ARROW (90 MIL) | |

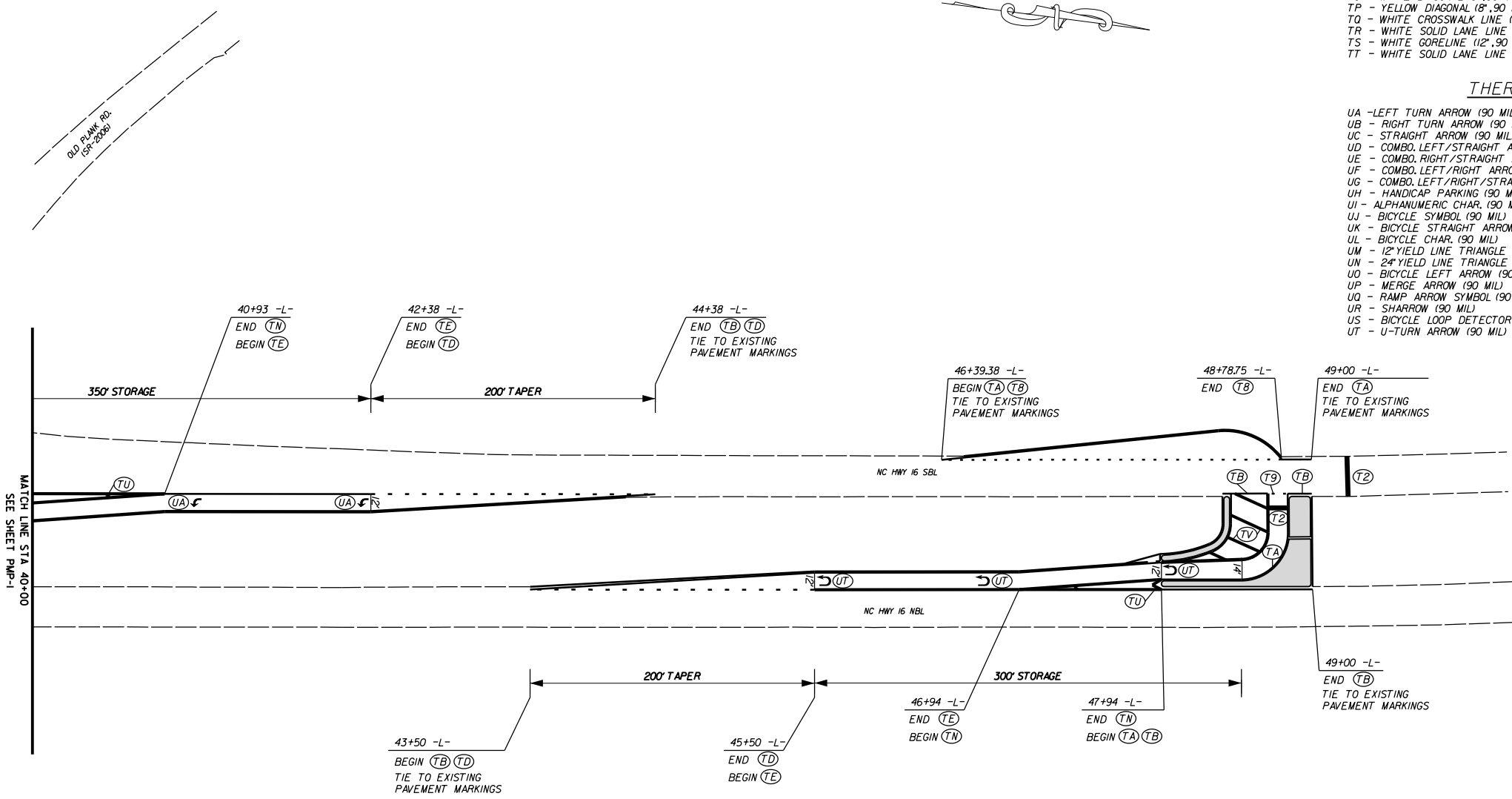

SIGNALIZED RCI ON NC 16
AT OLD PLANK RD.(SR-2006) AND
PLEASANT GROVE RD.(SR-2008)

SCALE	1"=50'		REVISIONS
DATE	3-2022		
DWG. BY	TBL		
DESIGN BY	TBL		
APPROVED	JDH		

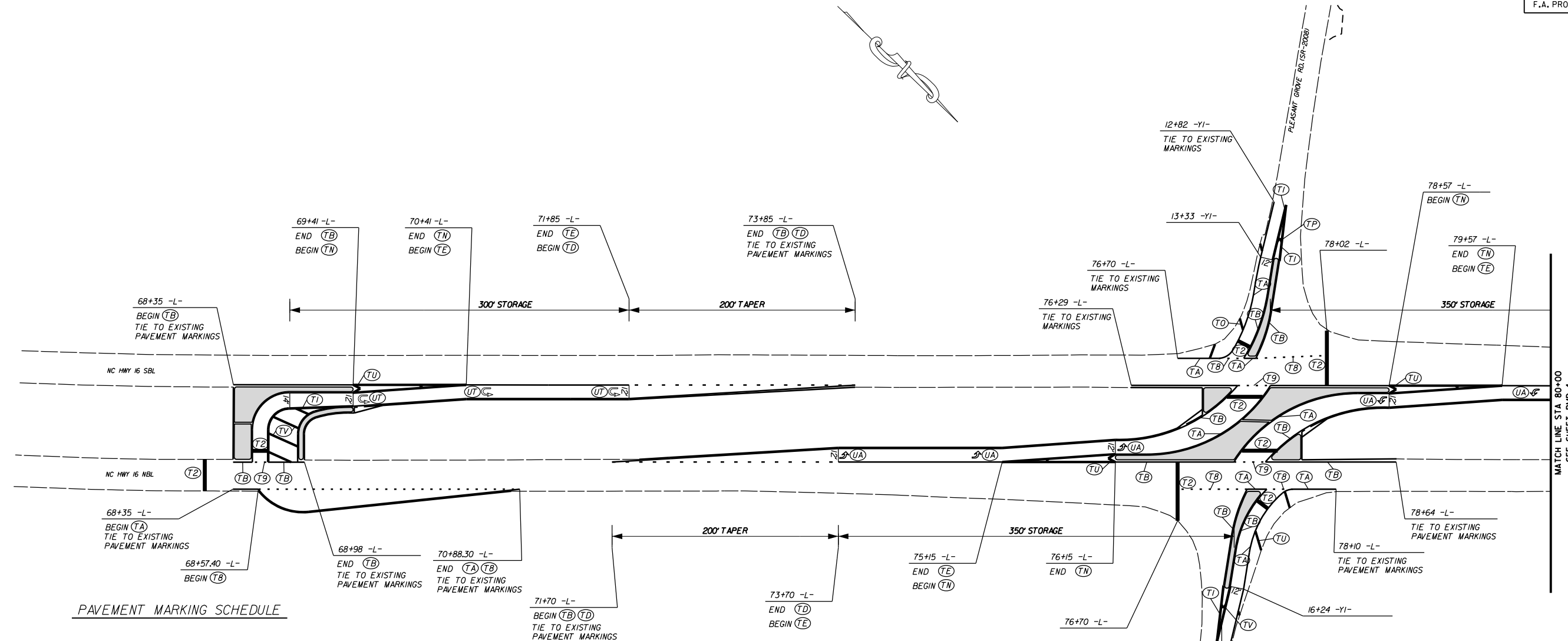
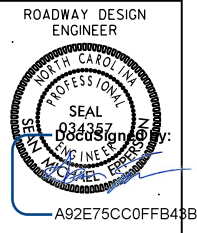

PAVEMENT MARKING SCHEDULE

THERMOPLASTIC MARKING LINES

- | | |
|---|---|
| TA - WHITE EDGELINE (4',.90 MIL) | TU - WHITE DIAGONAL (12',.90 MIL) |
| TB - YELLOW EDGELINE (4',.90 MIL) | TV - YELLOW DIAGONAL (12',.90 MIL) |
| TC - 10FT. WHITE SKIP (4',.90 MIL) | TI - WHITE LINE, RR X (16',.90 MIL) |
| TD - 3FT.-9FT./SP WHITE MINISKIP (4',.90 MIL) | T2 - WHITE STOPBAR (24',.90 MIL) |
| TE - WHITE SOLID LANE LINE (4',.90 MIL) | T3 - WHITE CROSSWALK LINE (24',.90 MIL) |
| TF - 10FT. YELLOW SKIP (4',.90 MIL) | T4 - WHITE RUMBLE STRIP (4',.240 MIL) |
| TH - YELLOW SINGLE CENTER (4',.90 MIL) | T5 - YELLOW RUMBLE STRIP (4',.240 MIL) |
| TJ - YELLOW DOUBLE CENTER (4',.90 MIL) | T6 - WHITE EDGELINE (16',.90 MIL) |
| TK - 10FT. WHITE SKIP (16',.90 MIL) | T7 - YELLOW EDGELINE (16',.90 MIL) |
| TL - WHITE SOLID LANE LINE (16',.90 MIL) | T8 - 2FT.-6FT./SP WHITE MINISKIP (4',.90 MIL) |
| TM - 10FT. YELLOW SKIP (16',.90 MIL) | T9 - 2FT.-6FT./SP YELLOW MINISKIP (4',.90 MIL) |
| TN - WHITE GORELINE (8',.90 MIL) | T10 - 3FT.-3FT./SP WHITE MINISKIP (12',.90 MIL) |
| TO - WHITE DIAGONAL (8',.90 MIL) | T11 - 2FT.-6FT./SP WHITE MINISKIP (16',.90 MIL) |
| TP - YELLOW DIAGONAL (8',.90 MIL) | T12 - 2FT.-6FT./SP YELLOW MINISKIP (16',.90 MIL) |
| TQ - WHITE CROSSWALK LINE (8',.90 MIL) | T13 - 3FT.-9FT./SP WHITE MINISKIP (18',.90 MIL) |
| TR - WHITE SOLID LANE LINE (8',.90 MIL) | T14 - 3FT.-9FT./SP WHITE MINISKIP (12',.90 MIL) |
| TS - WHITE GORELINE (12',.90 MIL) | T15 - YELLOW SINGLE CENTER (16',.90 MIL) |
| TT - WHITE SOLID LANE LINE (12',.90 MIL) | T16 - YELLOW DOUBLE CENTER (16',.90 MIL) |
| | T17 - 3FT.-3FT./SP WHITE MINISKIP ENTRANCE LINE (18',.90 MIL) |

THERMOPLASTIC MARKING SYMBOLS

- | | |
|--|--|
| UA - LEFT TURN ARROW (90 MIL) | UU - FISH-HOOK STRAIGHT ARROW (90 MIL) |
| UB - RIGHT TURN ARROW (90 MIL) | UV - FISH-HOOK LEFT/STRAIGHT ARROW (90 MIL) |
| UC - STRAIGHT ARROW (90 MIL) | UW - FISH-HOOK RIGHT/STRAIGHT ARROW (90 MIL) |
| UD - COMBO. LEFT/STRAIGHT ARROW (90 MIL) | UX - FISH-HOOK LEFT/RIGHT ARROW (90 MIL) |
| UE - COMBO. RIGHT/STRAIGHT ARROW (90 MIL) | UY - FISH-HOOK LEFT/RIGHT/STRAIGHT ARROW (90 MIL) |
| UF - COMBO. LEFT/RIGHT ARROW (90 MIL) | UZ - FISH-HOOK W/CIRCLE STRAIGHT ARROW (90 MIL) |
| UG - COMBO. LEFT/RIGHT/STRAIGHT ARROW (90 MIL) | |
| UH - HANDICAP PARKING (90 MIL) | YA - FISH-HOOK W/CIRCLE LEFT ARROW (90 MIL) |
| UI - ALPHANUMERIC CHAR. (90 MIL) | YB - FISH-HOOK W/CIRCLE LEFT/STRAIGHT ARROW (90 MIL) |
| UJ - BICYCLE SYMBOL (90 MIL) | YC - FISH-HOOK W/CIRCLE LEFT/RIGHT/STRAIGHT ARROW (90 MIL) |
| UK - BICYCLE STRAIGHT ARROW (90 MIL) | YD - COMBO. LEFT/U-TURN ARROW (90 MIL) |
| UL - BICYCLE CHAR. (90 MIL) | MA - PERMANENT RAISED MARKER (YELLOW & YELLOW) |
| UM - 12' YIELD LINE TRIANGLE (90 MIL) | MB - PERMANENT RAISED MARKER (CRYSTAL & RED) |
| UN - 24' YIELD LINE TRIANGLE (90 MIL) | MC - PERMANENT RAISED MARKER (YELLOW & RED) |
| UO - BICYCLE LEFT ARROW (90 MIL) | MD - PERMANENT RAISED MARKER (YELLOW) |
| UP - MERGE ARROW (90 MIL) | ME - SNOWPLOWABLE MARKER (YELLOW & YELLOW) |
| UQ - RAMP ARROW SYMBOL (90 MIL) | MF - SNOWPLOWABLE MARKER (CRYSTAL & RED) |
| UR - SHARROW (90 MIL) | MG - SNOWPLOWABLE MARKER (YELLOW & RED) |
| US - BICYCLE LOOP DETECTOR (90 MIL) | ML - PERMANENT RAISED MARKER (CRYSTAL & CRYSTAL) |
| UT - U-TURN ARROW (90 MIL) | MO - SNOWPLOWABLE MARKER (CRYSTAL & CRYSTAL) |

SIGNALIZED RCI ON NC 16
AT OLD PLANK RD.(SR-2006) AND
PLEASANT GROVE RD.(SR-2008)

SCALE	1"=50'		REVISIONS
DATE	3-2022		
DWG. BY	TBL		
DESIGN BY	TBL		
APPROVED	JDH		

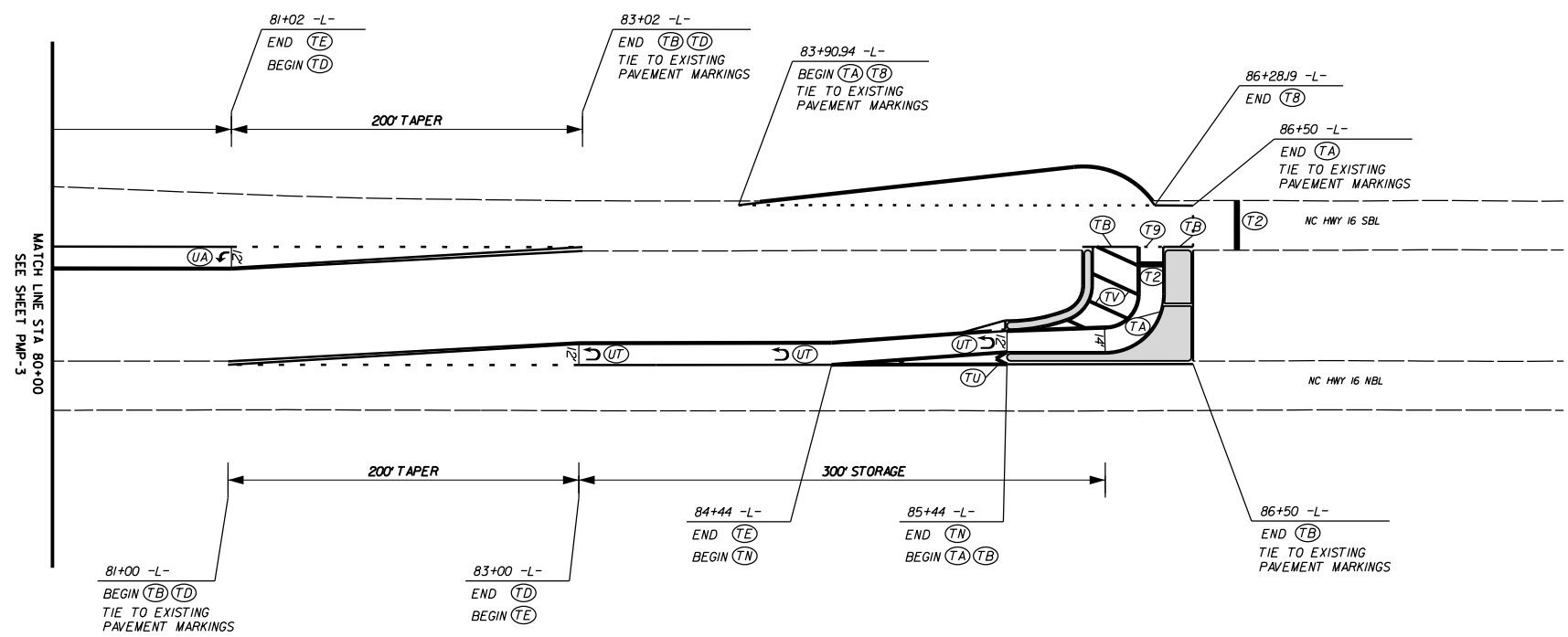

PAVEMENT MARKING SCHEDULE

THERMOPLASTIC MARKING LINES

- | | |
|--|---|
| TA - WHITE EDGELINE (4',90 MIL) | TU - WHITE DIAGONAL (12',90 MIL) |
| TB - YELLOW EDGELINE (4',90 MIL) | TV - YELLOW DIAGONAL (12',90 MIL) |
| TC - 10FT. WHITE SKIP (4',90 MIL) | TW - WHITE LINE, RR X (16',90 MIL) |
| TD - 3FT.-9FT./SP WHITE MINISKIP (4',90 MIL) | TX - WHITE STOPBAR (24',90 MIL) |
| TE - WHITE SOLID LANE LINE (4',90 MIL) | TY - WHITE CROSSWALK LINE (24',90 MIL) |
| TF - 10FT. YELLOW SKIP (4',90 MIL) | TZ - WHITE RUMBLE STRIP (4',240 MIL) |
| TH - YELLOW SINGLE CENTER (4',90 MIL) | T1 - YELLOW RUMBLE STRIP (4',240 MIL) |
| TI - YELLOW DOUBLE CENTER (4',90 MIL) | T2 - WHITE EDGELINE (6',90 MIL) |
| TJ - 10FT. WHITE SKIP (6',90 MIL) | T3 - YELLOW EDGELINE (6',90 MIL) |
| TK - 3FT.-9FT./SP WHITE MINISKIP (6',90 MIL) | T4 - 2FT.-6FT./SP WHITE MINISKIP (4',90 MIL) |
| TL - WHITE SOLID LANE LINE (6',90 MIL) | T5 - 2FT.-6FT./SP YELLOW MINISKIP (4',90 MIL) |
| TM - 10FT. YELLOW SKIP (6',90 MIL) | T6 - 3FT.-3FT./SP WHITE MINISKIP (12',90 MIL) |
| TN - WHITE GORELINE (8',90 MIL) | T7 - 2FT.-6FT./SP WHITE MINISKIP (6',90 MIL) |
| TO - WHITE DIAGONAL (8',90 MIL) | T8 - 2FT.-6FT./SP YELLOW MINISKIP (6',90 MIL) |
| TP - YELLOW DIAGONAL (8',90 MIL) | T9 - 3FT.-9FT./SP WHITE MINISKIP (8',90 MIL) |
| TQ - WHITE CROSSWALK LINE (8',90 MIL) | T10 - 3FT.-9FT./SP WHITE MINISKIP (12',90 MIL) |
| TR - WHITE SOLID LANE LINE (8',90 MIL) | T11 - 2FT.-6FT./SP WHITE MINISKIP (6',90 MIL) |
| TS - WHITE GORELINE (12',90 MIL) | T12 - 2FT.-6FT./SP YELLOW MINISKIP (6',90 MIL) |
| TT - WHITE SOLID LANE LINE (12',90 MIL) | T13 - 3FT.-9FT./SP WHITE MINISKIP (8',90 MIL) |
| | T14 - 3FT.-9FT./SP WHITE MINISKIP (12',90 MIL) |
| | T15 - YELLOW SINGLE CENTER (6',90 MIL) |
| | T16 - YELLOW DOUBLE CENTER (6',90 MIL) |
| | T17 - 3FT.-3FT./SP WHITE MINISKIP ENTRANCE LINE (8',90 MIL) |

THERMOPLASTIC MARKING SYMBOLS

- | | |
|--|--|
| UA - LEFT TURN ARROW (90 MIL) | UU - FISH-HOOK STRAIGHT ARROW (90 MIL) |
| UB - RIGHT TURN ARROW (90 MIL) | UV - FISH-HOOK LEFT/STRAIGHT ARROW (90 MIL) |
| UC - STRAIGHT ARROW (90 MIL) | UW - FISH-HOOK RIGHT/STRAIGHT ARROW (90 MIL) |
| UD - COMBO. LEFT/STRAIGHT ARROW (90 MIL) | UX - FISH-HOOK LEFT/RIGHT ARROW (90 MIL) |
| UE - COMBO. RIGHT/STRAIGHT ARROW (90 MIL) | UY - FISH-HOOK LEFT/RIGHT/STRAIGHT ARROW (90 MIL) |
| UF - COMBO. LEFT/RIGHT ARROW (90 MIL) | UZ - FISH-HOOK W/CIRCLE STRAIGHT ARROW (90 MIL) |
| UG - COMBO. LEFT/RIGHT/STRAIGHT ARROW (90 MIL) | |
| UH - HANDICAP PARKING (90 MIL) | YA - FISH-HOOK W/CIRCLE LEFT ARROW (90 MIL) |
| UI - ALPHANUMERIC CHAR. (90 MIL) | YB - FISH-HOOK W/CIRCLE LEFT/STRAIGHT ARROW (90 MIL) |
| UJ - BICYCLE SYMBOL (90 MIL) | YC - FISH-HOOK W/CIRCLE LEFT/RIGHT/STRAIGHT ARROW (90 MIL) |
| UK - BICYCLE STRAIGHT ARROW (90 MIL) | YD - COMBO. LEFT/U-TURN ARROW (90 MIL) |
| UL - BICYCLE CHAR. (90 MIL) | MA - PERMANENT RAISED MARKER (YELLOW & YELLOW) |
| UM - 12" YIELD LINE TRIANGLE (90 MIL) | MB - PERMANENT RAISED MARKER (CRYSTAL & RED) |
| UN - 24" YIELD LINE TRIANGLE (90 MIL) | MC - PERMANENT RAISED MARKER (YELLOW & RED) |
| UO - BICYCLE LEFT ARROW (90 MIL) | MD - PERMANENT RAISED MARKER (YELLOW) |
| UP - MERGE ARROW (90 MIL) | ME - SNOWPLOWABLE MARKER (YELLOW & YELLOW) |
| UQ - RAMP ARROW SYMBOL (90 MIL) | MF - SNOWPLOWABLE MARKER (CRYSTAL & RED) |
| UR - SHARROW (90 MIL) | MG - SNOWPLOWABLE MARKER (YELLOW & RED) |
| US - BICYCLE LOOP DETECTOR (90 MIL) | ML - PERMANENT RAISED MARKER (CRYSTAL & CRYSTAL) |
| UT - U-TURN ARROW (90 MIL) | MO - SNOWPLOWABLE MARKER (CRYSTAL & CRYSTAL) |

SIGNALIZED RCI ON NC 16
AT OLD PLANK RD. (SR-2006) AND
PLEASANT GROVE RD. (SR-2008)

SCALE	1"=50'		REVISIONS
DATE	3-2022		
DWG. BY	TBL		
DESIGN BY	TBL		
APPROVED	JDH		

Project: W-5710AK

STATE OF NORTH CAROLINA
DIVISION OF HIGHWAYS

Project No. W-5710AK	Sheet No. Sig. 1.0
--------------------------------	------------------------------

★ PROPOSED SIGNAL

MECKLENBURG COUNTY

LOCATION: NC 16 (BROOKSHIRE BLVD) FROM BELLHAVEN BLVD TO NORTH OF PLEASANT GROVE ROAD

**TYPE OF WORK: SIGNALS
SIGNAL COMMUNICATIONS**

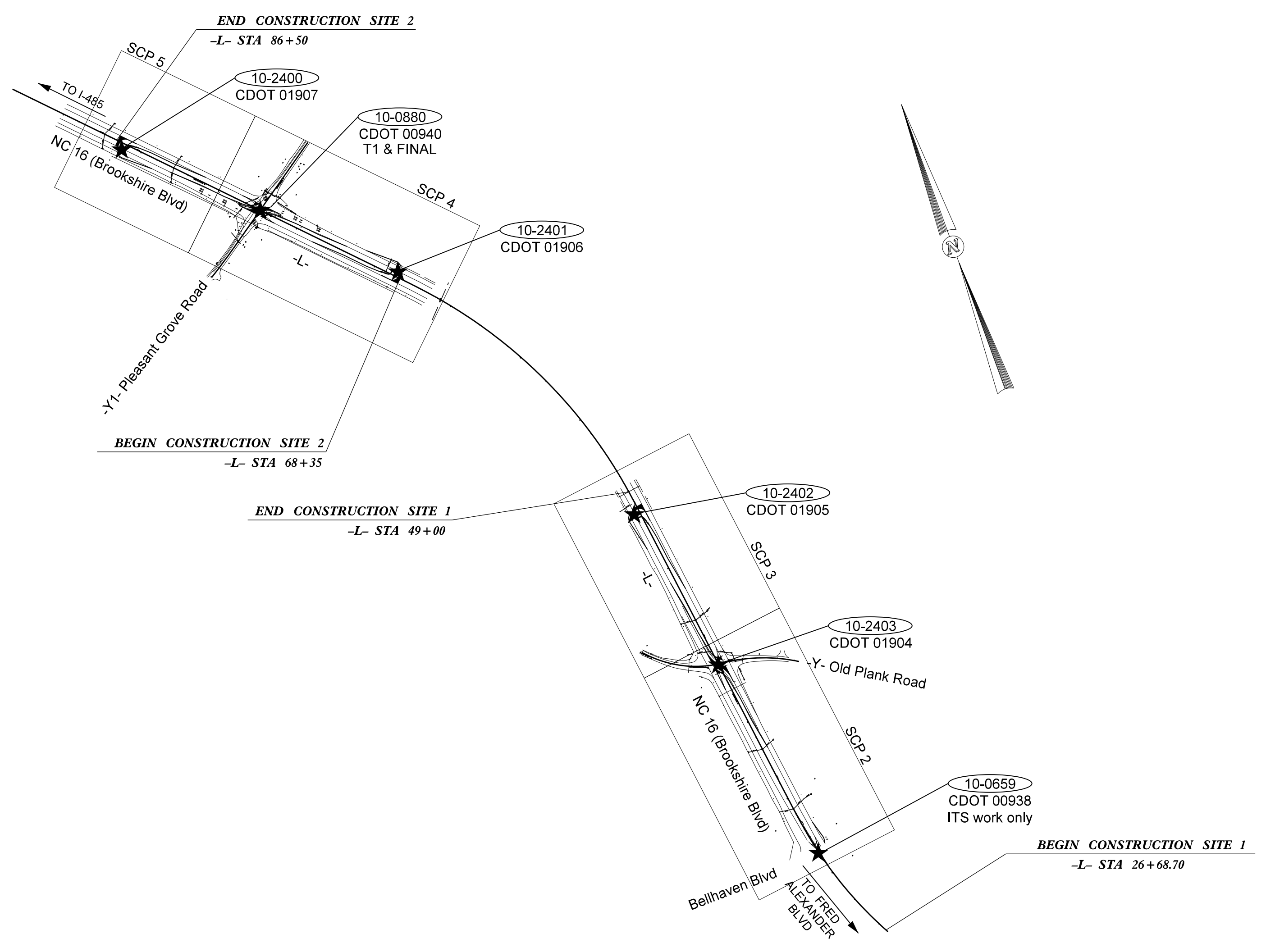
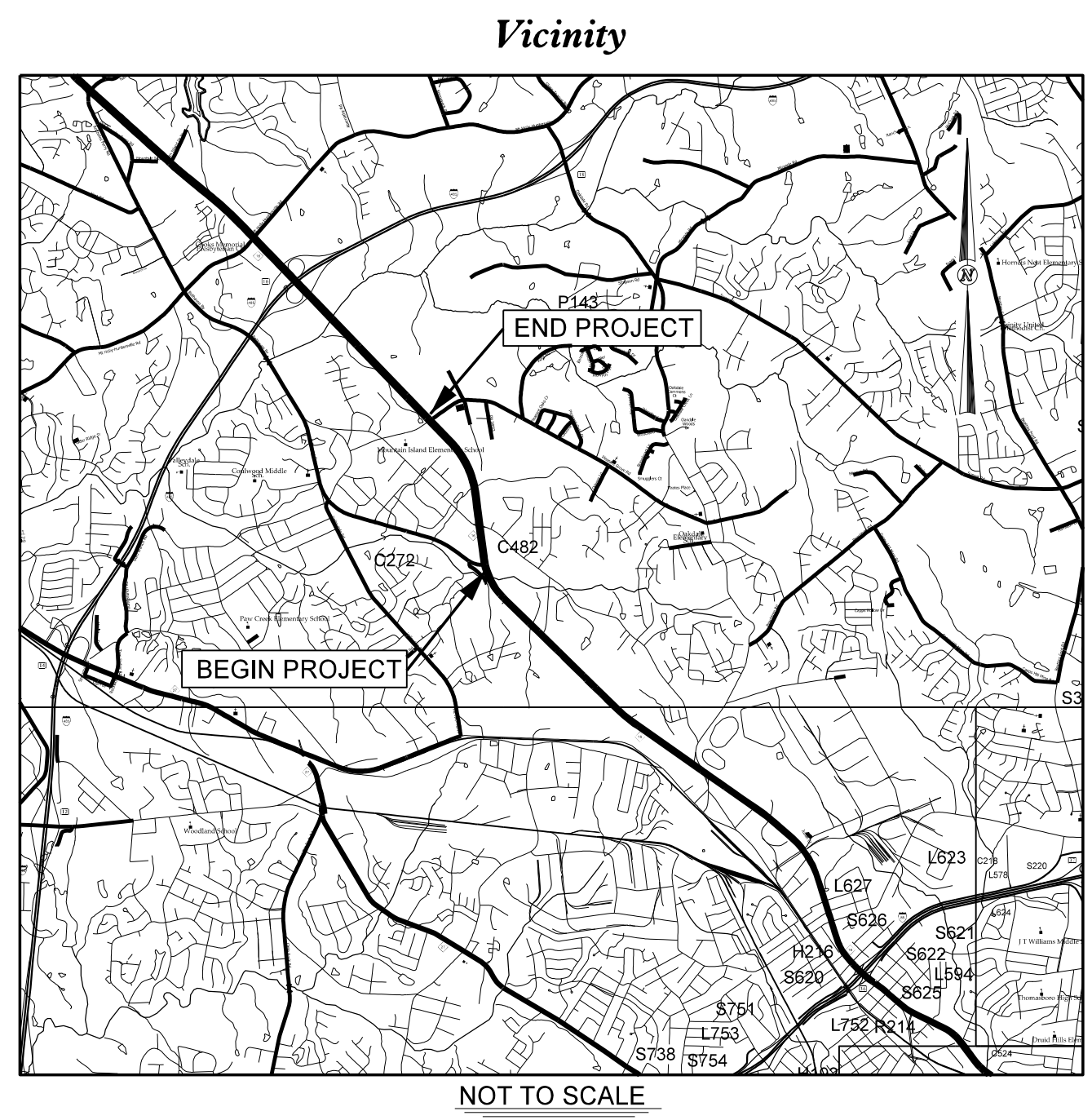

**DOCUMENT NOT CONSIDERED
FINAL UNLESS ALL
SIGNATURES COMPLETED**

Plans Prepared By:

DRMP
DRMP, Inc.
8000 Regency Parkway, Suite 110
Cary, NC 27518
NC License No. C-2213 (919) 650-1038

Refer to "Roadway Standard Drawings
NCDOT" dated January 2018 and
"Standard Specifications for Roads
and Structures" dated January 2018.

Sheet #	Reference #	Index of Plans Location/Description
---	---	TITLE SHEET
---	---	2018 STANDARD DRAWING FOR ELECTRICAL SERVICE GROUNDING AND WOOD POLES
---	---	2018 STANDARD DRAWING FOR PEDESTALS
---	---	NC 16 (BROOKSHIRE BLVD) AT OLD PLANK ROAD
---	---	NC 16 (BROOKSHIRE BLVD) SOUTHBOUND AT OLD PLANK ROAD U-TURN
---	---	NC 16 (BROOKSHIRE BLVD) NORTHBOUND AT PLEASANT GROVE ROAD U-TURN
---	---	NC 16 (BROOKSHIRE BLVD) AT PLEASANT GROVE ROAD
---	---	NC 16 (BROOKSHIRE BLVD) SOUTHBOUND AT PLEASANT GROVE ROAD U-TURN
---	---	SIGNAL COMMUNICATION PLAN CONSTRUCTION NOTES
---	---	SIGNAL COMMUNICATION PLAN LAYOUT
---	---	SIGNAL COMMUNICATION PLAN SPLICE DIAGRAMS

**NCDOT
INTELLIGENT TRANSPORTATION AND SIGNALS UNIT**
Contacts:
Tim Williams, PE - Western Region Signals Engineer
Gregg Green - Intelligent Transportation Systems Engineer

CHARLOTTE DEPARTMENT OF TRANSPORTATION
Contacts:
Nathan Conard, PE - Transportation Systems Manager
Ashley Boenisch - Intelligent Transportation Systems Engineer

Prepared for the Offices of:

**DIVISION OF HIGHWAYS
TRANSPORTATION MOBILITY AND SAFETY
DIVISION**

CHARLOTTE
TRANSPORTATION
600 East 4th Street
Charlotte, NC 28202

750 N. Greenfield Parkway, Garner, NC 27529

10-AUG-2022 12:37 P:\AW5710AK\1237\Drawings\Signals\System\W5710-AK-ITS-1\Titlesheet.dgn
DRMP
LISA M. MOON
Professional Engineer
022518
8/11/2022

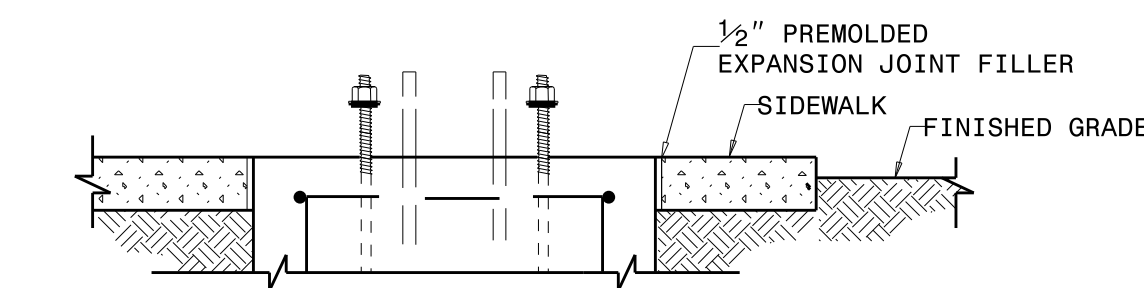
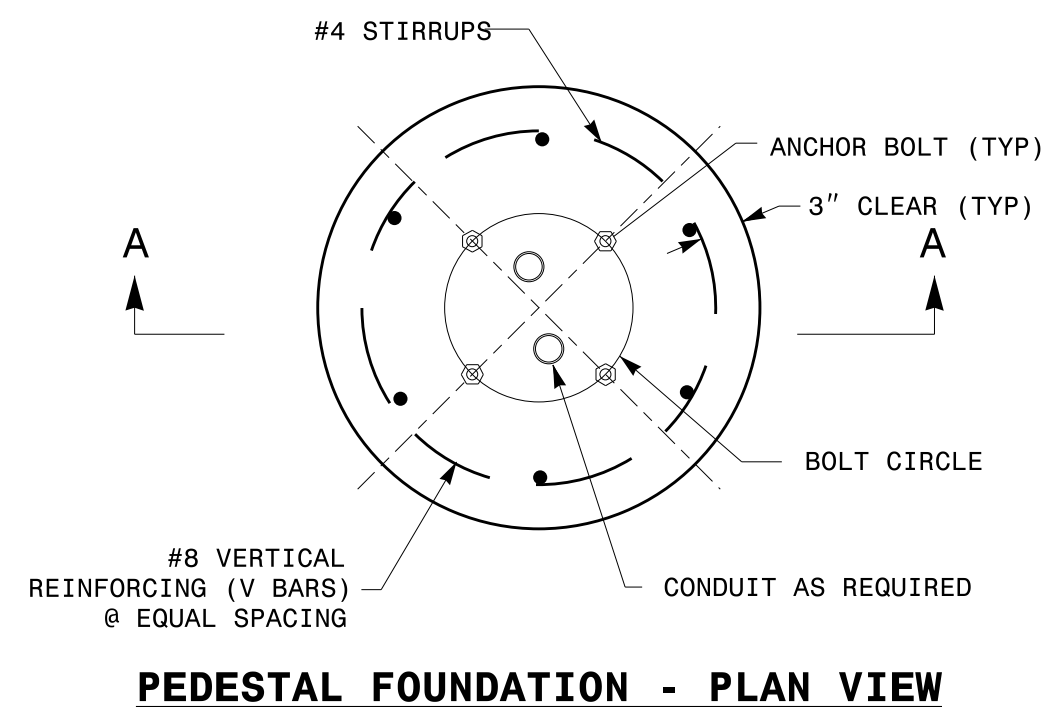

- NOTES:**
- CAST FOUNDATION AGAINST UNDISTURBED SOIL WHEREVER CONDITIONS PERMIT. IN UNSTABLE SOIL, CAST-IN-PLACE TUBE FORMS ARE ALLOWED WITH APPROVAL.
 - COMPLY WITH APPLICABLE PROVISIONS OF SECTION 825 FOR CONCRETE CONSTRUCTION.
 - USE CLASS "A" CONCRETE THAT MEETS THE REQUIREMENTS OF SECTION 1000 WITH A COMPRESSION STRENGTH AT 28 DAYS OF $F'c = 3000$ PSI (MIN.).
 - USE ASTM GRADE 60 DEFORMED BARS FOR ALL REINFORCING STEEL.
 - GRADE IS ASSUMED TO BE (8H:1V) OR FLATTER. FOUNDATION SIZE AND DEPTHS ARE BASED ON THE FOLLOWING SOIL DESIGN PARAMETERS:
 - A. SANDY TYPE SOIL
 - B. NO GROUND WATER WITHIN 5'-0" OF SURFACE ELEVATION
 - C. WIND SPEED NOT TO EXCEED 140 MPH
 IF ACTUAL CONDITIONS VARY SUBSTANTIALLY FROM THOSE ASSUMED, THE FOUNDATION DEPTH MAY BE ADJUSTED. IN THIS CASE, CONTACT THE ENGINEER.
 - MAINTAIN AT LEAST 3" COVER ON ALL REINFORCEMENT.
 - ORIENT CONDUIT AS REQUIRED BY THE DESIGN OR AS DICTATED BY FIELD CONDITIONS.
 - USE ADHESIVE ANCHOR FOR THREADED COUPLING INSERT. FOR TYPE I MINIMUM DEPTH NECESSARY IS 0'-4 1/2" AND FOR TYPE II MINIMUM DEPTH NECESSARY IS 0'-6 5/8". FOLLOW MANUFACTURER'S INSTALLATION INSTRUCTIONS.

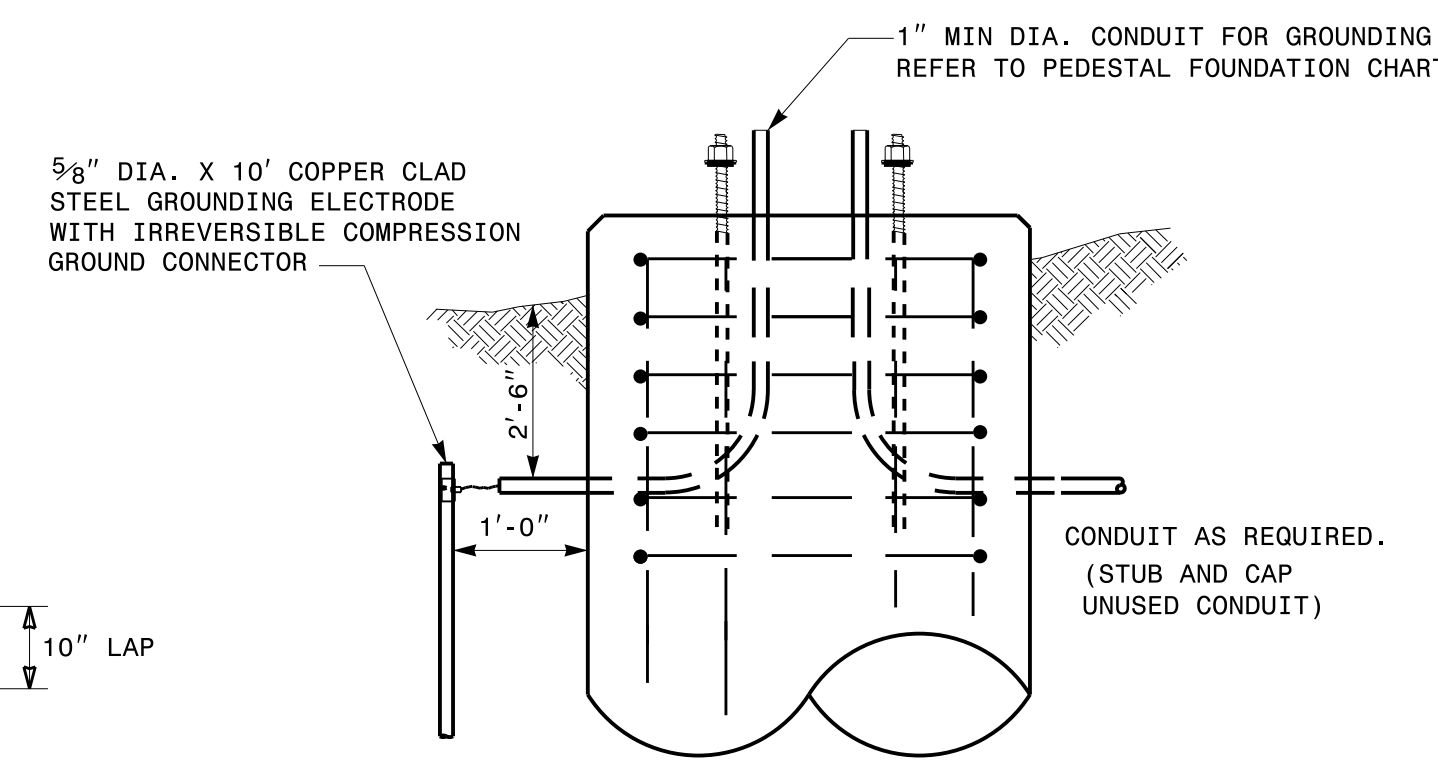
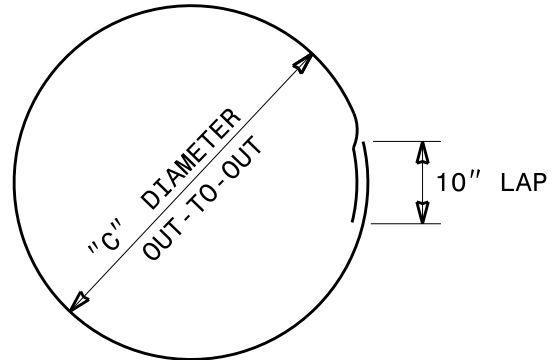
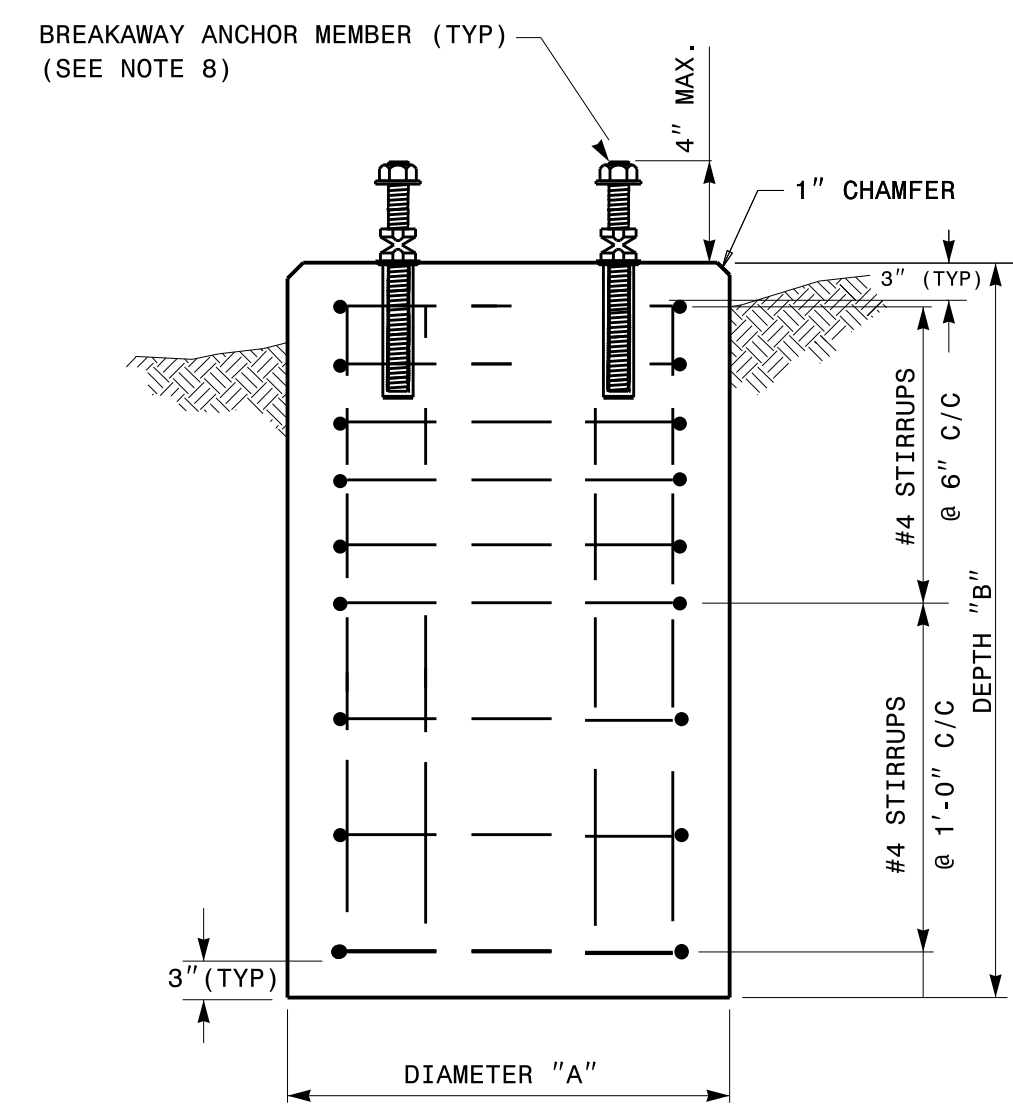
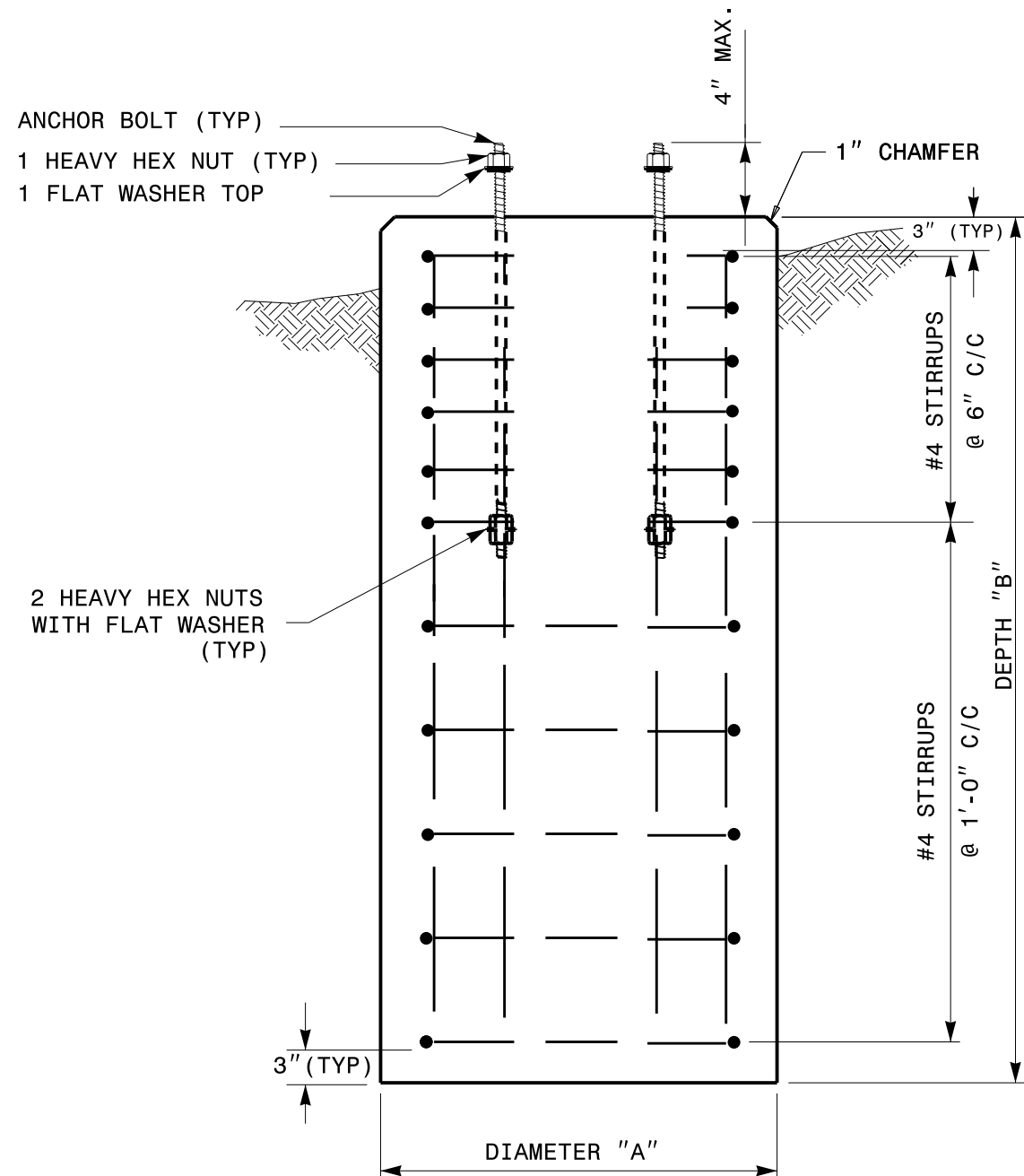

PEDESTAL FOUNDATION TYPE AND SIZE							
TYPE	PEDESTAL DESCRIPTION	SIZE			ANCHOR BOLT		INSTALL GROUNDING SYSTEM (YES/NO)
		DIAMETER "A" FT	DEPTH "B" FT	CONCRETE VOLUME CY	DIAMETER (MIN.) IN	LENGTH FT-IN	
I	PEDESTRIAN PUSHBUTTON	2'-0"	3'-6"	.41	1/2	1'-6"	NO
II	NORMAL-DUTY	2'-0"	5'-0"	.58	3/4	2'-0"	YES
III	HEAVY-DUTY	2'-6"	7'-0"	1.27	1	4'-0"	YES

REINFORCING STEEL SCHEDULE												
TYPE	V-BAR				STIRRUP							
	SIZE #	QTY	LENGTH	WEIGHT LBS	QUANTITY			LENGTH	DIAMETER "C" FT	OVERLAP MIN.	WEIGHT LBS	TOTAL STEEL WEIGHT LBS
					ON 6" CENTERS	ON 12" CENTERS	TOTAL					
I	8	6	3'-0"	56	4	0	4	5'-7"	1'-6"	0'-10"	15	71
II	8	6	4'-6"	86	4	5	3	5'-7"	1'-6"	0'-10"	30	116
III	8	6	6'-6"	122	4	7	4	7'-2"	2'-0"	0'-10"	53	175

STATE OF NORTH CAROLINA
DEPT. OF TRANSPORTATION
DIVISION OF HIGHWAYS
RALEIGH, N.C.

ENGLISH STANDARD DRAWING FOR
PEDESTALS
FOUNDATIONS

SHEET 1 OF 1
1743D01

See Plate for Title

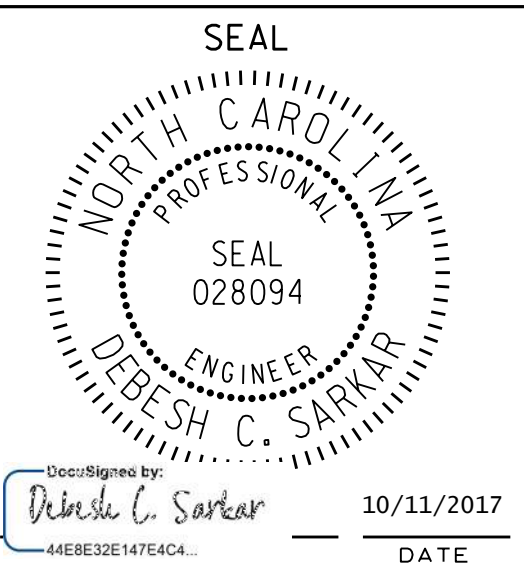
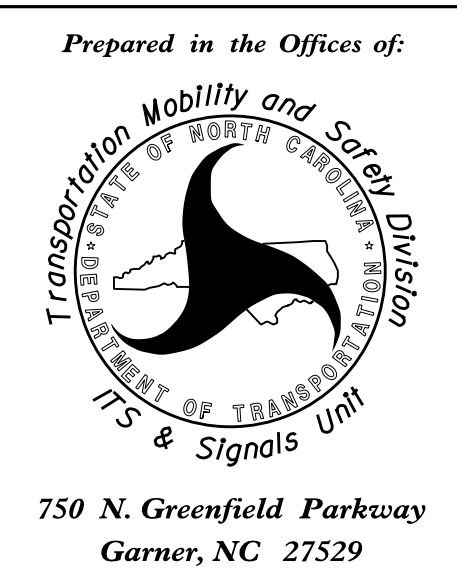

DOCUMENT NOT CONSIDERED
FINAL UNLESS ALL
SIGNATURES COMPLETED

750 N. Greenfield Parkway
Garner, NC 27529

10/11/2017
DATE

11-10CT-2017_08c03
11-2018_S14 Drawings#Plate_Sheets#2018_Plate_Sheet - .dgn
r:\rough

1-18 STATE OF NORTH CAROLINA DEPT. OF TRANSPORTATION DIVISION OF HIGHWAYS RALEIGH, N.C.

ENGLISH STANDARD DRAWING FOR
ELECTRICAL SERVICE GROUNDING
GROUNDING AND BONDING

SHEET 1 OF 1
1700D01

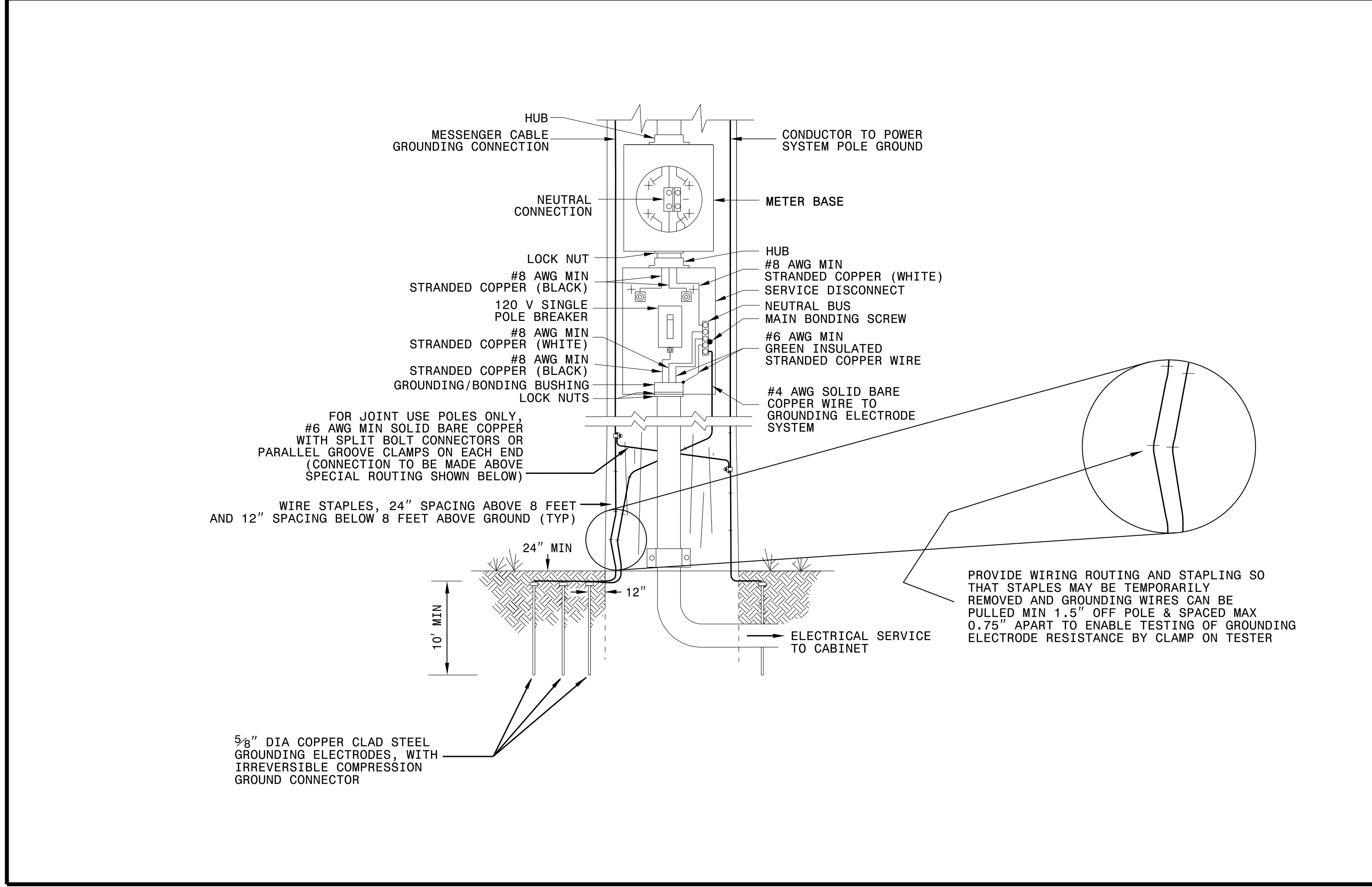

1-18 STATE OF NORTH CAROLINA DEPT. OF TRANSPORTATION DIVISION OF HIGHWAYS RALEIGH, N.C.

ENGLISH STANDARD DRAWING FOR
WOOD POLES
METHODS OF ATTACHMENT AND GROUNDING

SHEET 1 OF 1
1720D01

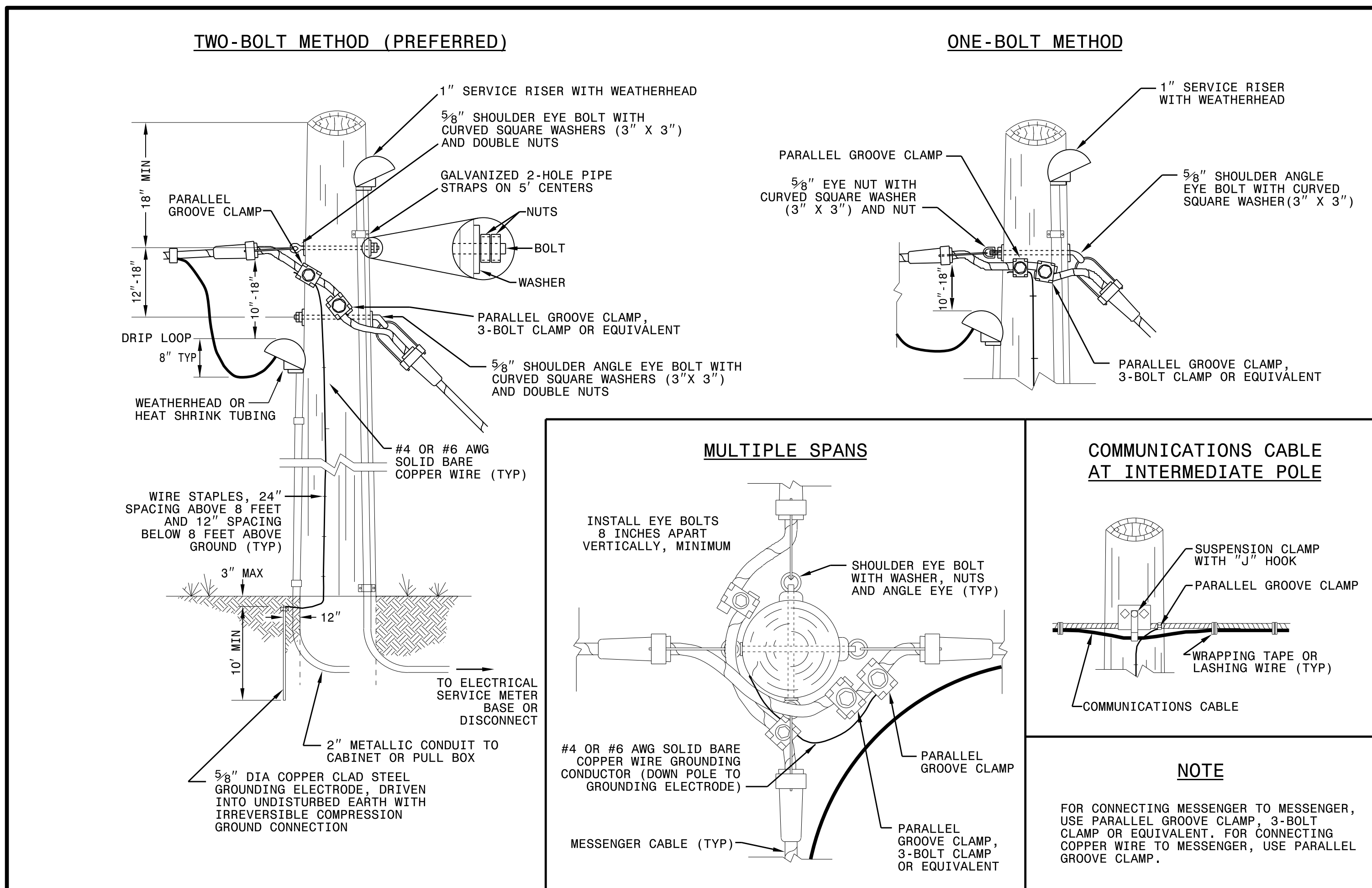

DOCUMENT NOT CONSIDERED
FINAL UNLESS ALL
SIGNATURES COMPLETED

See Plate for Title

Prepared in the Offices of:

SEAL

MOHD A. ASLAM I
ENGINEER
032108

750 N. Greenfield Parkway
Garner, NC 27529

10/11/2017
DATE

11-0CT-2017_08-56
11-2018_S14_DrawingPlate_Sheets2018_Plate_Sheet.dgn
r:\rough

Signal ID 01904 / NCDOT 10-2403

NC 16 (Brookshire Blvd) @ Old Plank Rd

INDEX OF SHEETS	
Cover Sheet	SIG2.0
Signal Plan	SIG2.1
Signal Details	SIG2.2
Splice Detail	SIG2.3
Signal Wiring Diagram	SIG2.4
Low Voltage Wiring Diagram	SIG2.5
Miscellaneous Details	SIG2.6
TOTAL SHEETS 7	

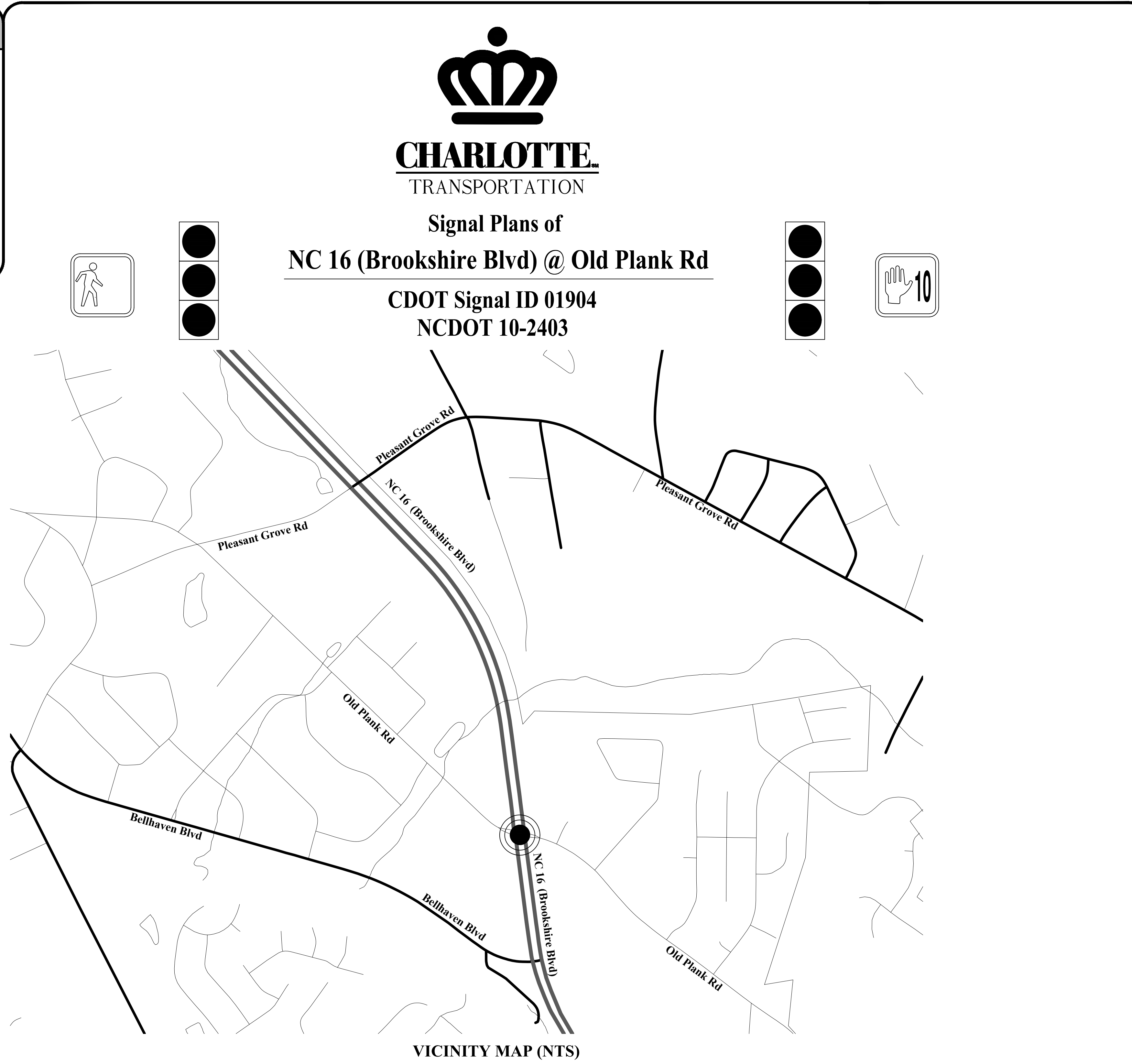

LEGEND		
PROPOSED	DESCRIPTION	EXISTING
	CONTROL BOX	
	METER PEDESTAL	
	PULL BOX	
	STEEL POLE	
	MAST ARM	
	PED PEDESTAL	
	UTILITY POLE	
	ANCHOR	
	SIGNAL HEAD	
	VIDEO CAMERA	
	OPTICOM	
	OBSERVATION CAM	
	DETECTOR	
	CONDUIT	
	INTERCONNECT	
	EDGE OF PVMT.	
	CURB & GUTTER	
	TUBULAR MARKER	
	GROUND SIGN	
	OVERHEAD SIGN	
	DOUBLE YELLOW	
	STOP BAR	
	WHITE SKIP	
	WHITE MINI	
	PAVEMENT ARROW	
	PROPERTY LINE	
	ROW	
	UTILITIES TELEPHONE UG CABLE SUE	
	UTILITIES SANITARY SEWER UG LINE	
	UTILITIES WATER UG LINE SUE	
	UTILITIES GAS UG LINE SUE	
	UTILITIES TELEPHONE UG FO SUE	
	OTHER CULTURE FENCE LINE	

PULLBOX ID		
	SIZE	PULLBOX TYPE
①	13"x24"x12"	LOOP
②	17"x30"x30"	FIBER OPTIC
③	24"x36"x24"	CONTROLLER / FIBER
④	30"x48"x36"	CONTROLLER
⑤	24"x24"x12"	CONTROLLER
UH-2	24"x36"x30"	FIBER SPLICE

NOTE:
PULLBOX MATERIAL MUST MEET OR EXCEED THE 2018 NCDOT STANDARD TRAFFIC SIGNAL SPECIFICATIONS.

PLANS PREPARED FOR:

City of Charlotte
 Department of Transportation
 600 East 4th Street Charlotte, NC 28202
 Phone: (704) 336-4119
 Fax: (704) 336-4400

PLAN NOTES

- ALL PAVEMENT MARKING DIMENSIONS ARE APPROXIMATE.
- SIGNAL SHALL BE INSTALLED IN ACCORDANCE WITH THE LATEST NCDOT STANDARD SPECIFICATIONS AND PROJECT SPECIAL PROVISIONS.
- CITY WILL SUPPLY STREET NAME SIGNS FOR INSTALLATION.
- SEE SIGNAL COMMUNICATION PLANS FOR CONSTRUCTION RELATED TO SYSTEM, SHOWN ON SIGNAL PLANS AS EXISTING.
- FYA #11, #12, #51 AND #52 WILL OPERATE PROTECTED-ONLY FROM 0500-2200 7 DAYS A WEEK, AND PROTECTED-PERMISSIVE ALL OTHER TIMES.
- ATTACHMENT HEIGHTS ARE ESTIMATED. BASED ON AVAILABLE INFORMATION AND EXISTING SURVEY ELEVATIONS. CONTRACTOR SHALL FIELD VERIFY ELEVATIONS TO ENSURE POLES OF SUFFICIENT LENGTH TO MAINTAIN MINIMUM REQUIRED CLEARANCE ABOVE THE ROADWAY.

PE SEAL

DOCUMENT NOT CONSIDERED FINAL UNLESS ALL SIGNATURES COMPLETED

PROJECT TEAM

Plans Prepared By:

DRMP, Inc.
 8000 Regency Parkway, Suite 110
 Cary, NC 27518
 NC License No. C-2213 (919) 650-1038

DESIGNER:	D. White
PROJECT ENGINEER:	C. Silver
PROJECT MANAGER:	L. Moon

Prepared for the Offices of:

CHARLOTTE
 TRANSPORTATION

750 N. Greenfield Pkwy,
 Garner, NC 27529

SHEET
SIG2.0



Plans Prepared For:
CITY OF CHARLOTTE
 DEPARTMENT OF
 TRANSPORTATION
 600 E. 4TH ST. FLOOR 200
 CHARLOTTE, NC 28202
 704.359.4191 FAX: 704.359.4660

Plans Prepared By:
DRMP
 DRMP, Inc.
 8000 Regency Parkway, Suite 110
 Charlotte, NC 28226
 (919) 659-1088
 NC License No. C-2216

NO.	DATE	BY	REVISION DESCRIPTION

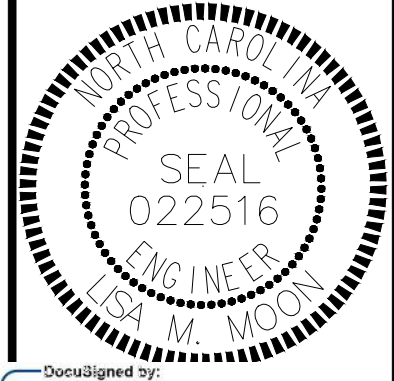

Designed by
Lisa M. Moon 3/25/2022
 (SAC58883200421)

DOCUMENT NOT CONSIDERED FINAL UNLESS ALL SIGNATURES COMPLETED

W-5710AK	JOB NO.	D/JW	PREPARED BY	03-2022	DATE
01904	SIGNAL NO.	10-2403	NC DOT ID NO.	L. MOON	APPROVER

**NC 16 (BROOKSHIRE BLVD)
 @ OLD PLANK RD**

SHEET **SIG2.1** OF **SIG2.6**

SIGNAL PLAN

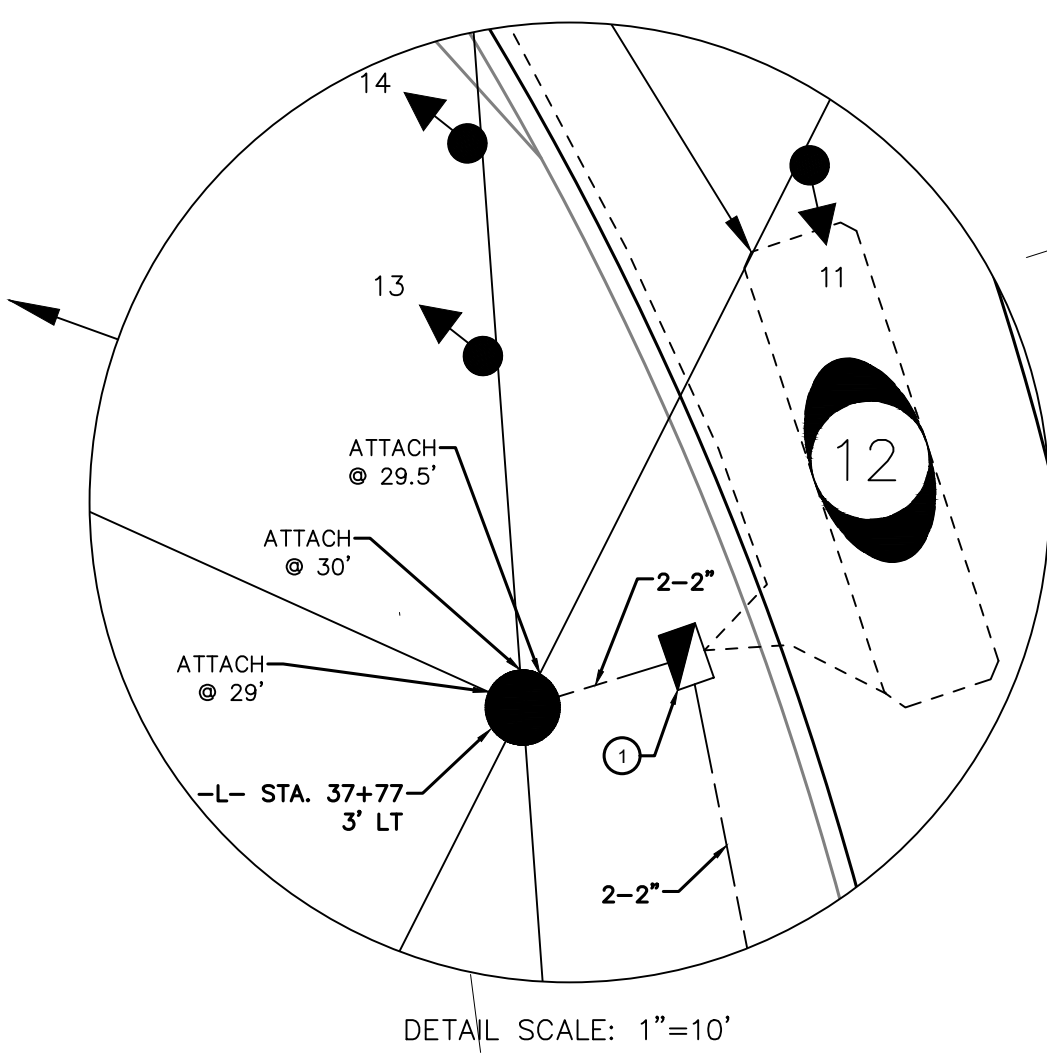
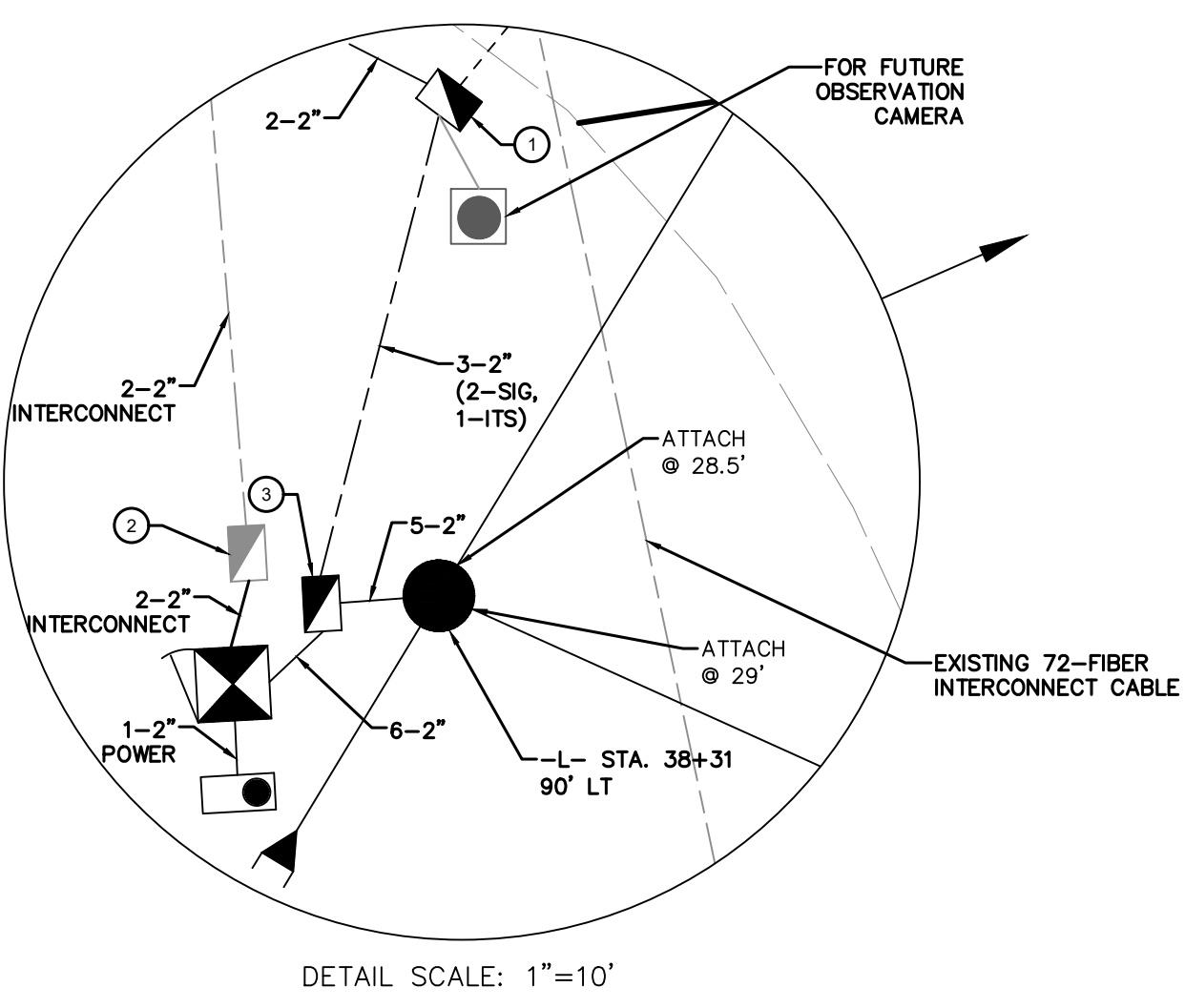
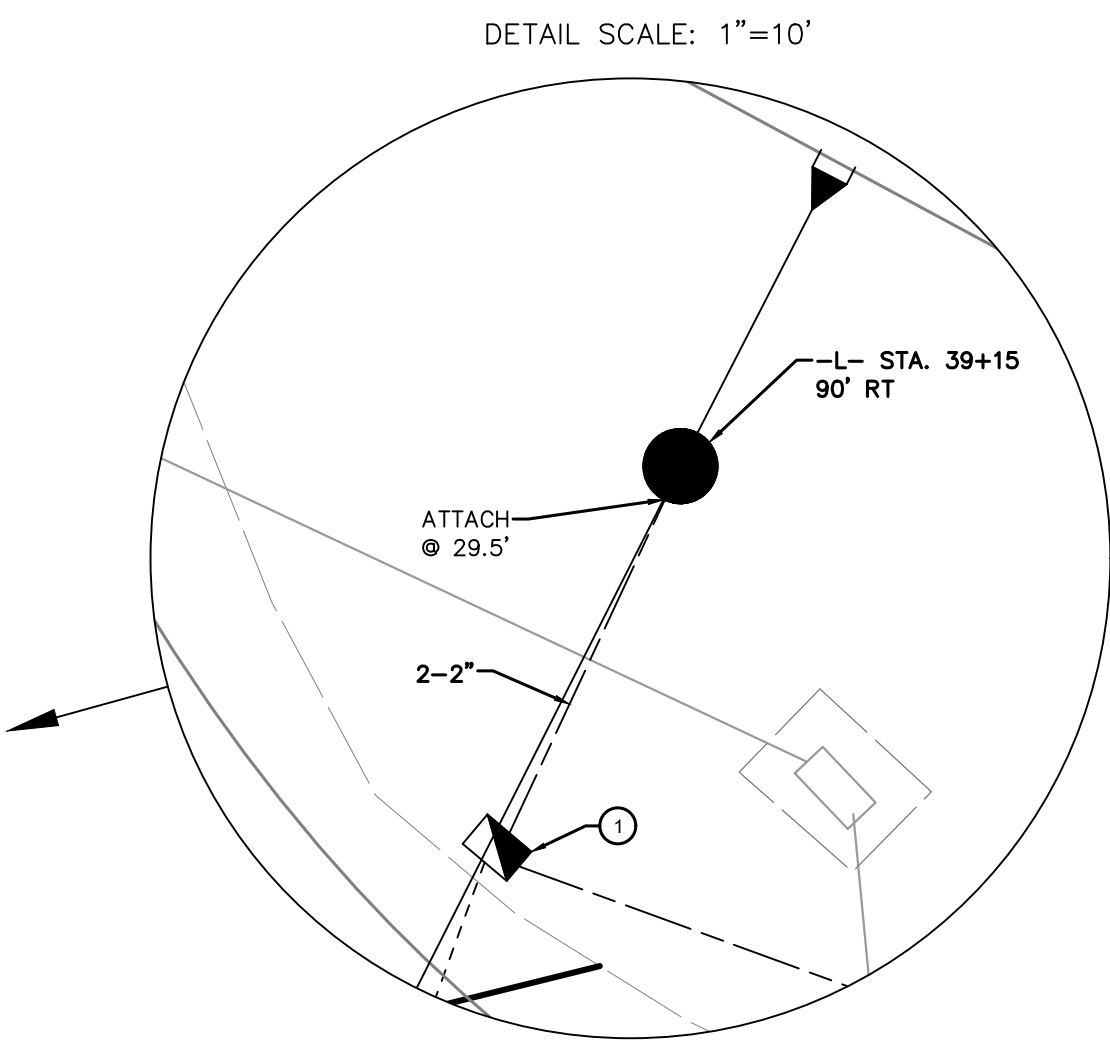
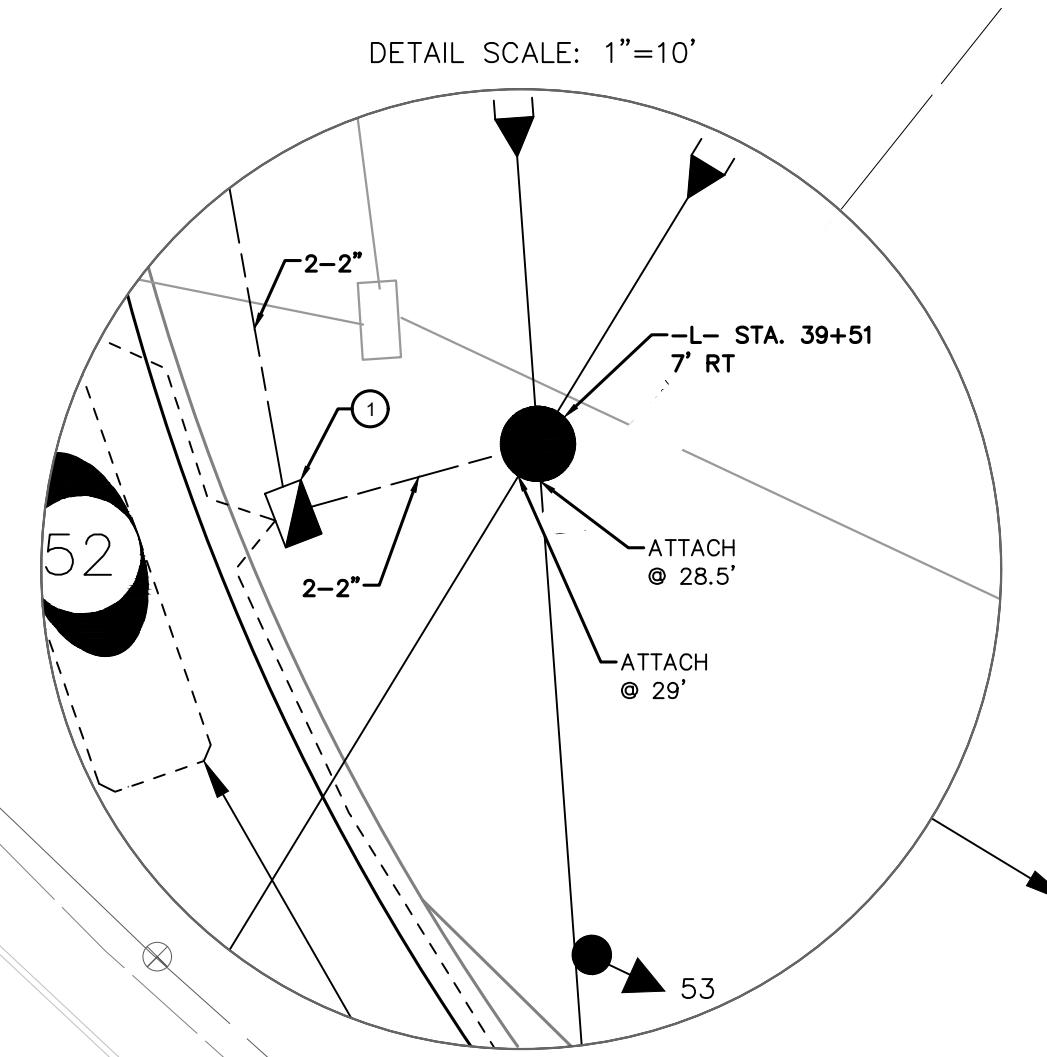
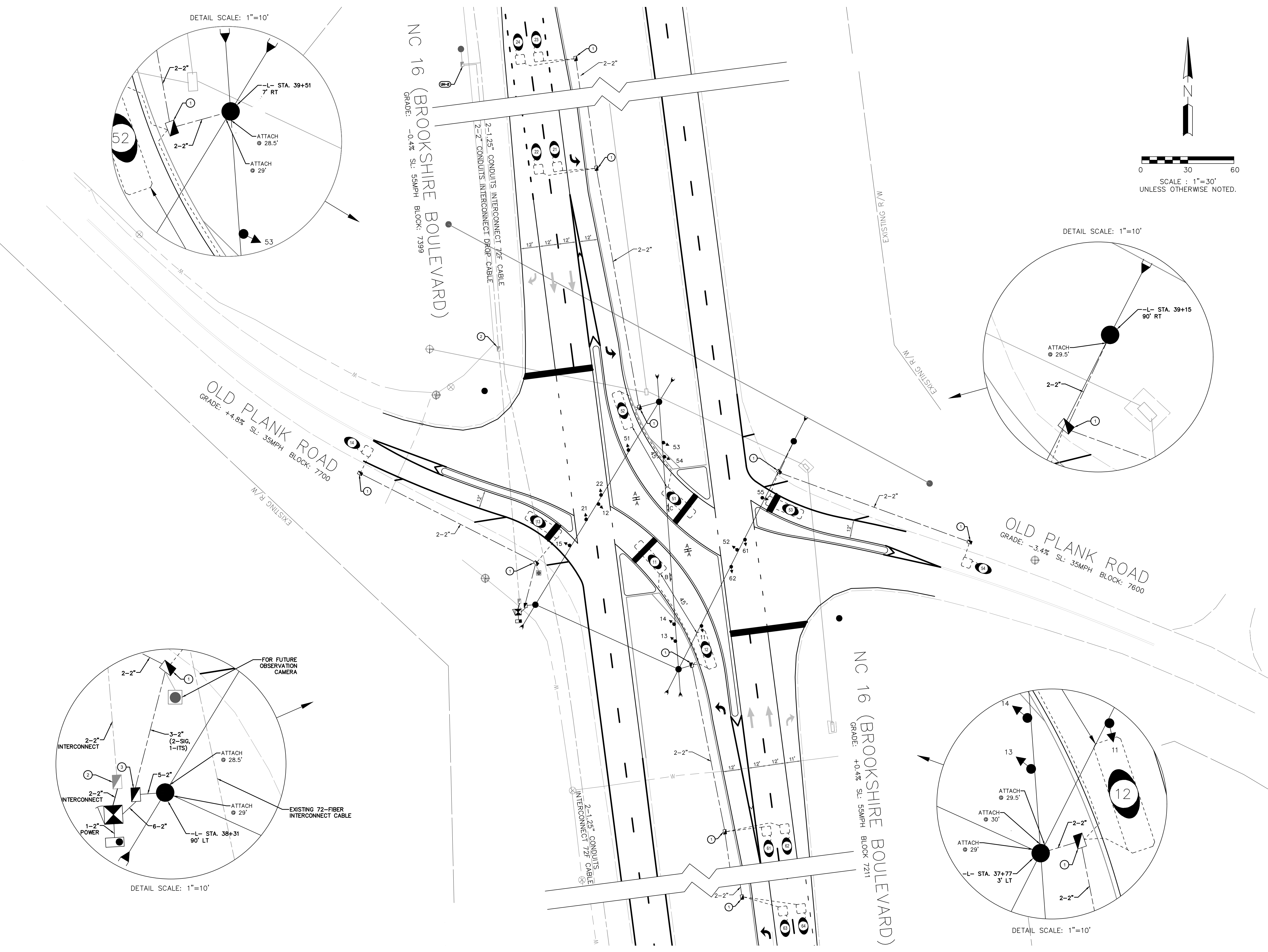
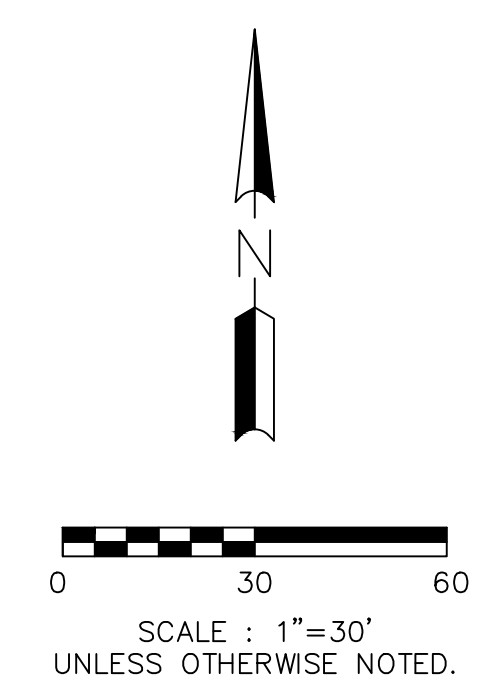

SIGNAL PHASING		SIGNAL SEQUENCE								OVERLAP PHASE				TURNING MOVEMENT COUNT								SIGN ID																																																																																																																																							
<p>Ring Configuration 1,2,3,4,5,6,7,8</p> <div style="display: flex; justify-content: space-around;"> <div style="text-align: center;"> <p>1 </p> <p>2 </p> <p>3 NOT USED</p> <p>4 NOT USED</p> </div> <div style="text-align: center;"> <p>5 </p> <p>6 </p> <p>7 NOT USED</p> <p>8 NOT USED</p> </div> </div>	<table border="1" style="width:100%; border-collapse: collapse; font-size: 8px;"> <tr> <th>RING 1</th> <th colspan="2">PHASE 1</th> <th colspan="2">PHASE 2</th> <th colspan="2">PHASE 3</th> <th colspan="2">PHASE 4</th> <th rowspan="2">FLASH</th> </tr> <tr> <th>SIGNAL ID NUMBER</th> <th>R/W</th> <th>OTH</th> <th>R/W</th> <th>OTH</th> <th>R/W</th> <th>OTH</th> <th>R/W</th> <th>OTH</th> </tr> <tr> <td>11,12</td> <td>▶</td> <td>◀</td> <td></td> <td></td> <td></td> <td></td> <td></td> <td></td> <td>▶</td> </tr> <tr> <td>13,14,15</td> <td>▶</td> <td>◀</td> <td></td> <td></td> <td></td> <td></td> <td></td> <td></td> <td>▶</td> </tr> <tr> <td>21,22</td> <td></td> <td></td> <td>G</td> <td>Y</td> <td></td> <td></td> <td></td> <td></td> <td>▶</td> </tr> </table> <table border="1" style="width:100%; border-collapse: collapse; font-size: 8px;"> <tr> <th>RING 2</th> <th colspan="2">PHASE 5</th> <th colspan="2">PHASE 6</th> <th colspan="2">PHASE 7</th> <th colspan="2">PHASE 8</th> <th rowspan="2">FLASH</th> </tr> <tr> <th>SIGNAL ID NUMBER</th> <th>R/W</th> <th>OTH</th> <th>R/W</th> <th>OTH</th> <th>R/W</th> <th>OTH</th> <th>R/W</th> <th>OTH</th> </tr> <tr> <td>51,52</td> <td>▶</td> <td>◀</td> <td></td> <td></td> <td></td> <td></td> <td></td> <td></td> <td>▶</td> </tr> <tr> <td>53,54,55</td> <td>▶</td> <td>◀</td> <td></td> <td></td> <td></td> <td></td> <td></td> <td></td> <td>▶</td> </tr> <tr> <td>61,62</td> <td></td> <td></td> <td>G</td> <td>Y</td> <td></td> <td></td> <td></td> <td></td> <td>▶</td> </tr> </table>	RING 1	PHASE 1		PHASE 2		PHASE 3		PHASE 4		FLASH	SIGNAL ID NUMBER	R/W	OTH	R/W	OTH	R/W	OTH	R/W	OTH	11,12	▶	◀							▶	13,14,15	▶	◀							▶	21,22			G	Y					▶	RING 2	PHASE 5		PHASE 6		PHASE 7		PHASE 8		FLASH	SIGNAL ID NUMBER	R/W	OTH	R/W	OTH	R/W	OTH	R/W	OTH	51,52	▶	◀							▶	53,54,55	▶	◀							▶	61,62			G	Y					▶	<table border="1" style="width:100%; border-collapse: collapse; font-size: 8px;"> <tr> <th>OVERLAP PHASE</th> <th>OL-A/1+2 LT/FYA</th> <th>OL-B/</th> <th>OL-A/5+6 LT/FYA</th> <th>OL-D/</th> </tr> <tr> <td>SIGNAL ID NUMBER</td> <td>R/W</td> <td>OTH</td> <td>R/W</td> <td>OTH</td> <td>R/W</td> <td>OTH</td> <td>R/W</td> <td>OTH</td> </tr> <tr> <td>11a,12a</td> <td>▶</td> <td>◀</td> <td></td> <td></td> <td></td> <td></td> <td></td> <td></td> </tr> <tr> <td>51a,52a</td> <td>▶</td> <td>◀</td> <td></td> <td></td> <td></td> <td></td> <td></td> <td></td> </tr> </table> <table border="1" style="width:100%; border-collapse: collapse; font-size: 8px;"> <tr> <th>OVERLAP PHASE</th> <th>OL-E/</th> <th>OL-F/</th> <th>OL-G/</th> <th>OL-H/</th> </tr> <tr> <td>SIGNAL ID NUMBER</td> <td>R/W</td> <td>OTH</td> <td>R/W</td> <td>OTH</td> <td>R/W</td> <td>OTH</td> <td>R/W</td> <td>OTH</td> </tr> <tr> <td></td> <td></td> <td></td> <td></td> <td></td> <td></td> <td></td> <td></td> <td></td> </tr> </table>	OVERLAP PHASE	OL-A/1+2 LT/FYA	OL-B/	OL-A/5+6 LT/FYA	OL-D/	SIGNAL ID NUMBER	R/W	OTH	R/W	OTH	R/W	OTH	R/W	OTH	11a,12a	▶	◀							51a,52a	▶	◀							OVERLAP PHASE	OL-E/	OL-F/	OL-G/	OL-H/	SIGNAL ID NUMBER	R/W	OTH	R/W	OTH	R/W	OTH	R/W	OTH										<p style="font-size: 24px; font-weight: bold;">NOT AVAILABLE</p>	<div style="text-align: center;"> <p>A R3-24 36" x 36"</p> </div> <div style="display: flex; justify-content: space-around; margin-top: 10px;"> <div style="text-align: center;"> <p>BROOKSHIRE RUB 7200</p> </div> <div style="text-align: center;"> <p>BROOKSHIRE RUB 7400</p> </div> </div> <p style="font-size: 10px; margin-top: 10px;">NOTE: City will supply street name signs for installation</p>
RING 1	PHASE 1		PHASE 2		PHASE 3		PHASE 4		FLASH																																																																																																																																																				
SIGNAL ID NUMBER	R/W	OTH	R/W	OTH	R/W	OTH	R/W	OTH																																																																																																																																																					
11,12	▶	◀							▶																																																																																																																																																				
13,14,15	▶	◀							▶																																																																																																																																																				
21,22			G	Y					▶																																																																																																																																																				
RING 2	PHASE 5		PHASE 6		PHASE 7		PHASE 8		FLASH																																																																																																																																																				
SIGNAL ID NUMBER	R/W	OTH	R/W	OTH	R/W	OTH	R/W	OTH																																																																																																																																																					
51,52	▶	◀							▶																																																																																																																																																				
53,54,55	▶	◀							▶																																																																																																																																																				
61,62			G	Y					▶																																																																																																																																																				
OVERLAP PHASE	OL-A/1+2 LT/FYA	OL-B/	OL-A/5+6 LT/FYA	OL-D/																																																																																																																																																									
SIGNAL ID NUMBER	R/W	OTH	R/W	OTH	R/W	OTH	R/W	OTH																																																																																																																																																					
11a,12a	▶	◀																																																																																																																																																											
51a,52a	▶	◀																																																																																																																																																											
OVERLAP PHASE	OL-E/	OL-F/	OL-G/	OL-H/																																																																																																																																																									
SIGNAL ID NUMBER	R/W	OTH	R/W	OTH	R/W	OTH	R/W	OTH																																																																																																																																																					
<table border="1" style="width:100%; border-collapse: collapse; font-size: 8px;"> <thead> <tr> <th>Phase</th> <th>1</th> <th>2</th> <th>3</th> <th>4</th> <th>5</th> <th>6</th> <th>7</th> <th>8</th> </tr> </thead> <tbody> <tr> <td>% Grade</td> <td>0.4%</td> <td>-0.4%</td> <td></td> <td></td> <td>-0.4%</td> <td>0.4%</td> <td></td> <td></td> </tr> <tr> <td>Distance</td> <td>73</td> <td>149</td> <td></td> <td></td> <td>70</td> <td>109</td> <td></td> <td></td> </tr> <tr> <td>Approach Speed (mph)</td> <td>25</td> <td>55</td> <td></td> <td></td> <td>25</td> <td>55</td> <td></td> <td></td> </tr> <tr> <td>Yellow</td> <td>3.2</td> <td>5.2</td> <td></td> <td></td> <td>3.2</td> <td>5.1</td> <td></td> <td></td> </tr> <tr> <td>All Red</td> <td>2.0</td> <td>1.9</td> <td></td> <td></td> <td>2.0</td> <td>1.4</td> <td></td> <td></td> </tr> <tr> <td>Total Clearance</td> <td>5.2</td> <td>7.1</td> <td></td> <td></td> <td>5.2</td> <td>6.5</td> <td></td> <td></td> </tr> </tbody> </table>												Phase	1	2	3	4	5	6	7	8	% Grade	0.4%	-0.4%			-0.4%	0.4%			Distance	73	149			70	109			Approach Speed (mph)	25	55			25	55			Yellow	3.2	5.2			3.2	5.1			All Red	2.0	1.9			2.0	1.4			Total Clearance	5.2	7.1			5.2	6.5			<p style="font-weight: bold;">SIGNAL HEAD ID</p> <table style="width:100%; font-size: 12px;"> <tr> <td style="width: 25%;"></td> <td>11a, 12a, 51a, 52a</td> <td style="width: 25%;"></td> <td style="width: 25%;"></td> <td style="width: 25%;"></td> </tr> <tr> <td></td> <td>11a, 12a, 51a, 52a</td> <td></td> <td></td> <td></td> </tr> <tr> <td></td> <td>11a, 12a, 51a, 52a</td> <td></td> <td></td> <td></td> </tr> <tr> <td></td> <td>11, 12, 51, 52</td> <td>21,22 61,62</td> <td>13,14,15 53,54,55</td> <td></td> </tr> </table>					11a, 12a, 51a, 52a					11a, 12a, 51a, 52a					11a, 12a, 51a, 52a					11, 12, 51, 52	21,22 61,62	13,14,15 53,54,55																																																												
Phase	1	2	3	4	5	6	7	8																																																																																																																																																					
% Grade	0.4%	-0.4%			-0.4%	0.4%																																																																																																																																																							
Distance	73	149			70	109																																																																																																																																																							
Approach Speed (mph)	25	55			25	55																																																																																																																																																							
Yellow	3.2	5.2			3.2	5.1																																																																																																																																																							
All Red	2.0	1.9			2.0	1.4																																																																																																																																																							
Total Clearance	5.2	7.1			5.2	6.5																																																																																																																																																							
	11a, 12a, 51a, 52a																																																																																																																																																												
	11a, 12a, 51a, 52a																																																																																																																																																												
	11a, 12a, 51a, 52a																																																																																																																																																												
	11, 12, 51, 52	21,22 61,62	13,14,15 53,54,55																																																																																																																																																										

MALFUNCTION MANAGEMENT UNIT / CONFLICT MONITOR

PROGRAMMING DETAIL

(program card and tables as shown)

MMU PROGRAMMING CARD

OPTION	SETTING
RECURRENT PULSE	ON
WALK DISABLE	OFF
LOG CVM FAULTS	ON
EXTERN WATCHDOG	OFF
24V-2=12VDC	OFF
PGM CARD MEMORY	ON
LEDguard	ON
FORCE TYPE 16	OFF
TYPE12-SDLC	OFF
VM 3xDay Latch	ON

ECONOLITE EOS-2070 SPECIAL MMU PROGRAMMING

(program controller as shown)

- From Main Menu select 1. CONFIGURATION
- From CONFIGURATION Submenu select 1. CABINET
- From PORT 1 (SDLC) Submenu select 4. MONITOR PROGRAMMING

CAUTION!

Set intersection to Flash before attempting to enter or change any MMU programming data.

This programming and that of the MMU programming card must match exactly. If they do not, the intersection will be placed into Flash.

```

MMU PROGRAM [  MANUAL ]

CH  6 5 4 3 2 1 0 9 8 7 6 5 4 3 2
1  . X . X . . . . . X X . .
2  . X . X . . . . . X X . .
3  . . . . .
4  . . . . .
5  . X . X . . . . .
6  . X . X . . . . .
7  . . . . .
8  . . . . .
9  . . . . .
10 . . . . .
11 . . . . .
12 . . . . .
13 . X .
14 . .
15 .
                    
```

END PROGRAMMING

DETECTOR RACK SETUP

INSERT DETECTOR CARDS IN RACK ACCORDING TO THE DETAIL SHOWN BELOW. PARTICULAR DETECTOR CHANNELS WILL CALL PHASES INDICATED.

DET BIU #1	CH3	CH1	CH3	CH1	CH3	CH1	CH3	CH1	S	S	S	S	DET BIU #2
L3	L1	L7	L5	L11	L9	L15	L13		S	S	S	S	
Ø1	Ø1	Ø2	Ø2	Ø5	Ø5	Ø6	Ø6		E	E	E	E	
13	11	23	21	53	51	63	61		M	M	M	M	
CH4	CH2	CH4	CH2	CH4	CH2	CH4	CH2						
L4	L2	L8	L6	L12	L10	L16	L14						
Ø1	Ø1	Ø2	Ø2	Ø5	Ø5	Ø6	Ø6						
14	12	24	22	54	52	64	62						

APS PUSH BUTTON INPUT SETUP

W-5710AK JOB NO.	D.J.W. PREPARED BY	03-2022 DATE	
01904 SIGNAL NO.	10-2403 NCDOT ID NO.	L. MOON APPROVER	

NC 16 (BROOKSHIRE BLVD)
@ OLD PLANK RD

SIGNAL DETAILS

CITY OF CHARLOTTE
DEPARTMENT OF
TRANSPORTATION
600 E. 4TH ST. 1ST FLOOR, CHARLOTTE, NC 28202
704.359.4195 FAX: 704.359.4660

Plans Prepared By: DRMP, Inc.
8000 Regency Parkway, Suite 110
Charlotte, NC 28226
NC License No. C-22516 (919) 659-1038

REVISION DESCRIPTION

NO.	DATE	BY

North Carolina Professional Engineer
Seal 022516
L. MOON

Designed by: Lisa M. Moon /25/2022
DOCUMENT NOT CONSIDERED FINAL UNLESS ALL SIGNATURES COMPLETED

SHEET SIG2.2 OF SIG2.6

LEGEND

○ EXISTING SPLICE
● NEW SPLICE

ALL UNUSED FIBERS ARE TO BE EXPRESSED THROUGH.

SPLICE 01904

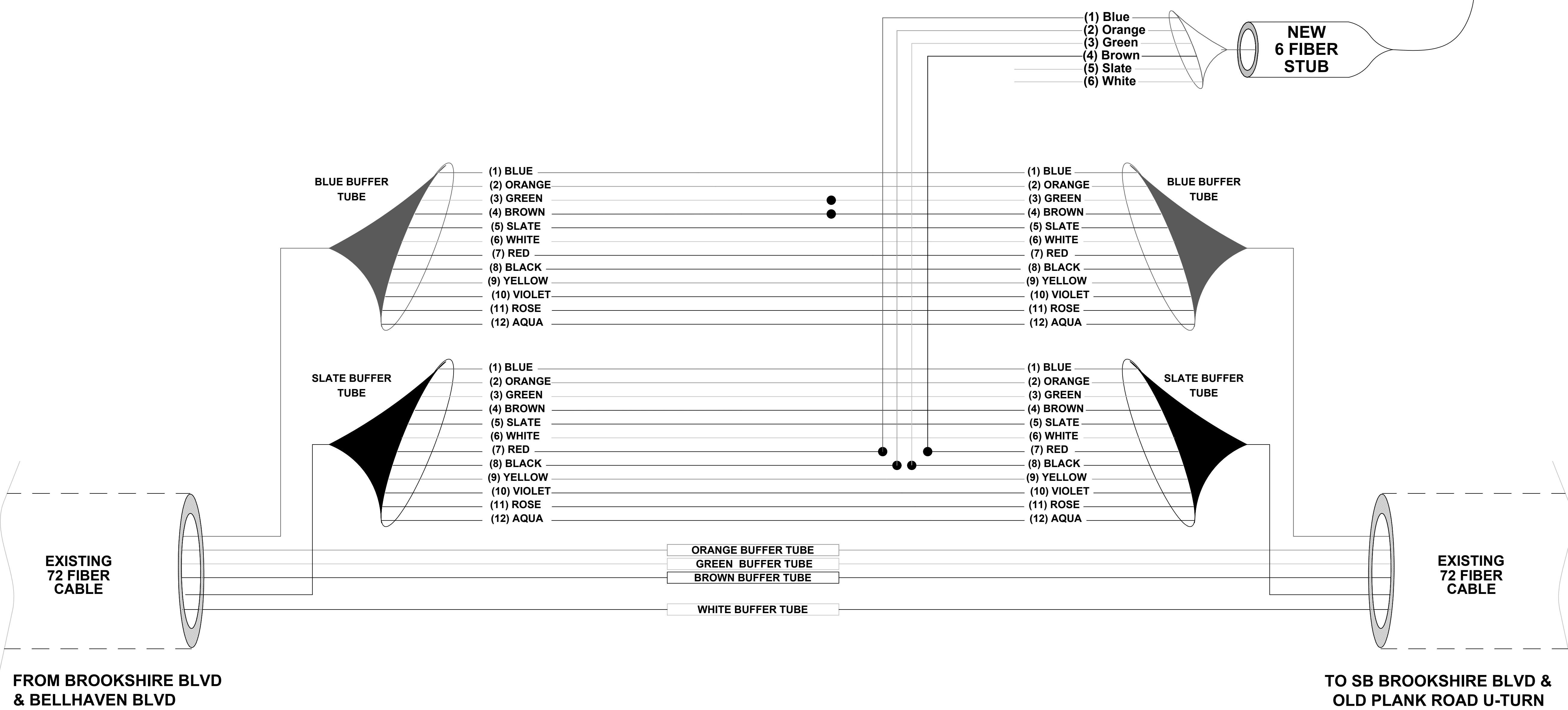
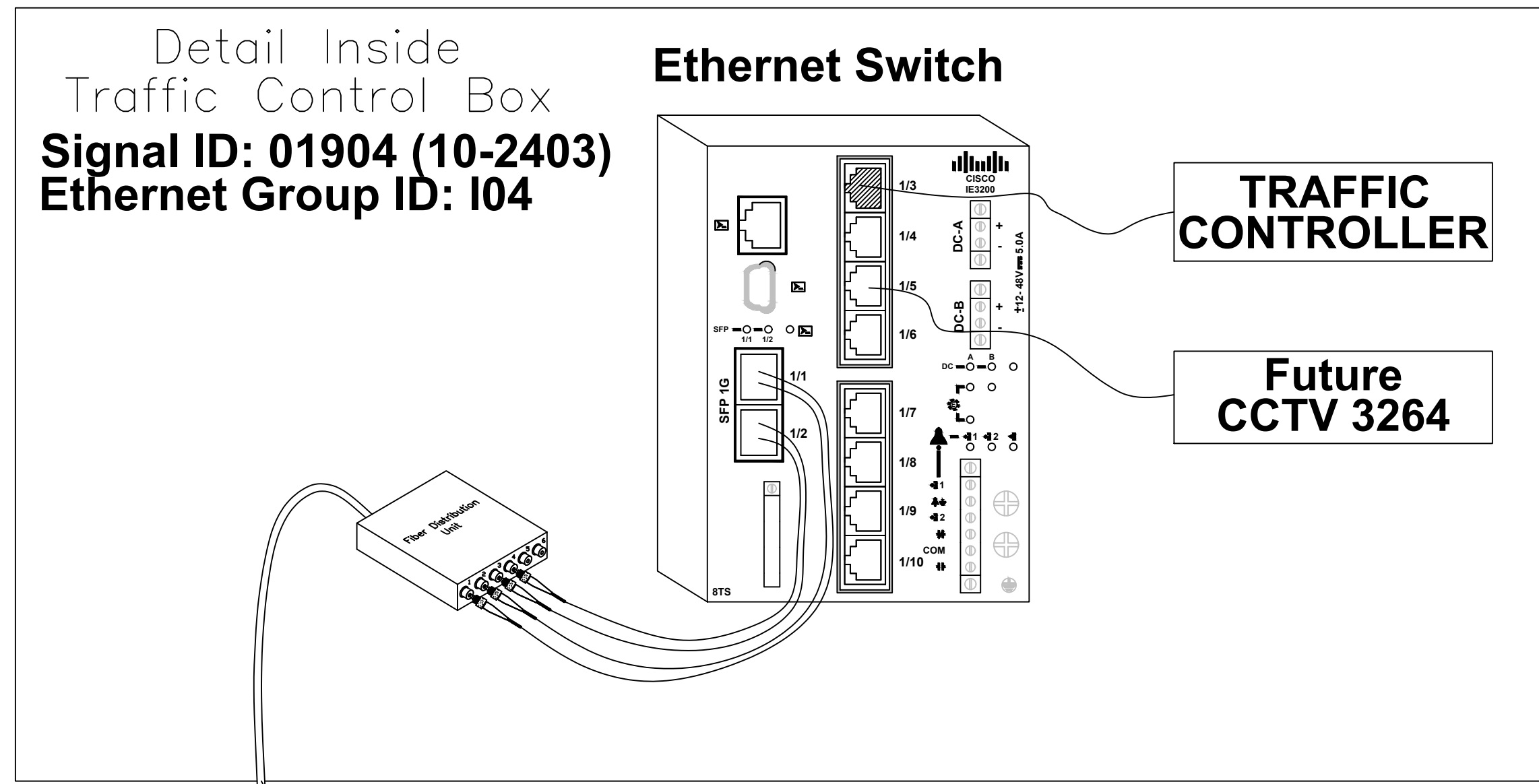

SPLICE CASE IN EX. HANDHOLE# 13 ON SB BROOKSHIRE BLVD AT ~300' NORTH OF OLD PLANK ROAD



Plans Prepared For:
CITY OF CHARLOTTE
DEPARTMENT OF TRANSPORTATION
600 E. 4TH ST. 1ST FLOOR, CHARLOTTE, NC 28202
704.255-4191 FAX: 704.336-4660

Plans Prepared By:
DRMP
DRMP, Inc.
8000 Regency Parkway, Suite 110
Charlotte, NC 28226 (919) 659-1038
NC License No. C-2216 (919) 659-4660

NO.	DATE	BY	REVISION DESCRIPTION

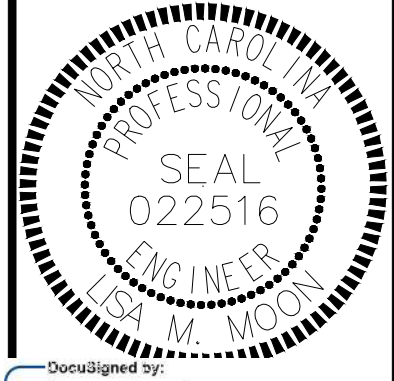

Designed by: *Lisa M. Moon* 3/25/2022
SCE56808300421

DOCUMENT NOT CONSIDERED FINAL UNLESS ALL SIGNATURES COMPLETED

W-5710AK JOB NO.	DJW PREPARED BY	03-2022 DATE
01904 SIGNAL NO.	10-2403 NCDOT ID NO.	L. MOON APPROVER

NC 16 (BROOKSHIRE BLVD) @ OLD PLANK RD

FIBER OPTIC SPLICE DETAILS

SHEET **SIG2.3** OF **SIG2.6**

SIGNAL HEAD WIRING

CHANNEL		SIGNAL HEAD HOOK UP CHART																																			
PHASE		1				2		3		4		5				6		7		8		9		10		11		12		13		14		15		16	
SIGNAL HEAD NO.		11★	12★	14	13	15	22	21	NU	NU	51★	52★	54	53	55	61	62	NU	NU	NU	NU	NU	NU	NU	NU	NU	11a★	12a★	NU	51a★	52a★	NU					
RED	Wire			14R	13R	15R	22R	21R					54R	53R	55R	61R	62R																				
	Terminal			LS1-R	[14R]	LS1-R	LS2-R	[22R]					LS5-R	[54R]	LS5-R	LS6-R	[61R]																				
YELLOW	Wire	*	*								*	*																									
	Terminal						LS2-Y	[22Y]								LS6-Y	[61Y]																				
GREEN	Wire						22G	21G								61G	62G																				
	Terminal						LS2-G	[22G]								LS6-G	[61G]																				
RED ARROW	Wire																									11RS	12RS		51RS	52RS							
	Terminal																									LS13-R	LS13-R		LS15-R	LS15-R							
YELLOW ARROW	Wire			14YS	13YS	15YS							54YS	53YS	55YS											11YS	12YS		51YS	52YS							
	Terminal			LS1-Y	[14Y]	LS1-Y							LS5-Y	[54Y]	LS5-Y											LS13-Y	LS13-Y		LS15-Y	LS15-Y							
FLASHING YELLOW	Wire																									11Y	12Y		51Y	52Y							
	Terminal																									LS13-G	LS13-G		LS15-G	LS15-G							
GREEN ARROW	Wire	11GS	12GS	14GS	13GS	15GS					51GS	52GS	54GS	53GS	55GS																						
	Terminal	LS1-G	LS1-G	LS1-G	[14G]	LS1-G					LS5-G	LS5-G	LS5-G	[54G]	LS5-G																						

[XX*] = TERMINAL BLOCK IN SIGNAL HEAD | LSX* = TERMINAL IN LOAD BAY * Denotes install load resistor. See Load Resistor Detail on this sheet. See pictorial of head wiring detail on this sheet, NU = NOT USED

Plans Prepared For:
CITY OF CHARLOTTE
 DEPARTMENT OF TRANSPORTATION
 600 E. 4TH ST. 1ST FLOOR, NC 28202
 704.359.4119 FAX: 704.359.4600

Plans Prepared By:
DRMP
 DRMP, Inc.
 8000 Regency Parkway, Suite 110
 Cary, NC 27513
 NC License No. C-2219 (P) 919.656-1088

NO.	DATE	BY	REVISION DESCRIPTION

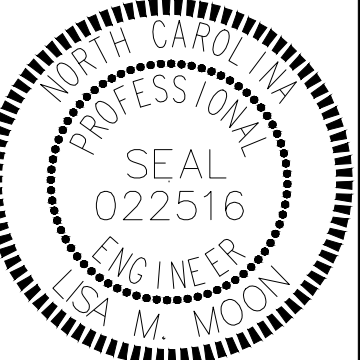

Disseminated by: *Lisa M. Moon* 3/25/2022
 54658808020421
 DOCUMENT NOT CONSIDERED FINAL UNLESS ALL SIGNATURES COMPLETED

W-5710AK	JOB NO.	DJW	PREPARED BY	03-2022	DATE
01904	SIGNAL NO.	10-2403	NCDOT ID NO.	L. MOON	APPROVER

SHEET **SIG2.4** OF **SIG2.6**

NC 16 (BROOKSHIRE BLVD) @ OLD PLANK RD

SIGNAL WIRING DIAGRAM

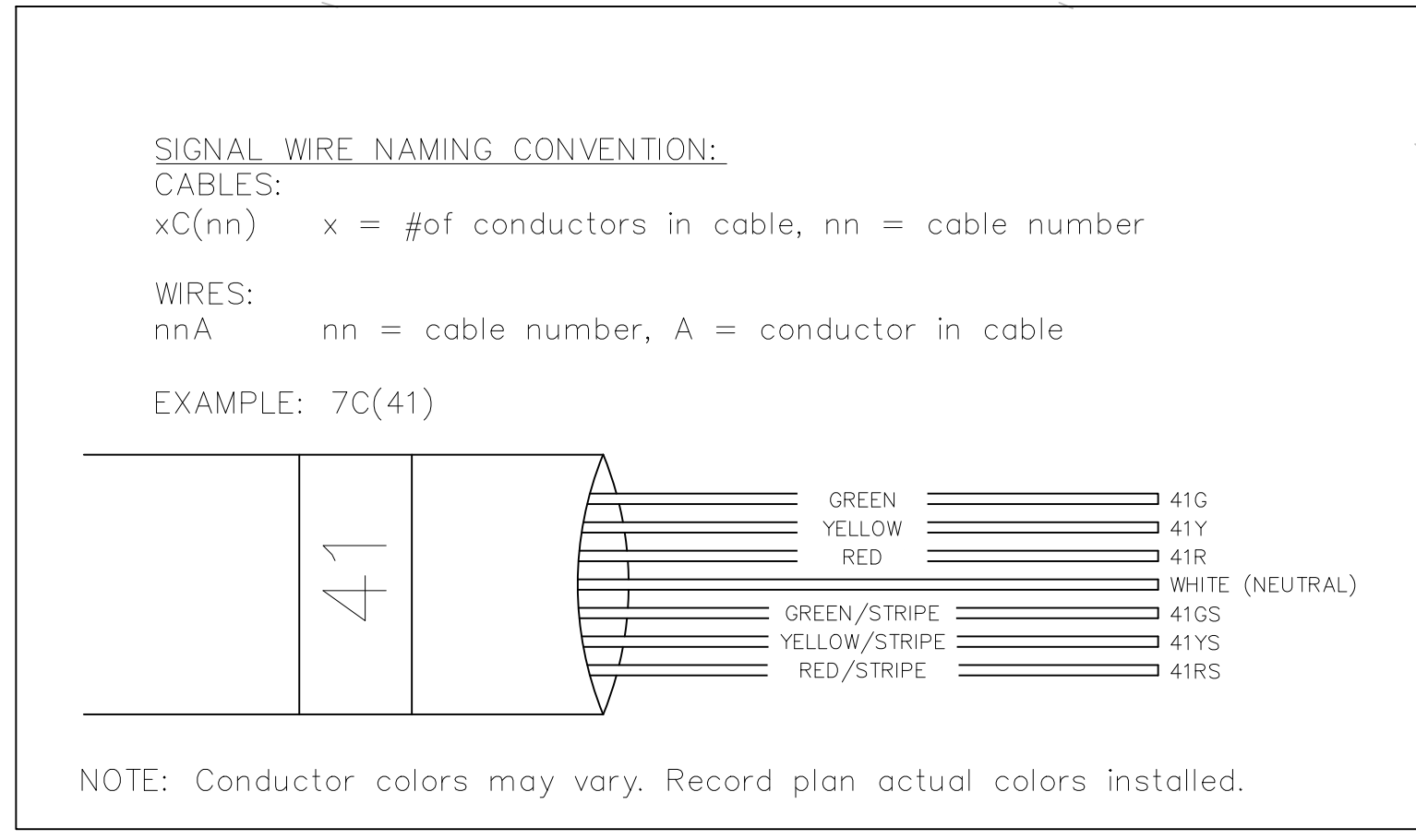
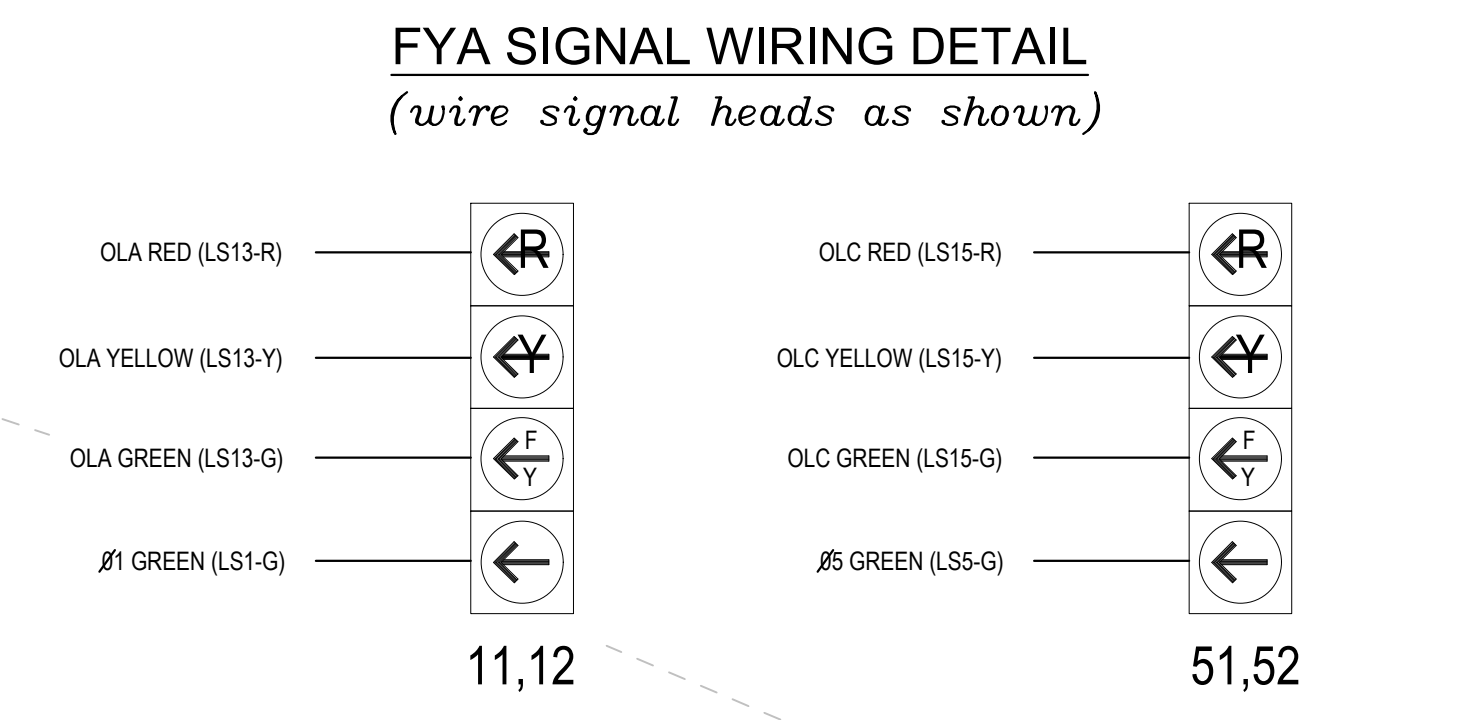
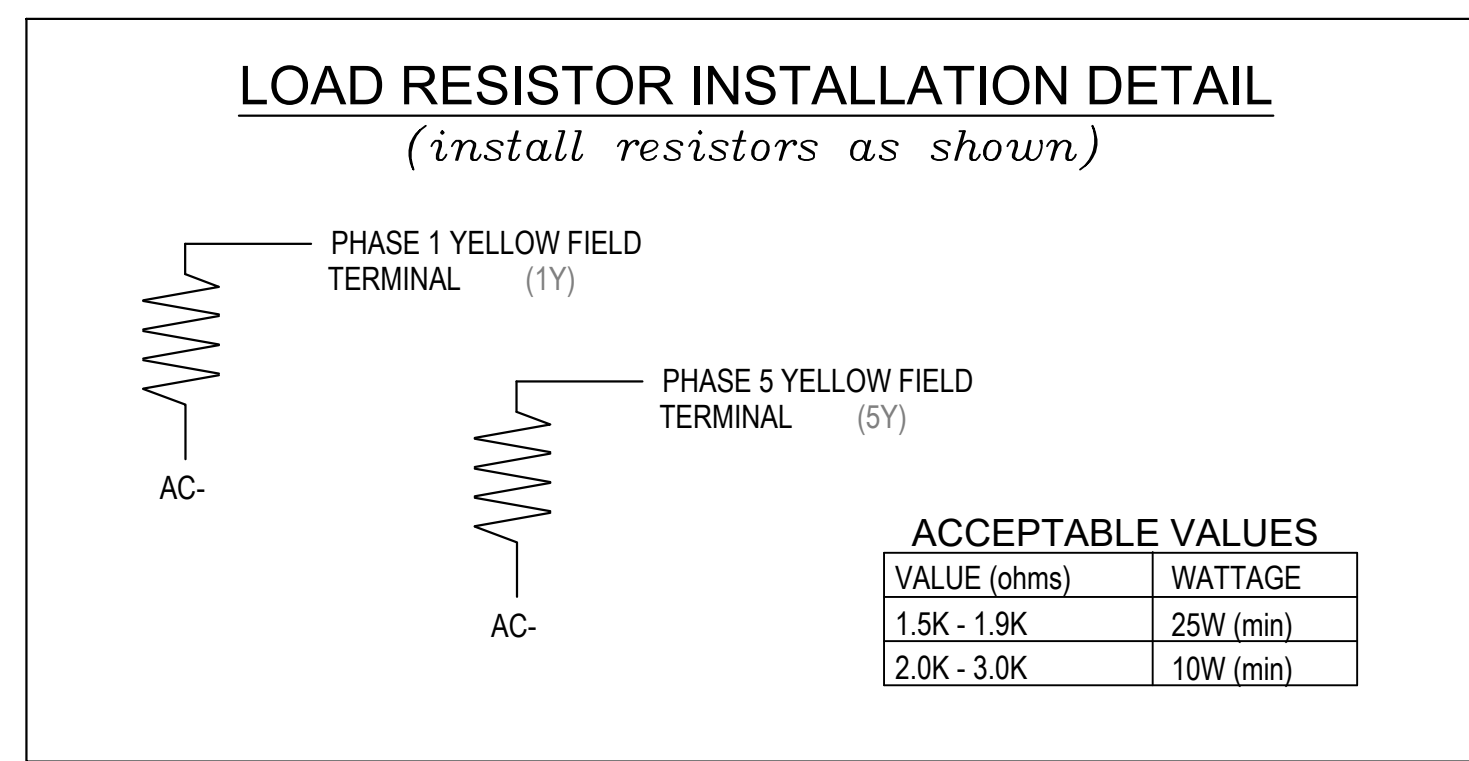
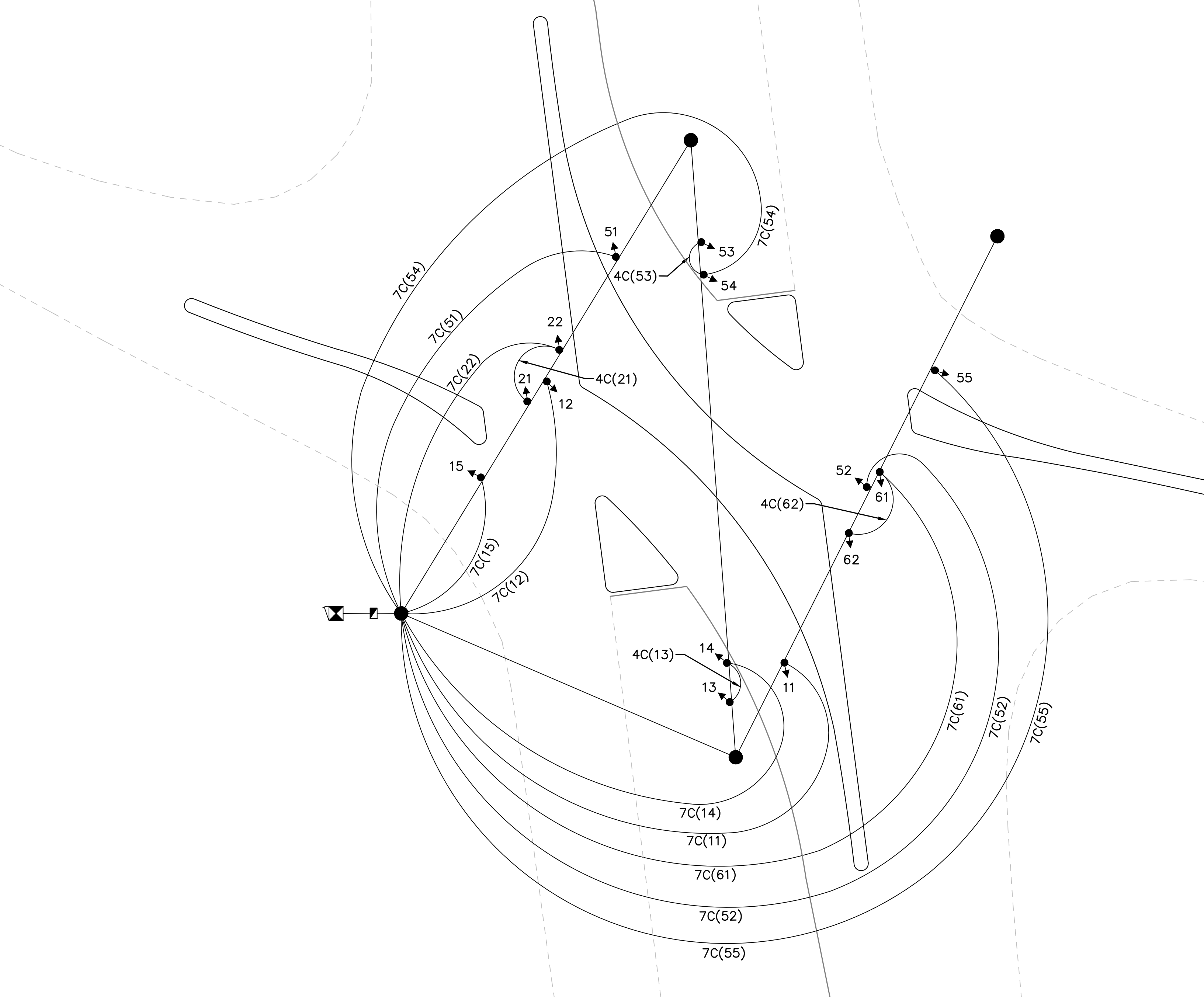

NOTE: Conductor colors may vary. Record plan actual colors installed.

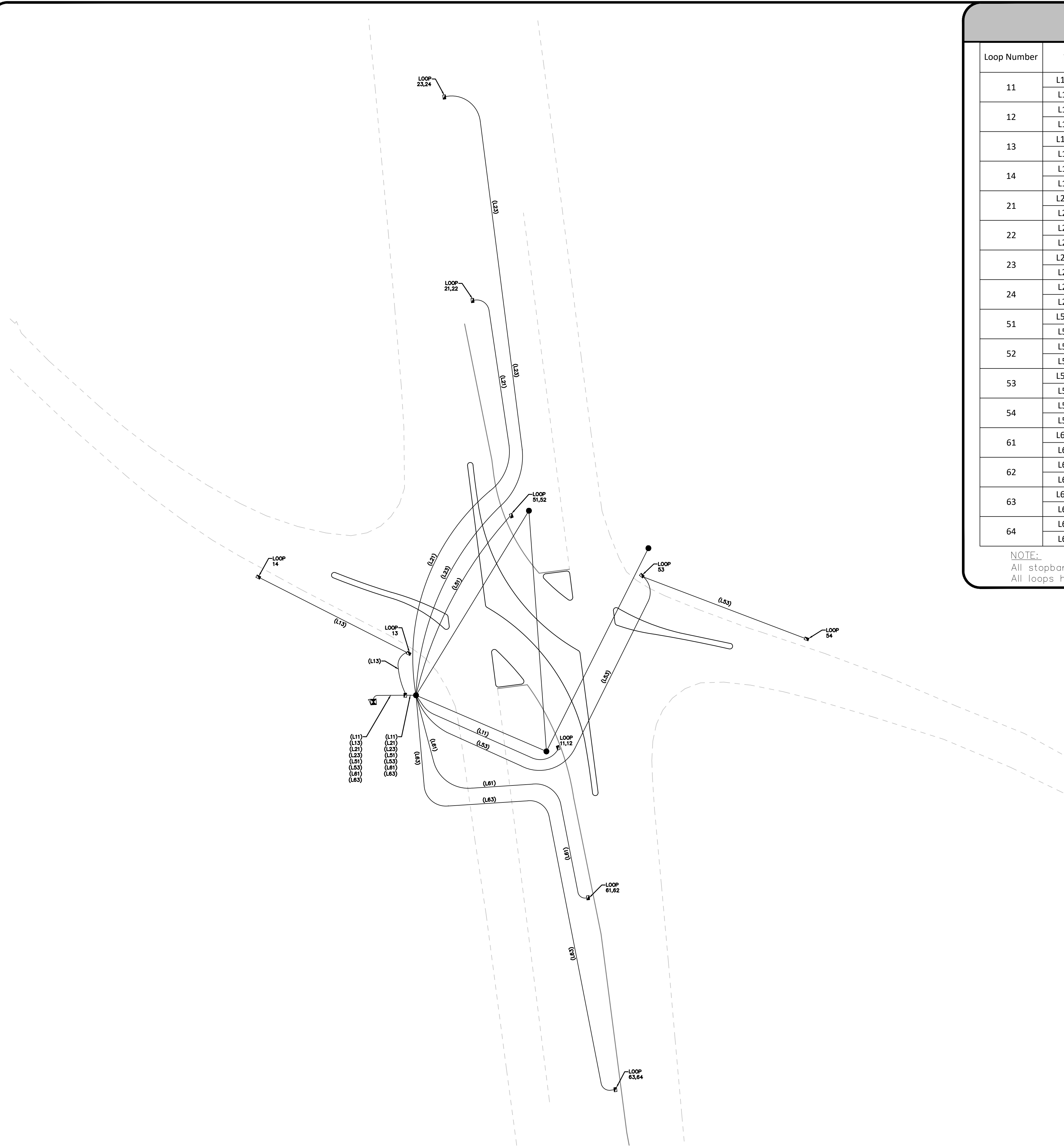

LOOP WIRING

Loop Number	Wire	Terminal	Controller Detector Number	Phase	Timing		Size	Comments
					Feature	Time (sec)		
11	L11-1-W	LT1-1	1	1	-	-	6'X25'	@ STOP BAR
	L11-1-B	LT1-2						
12	L11-2-R	LT1-3	2	1	-	-	6'X25'	65' FROM STOP BAR
	L11-2-B	LT1-4						
13	L13-1-W	LT1-5	3	1	DELAY	15	6'X25'	@STOP BAR
	L13-1-B	LT1-6						
14	L13-2-R	LT1-7	4	1	-	-	6'X6'	130' FROM STOP BAR
	L13-2-B	LT1-8						
21	L21-1-W	LT1-9	5	2	-	-	6'X6'	130' FROM STOP BAR
	L21-1-B	LT1-10						
22	L21-2-R	LT1-11	6	2	-	-	6'X6'	130' FROM STOP BAR
	L21-2-B	LT1-12						
23	L23-1-W	LT1-13	7	2	-	-	6'X6'	280' FROM STOP BAR
	L23-1-B	LT1-14						
24	L23-2-R	LT1-15	8	2	-	-	6'X6'	280' FROM STOP BAR
	L23-2-B	LT1-16						
51	L51-1-W	LT2-1	9	5	-	-	6'X25'	@ STOP BAR
	L51-1-B	LT2-2						
52	L51-2-R	LT2-3	10	5	-	-	6'X25'	65' FROM STOP BAR
	L51-2-B	LT2-4						
53	L53-1-W	LT2-5	11	5	DELAY	15	6'X25'	@STOP BAR
	L53-1-B	LT2-6						
54	L53-2-R	LT2-7	12	5	-	-	6'X25'	130' FROM STOP BAR
	L53-2-B	LT2-8						
61	L61-1-W	LT2-9	13	6	-	-	6'X6'	130' FROM STOP BAR
	L61-1-B	LT2-10						
62	L61-2-R	LT2-11	14	6	-	-	6'X6'	130' FROM STOP BAR
	L61-2-B	LT2-12						
63	L63-1-W	LT2-13	15	6	-	-	6'X6'	280' FROM STOP BAR
	L63-1-B	LT2-14						
64	L63-2-R	LT2-15	16	6	-	-	6'X6'	280' FROM STOP BAR
	L63-2-B	LT2-16						

NOTE:
 All stopbar loops are 5' beyond the stopbar unless otherwise noted.
 All loops have 3 turns.

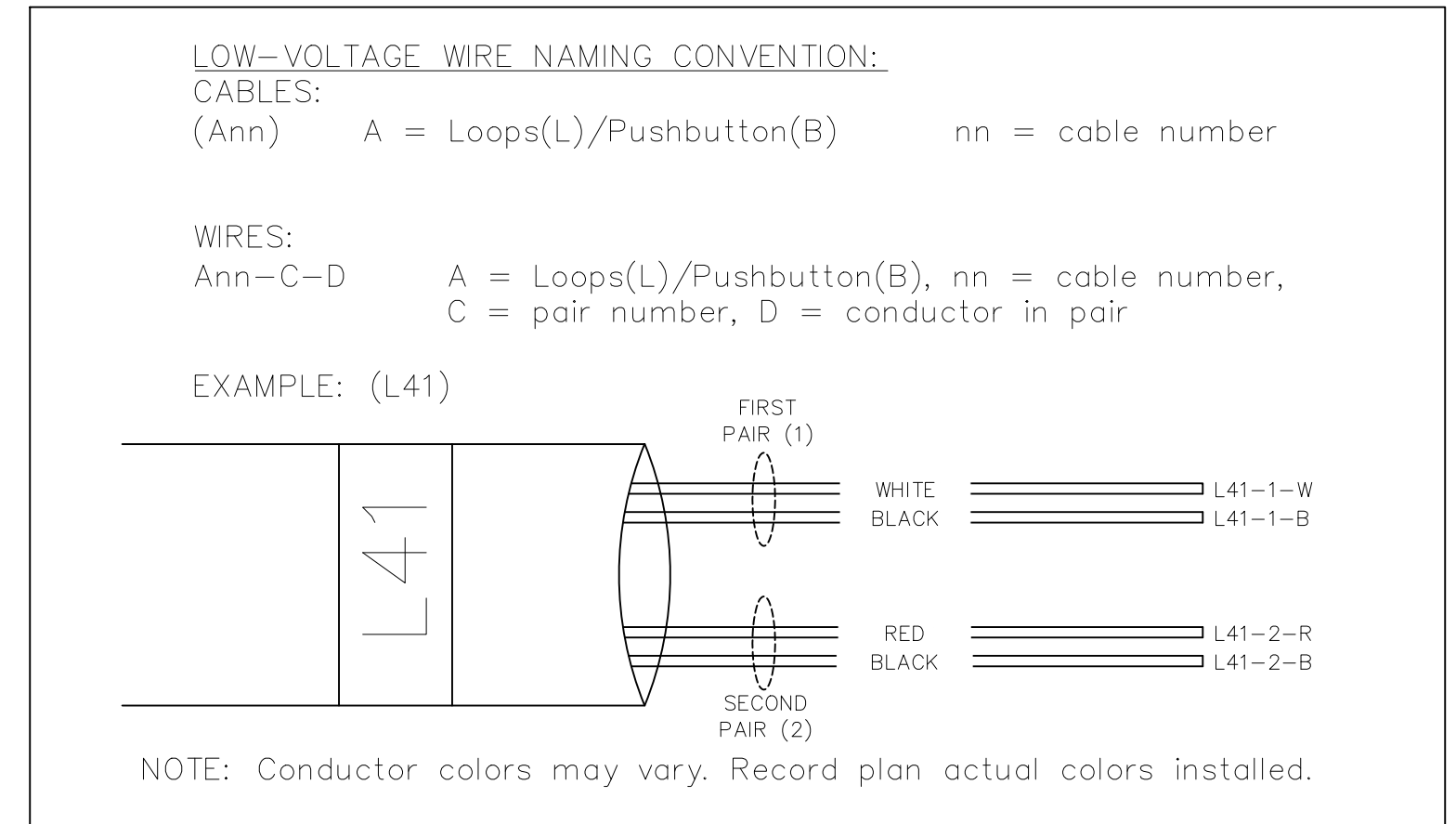

NOTE

CDOT TO PROGRAM DETECTOR
 TYPES AND TIMERS (EXTEND AND
 DELAY) AS SHOWN IN LOOP WIRING
 CHART ABOVE INTO CONTROLLER

NOTE:
 ALL LEAD-IN WIRE SHOULD BE TWO PAIR CABLE



Plans Prepared For:
CITY OF CHARLOTTE
 DEPARTMENT OF
 TRANSPORTATION
 600 E. 4TH STREET, FLOOR 10, NC 28202
 704.259.4191 FAX: 704.336.4660

Plans Prepared By:

DRMP, Inc.
 8000 Regency Parkway, Suite 110
 Cary, NC 27513
 NC License No. C-2216 (919) 659-1038

NO.	DATE	BY	REVISION DESCRIPTION

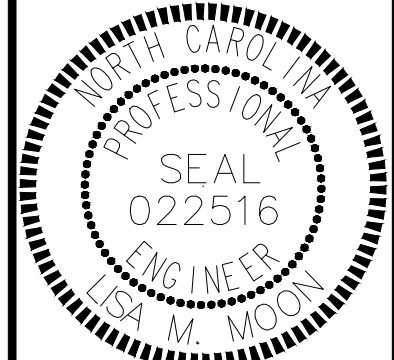

Designed by
Lisa M. Moon
 3/25/2022
 DOCUMENT NOT CONSIDERED FINAL
 UNLESS ALL SIGNATURES COMPLETED

W-5710AK JOB NO.	DJW PREPARED BY	03-2022 DATE
01904 SIGNAL NO.	10-2403 NCDOT ID NO.	L. MOON APPROVER

**NC 16 (BROOKSHIRE BLVD)
 @ OLD PLANK RD**

**LOW VOLTAGE
 WIRING DIAGRAM**

SHEET
SIG2.5
 OF
SIG2.6

NOTES

1. To prevent "flash-conflict" problems, wire all unused load switches to flash red. Verify that signal heads flash in accordance with the signal plans.
2. To prevent red failures on unused monitor channels, tie unused load switch red outputs 3, 4, 7, 8, 9, 10, 11, 12, 14, and 16 to load switch AC+ by inserting a jumper plug in the unused load switch socket from pin 1 (LS AC+) to pin 3 (RED out). Make sure all flash transfer relays are in place.
- ◆ 3. Program controller to start up in phase 2 Green and 6 Green.
- ◆ 4. Set power-up flash time to 12 seconds and implement on the Malfunction Management Unit. Set controller power-up flash time to 22 seconds.
- ◆ 5. Program detectors in accordance with the manufacturer's instructions to accomplish the detection schemes shown on the signal design plans.
- ◆ 6. Program detector call delay and extension timing on the controller, unless otherwise specified.
7. Set all detector card unit channels to "presence" mode.
8. The cabinet and controller are a part of the Charlotte Signal System.

◆ Software and Programming by CDOT

City of Charlotte Department of Transportation (CDOT) to provide EOS Software and do all Programming of the controller database. Contractor to provide CDOT with controller for programming a minimum of two weeks prior to installation. CDOT will return controller, fully programmed for contractor to install and integrate into the controller cabinet.

EQUIPMENT INFORMATION

CONTROLLER.....2070LX
 CABINET[TS-2]
 SOFTWAREECONOLITE EOS-2070
 CABINET MOUNT.....BASE
 LOADBAY POSITIONS.....16
 LOAD SWITCHES USED.....1,2,5,6,13,15
 PHASES USED.....1,2,5,6
 OLA.....1+2
 OLB.....NOT USED
 OLC.....5+6
 OLD.....NOT USED



Plans Prepared For:
 CITY OF CHARLOTTE
 DEPARTMENT OF
 TRANSPORTATION
 600 E. 4TH ST. CHARLOTTE, NC 28202
 704.359.4191 FAX: 704.359.4660

Plans Prepared By:

 DRMP, Inc.
 8000 Regency Parkway, Suite 110
 Cary, NC 27513
 NC License No. C-22516 (919) 659-1038

NO.	DATE	BY	REVISION DESCRIPTION



Designed by
Lisa M. Moon /25/2022

DOCUMENT NOT CONSIDERED FINAL UNLESS ALL SIGNATURES COMPLETED

W-5710AK JOB NO.	DJM PREPARED BY	03-2022 DATE
---------------------	--------------------	-----------------

01904 SIGNAL NO.	10-2403 NCDOT ID NO.	L. MOON APPROVER
---------------------	-------------------------	---------------------

NC 16 (BROOKSHIRE BLVD)
 @ OLD PLANK RD
 MISCELLANEOUS
 DETAILS

SHEET
SIG2.6
 OF
SIG2.6

Signal ID 01905 / NCDOT 10-2402

NC 16 (Brookshire Blvd) SB @ Old Plank Rd U-Turn

INDEX OF SHEETS	
Cover Sheet	SIG3.0
Signal Plan	SIG3.1
Signal Details	SIG3.2
Splice Detail	SIG3.3
Signal Wiring Diagram	SIG3.4
Low Voltage Wiring Diagram	SIG3.5
Miscellaneous Details	SIG3.6
TOTAL SHEETS 7	

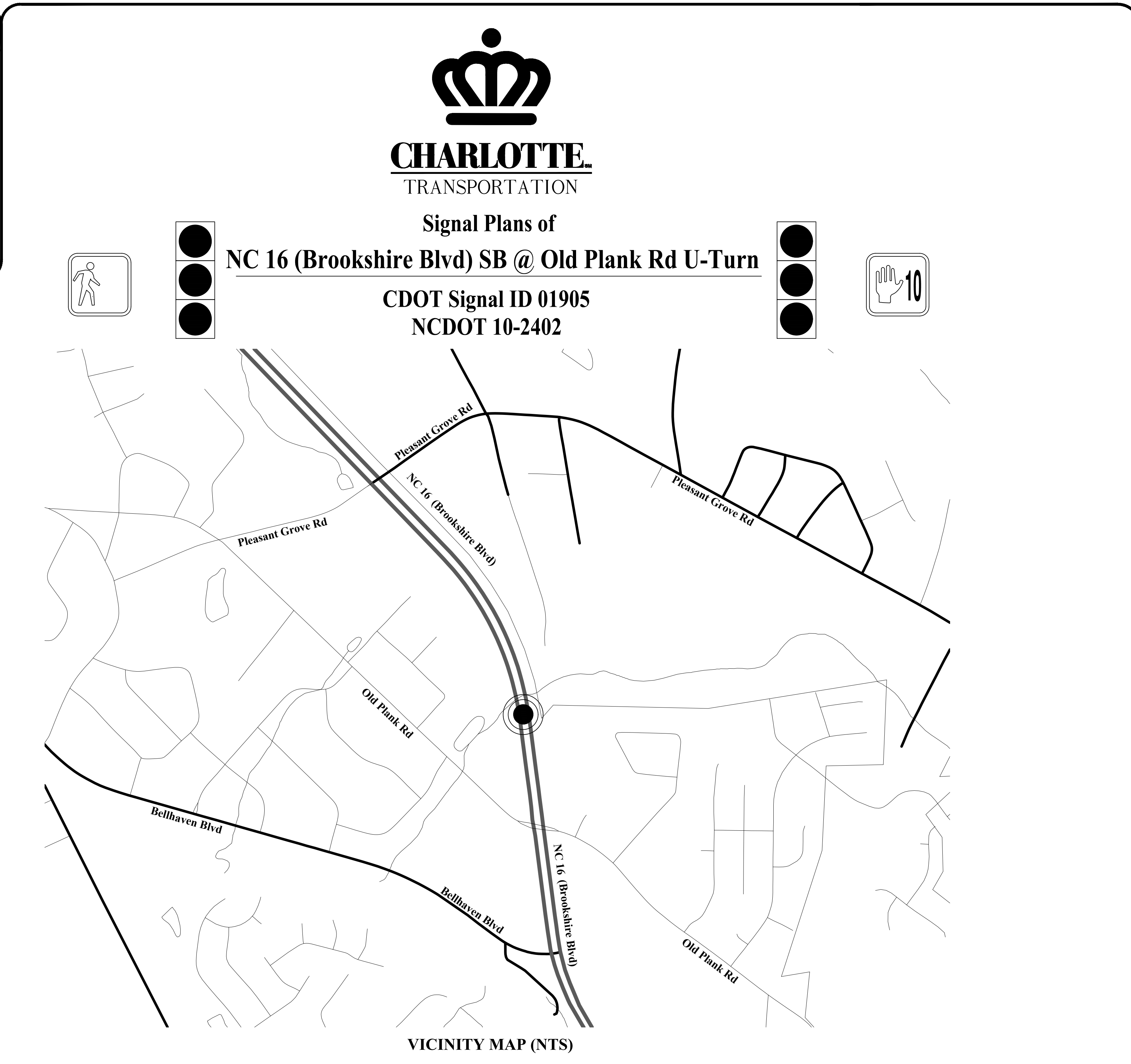

LEGEND		
PROPOSED	DESCRIPTION	EXISTING
	CONTROL BOX	
	METER PEDESTAL	
	PULL BOX	
	STEEL POLE	
	MAST ARM	
	PED PEDESTAL	
	UTILITY POLE	
	ANCHOR	
	SIGNAL HEAD	
	VIDEO CAMERA	
	OPTICOM	
	OBSERVATION CAM	
	DETECTOR	
	CONDUIT	
	INTERCONNECT	
	EDGE OF PVMT.	
	CURB & GUTTER	
	TUBULAR MARKER	
	GROUND SIGN	
	OVERHEAD SIGN	
	DOUBLE YELLOW	
	STOP BAR	
	WHITE SKIP	
	WHITE MINI	
	PAVEMENT ARROW	
	PROPERTY LINE	
	ROW	
	UTILITIES TELEPHONE UG CABLE SUE	
	UTILITIES SANITARY SEWER UG LINE	
	UTILITIES WATER UG LINE SUE	
	UTILITIES GAS UG LINE SUE	
	UTILITIES TELEPHONE UG FO SUE	
	OTHER CULTURE FENCE LINE	

PULLBOX ID		
	SIZE	PULLBOX TYPE
①	13"x24"x12"	LOOP
②	17"x30"x30"	FIBER OPTIC
③	24"x36"x24"	CONTROLLER / FIBER
④	30"x48"x36"	CONTROLLER
⑤	24"x24"x12"	CONTROLLER
UH-2	24"x36"x30"	FIBER SPLICE

NOTE:
PULLBOX MATERIAL MUST MEET OR EXCEED THE 2018 NCDOT STANDARD TRAFFIC SIGNAL SPECIFICATIONS.

PLANS PREPARED FOR:

City of Charlotte
Department of Transportation
 600 East 4th Street Charlotte, NC 28202
 Phone: (704) 336-4119
 Fax: (704) 336-4400

- PLAN NOTES**
- ALL PAVEMENT MARKING DIMENSIONS ARE APPROXIMATE.
 - SIGNAL SHALL BE INSTALLED IN ACCORDANCE WITH THE LATEST NCDOT STANDARD SPECIFICATIONS AND PROJECT SPECIAL PROVISIONS.
 - CITY WILL SUPPLY STREET NAME SIGNS FOR INSTALLATION.
 - SEE SIGNAL COMMUNICATION PLANS FOR CONSTRUCTION RELATED TO SYSTEM, SHOWN ON SIGNAL PLANS AS EXISTING.
 - ATTACHMENT HEIGHTS ARE ESTIMATED, BASED ON AVAILABLE INFORMATION AND EXISTING SURVEY ELEVATIONS. CONTRACTOR SHALL FIELD VERIFY ELEVATIONS TO ENSURE POLES OF SUFFICIENT LENGTH TO MAINTAIN MINIMUM REQUIRED CLEARANCE ABOVE THE ROADWAY.

PE SEAL

DESIGNED BY: Lisa M. Moon 3/25/2022
 DOCUMENT NOT CONSIDERED FINAL UNLESS ALL SIGNATURES COMPLETED

PROJECT TEAM

Plans Prepared By:	DESIGNER:	D. White
DRMP	PROJECT ENGINEER:	C. Silver
DRMP, Inc. 8000 Regency Parkway, Suite 110 Cary, NC 27518 NC License No. C-2213 (919) 650-1038	PROJECT MANAGER:	L. Moon

Prepared for the Offices of:

750 N. Greenfield Pkwy,
Garner, NC 27529

SHEET
SIG3.0

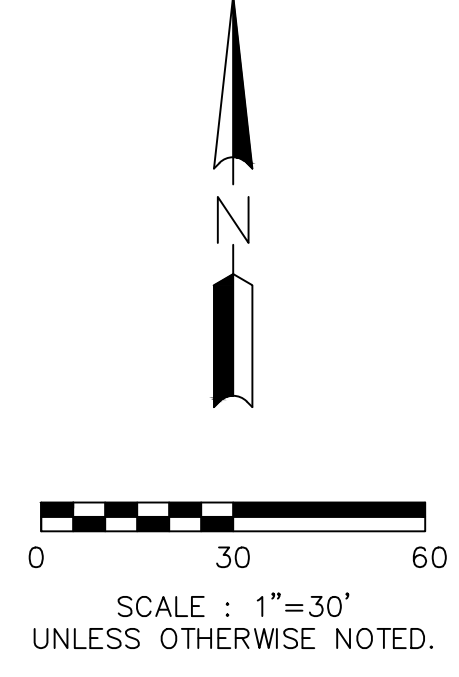
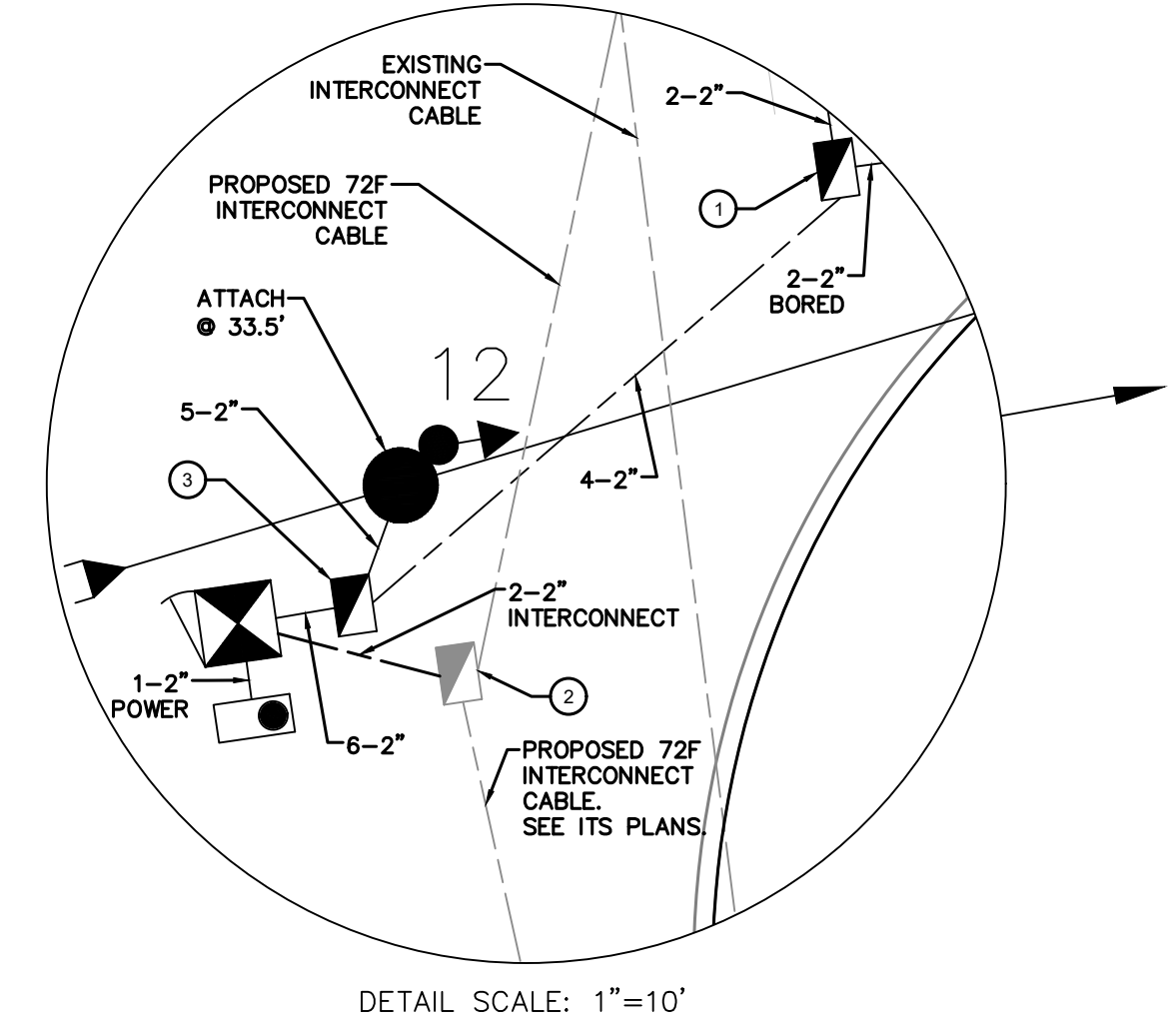
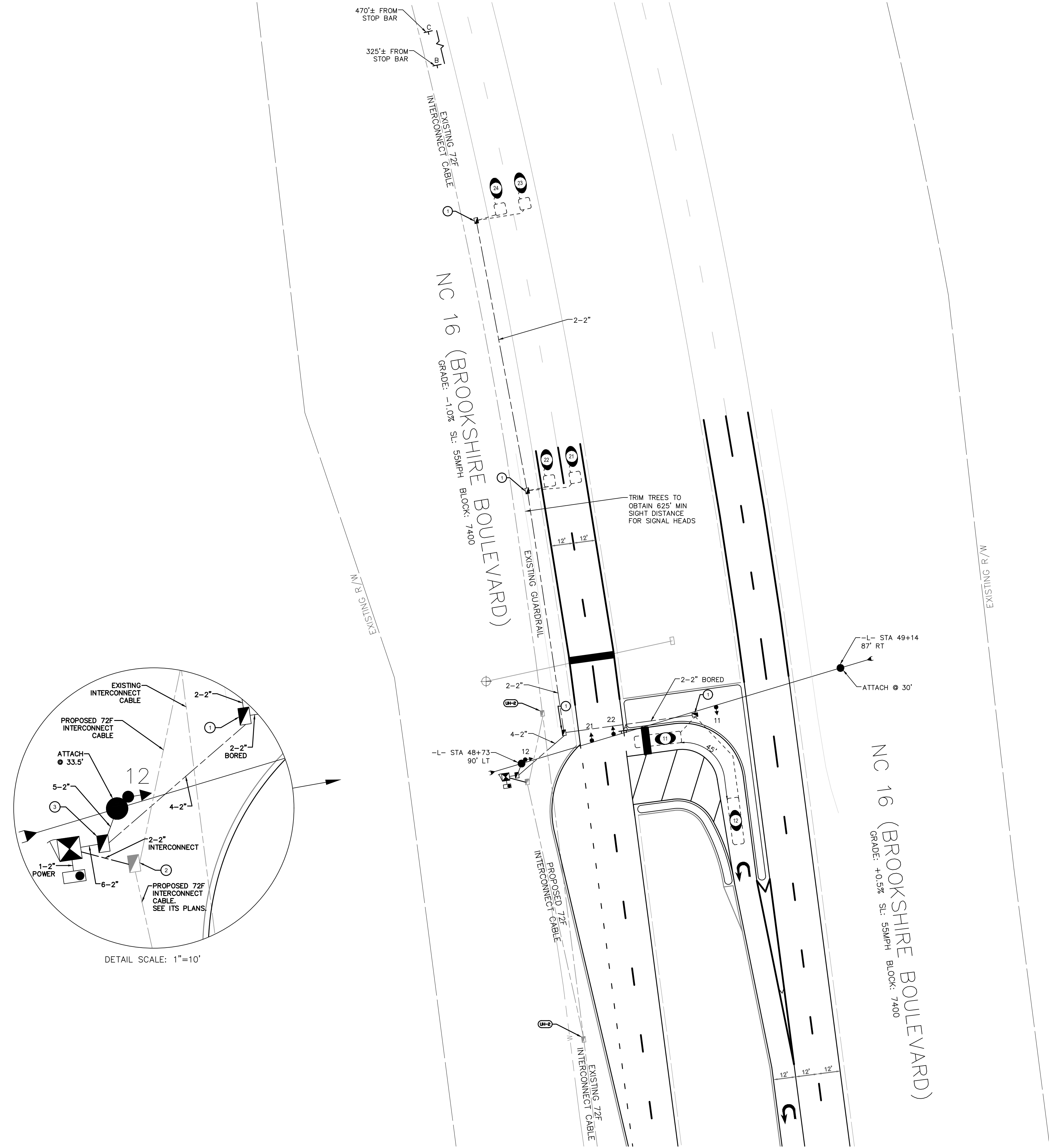

Plans Prepared For:
CITY OF CHARLOTTE
 DEPARTMENT OF
 TRANSPORTATION
 600 E. 4TH STREET, CHARLOTTE, NC 28202
 704.255-4119 FAX: 704.336-4660

Plans Prepared By:
DRMP
 DRMP, Inc.
 8000 Regency Parkway, Suite 110
 Cary, NC 27513
 (919) 659-1038
 NC License No. C-2216

NO.	DATE	BY	REVISION DESCRIPTION



Designed by: *Lisa M. Moon* 3/25/2022
 THIS DOCUMENT IS PRELIMINARY AND NOT FOR CONSTRUCTION.
 THIS DOCUMENT IS NOT CONSIDERED FINAL UNLESS ALL SIGNATURES ARE COMPLETED.

W-5710AK JOB NO.	DJW PREPARED BY	03-2022 DATE
01905 SIGNAL NO.	10-2402 NCDOT ID NO.	L. MOON APPROVER

NC 16 (BROOKSHIRE BLVD) SB @ OLD PLANK RD U-TURN

SHEET **SIG3.1** OF **SIG3.6**
SIGNAL PLAN

SIGNAL PHASING

Ring Configuration 1,2,3,4,5,6,7,8

MIN RECALL

1 NOT USED

2 NOT USED

3 NOT USED

4 NOT USED

5 NOT USED

6 NOT USED

7 NOT USED

8 NOT USED

SIGNAL SEQUENCE

RING 1	PHASE 1	PHASE 2	PHASE 3	PHASE 4	FLASH				
SIGNAL ID NUMBER	R/W	OTH	R/W	OTH	R/W	OTH	R/W	OTH	FLASH
11,12			G	Y					
21,22									

RING 2	PHASE 5	PHASE 6	PHASE 7	PHASE 8	FLASH				
SIGNAL ID NUMBER	R/W	OTH	R/W	OTH	R/W	OTH	R/W	OTH	FLASH

OVERLAP PHASE

OVERLAP PHASE	OL-A/	OL-B/	OL-C/	OL-D/	FLASH				
SIGNAL ID NUMBER	R/W	OTH	R/W	OTH	R/W	OTH	R/W	OTH	FLASH

OVERLAP PHASE	OL-E/	OL-F/	OL-G/	OL-H/	FLASH				
SIGNAL ID NUMBER	R/W	OTH	R/W	OTH	R/W	OTH	R/W	OTH	FLASH

◀ RED ARROW ◀ YELLOW ARROW
 ▶ GREEN ARROW ✱ FLASHING YELLOW ARROW

TURNING MOVEMENT COUNT

NOT AVAILABLE

SIGN ID

A R3-2 36" x 36"

B W3-3 36" x 36"

C W3-4 36" x 36"

CLEARANCE INTERVALS

Phase	1	2	3	4	5	6	7	8
% Grade	0.5%	-1.0%						
Distance	61	81						
Approach Speed (mph)	15	55						
Yellow	3.0	5.3						
All Red	2.8	1.1						
Total Clearance	5.8	6.4						

SIGNAL HEAD ID

21,22

11

12

MALFUNCTION MANAGEMENT UNIT / CONFLICT MONITOR

PROGRAMMING DETAIL

(program card and tables as shown)

FIELD CHECK ENABLE
 DUAL IND ENABLE
 RED FAIL ENABLE

CHANNEL NUMBER	ENABLE/DISABLE
1	ENABLE
2	ENABLE
3	DISABLE
4	DISABLE
5	DISABLE
6	DISABLE
7	DISABLE
8	DISABLE
9	DISABLE
10	DISABLE
11	DISABLE
12	DISABLE
13	DISABLE
14	DISABLE
15	DISABLE
16	DISABLE

CAUTION!
 Set intersection to Flash before attempting to enter or change any MMU programming data.
 This programming and that of the MMU programming card must match exactly. If they do not, the intersection will be placed into Flash.

ECONOLITE EOS-2070 SPECIAL MMU PROGRAMMING

(program controller as shown)

- From Main Menu select 1. CONFIGURATION
- From CONFIGURATION Submenu select 1. CABINET
- From PORT 1 (SDLC) Submenu select 4. MONITOR PROGRAMMING

```

MMU PROGRAM [ MANUAL ]

CH  6 5 4 3 2 1 0 9 8 7 6 5 4 3 2
1  . . . . .
2  . . . . .
3  . . . . .
4  . . . . .
5  . . . . .
6  . . . . .
7  . . . . .
8  . . . . .
9  . . . . .
10 . . . . .
11 . . . . .
12 . . . . .
13 . . . . .
14 . . . . .
15 . . . . .
    
```

END PROGRAMMING

OPTION	SETTING
RECURRENT PULSE	ON
WALK DISABLE	OFF
LOG CVM FAULTS	ON
EXTERN WATCHDOG	OFF
24V-2-12VDC	OFF
PGM CARD MEMORY	ON
LEDguard	ON
FORCE TYPE 16	OFF
TYPE12-SDLC	OFF
VM 3xDay Latch	ON

CONFIG MODE	B
ENABLE CHANNEL PAIR, FYA	
CH 1-13	OFF
CH 3-14	OFF
CH 5-15	OFF
CH 7-16	OFF
RED/YEL INPUT ENABLE	
CH 1	OFF
CH 3	OFF
CH 5	OFF
CH 7	OFF
FLASH RATE FAULT	ON
FYA TRAP DETECT	ON

MMU PROGRAMMING NOTE
 ENSURE YELLOW CHANGE PLUS RED CLEARANCE MONITORING IS ENABLED FOR ALL CHANNELS.

DETECTOR RACK SETUP

INSERT DETECTOR CARDS IN RACK ACCORDING TO THE DETAIL SHOWN BELOW. PARTICULAR DETECTOR CHANNELS WILL CALL PHASES INDICATED.

DET BIU #1	CH3	CH1	CH3	CH1	S	S	S	S	S	S	DET BIU #2
L3	L1	L7	L5								
Ø 2	Ø 1	NOT USED	Ø 2								
21	11		23								
CH4	CH2	CH4	CH2								
L4	L2	L8	L6								
Ø 2	Ø 1	NOT USED	Ø 2								
22	12		24								

APS PUSH BUTTON INPUT SETUP

W-5710AK	JOB NO.	DJW	PREPARED BY	03-2022	DATE

01905	SIGNAL NO.	10-2402	NC DOT ID NO.	L. MOON	APPROVER

NC 16 (BROOKSHIRE BLVD) SB @ OLD PLANK RD U-TURN

SIGNAL DETAILS

SHEET SIG3.2 OF SIG3.6

Plans Prepared For: CITY OF CHARLOTTE DEPARTMENT OF TRANSPORTATION 600 E. 4TH ST. 2ND FLOOR, CHARLOTTE, NC 28202 704.259.4191 FAX: 704.336.4660

Plans Prepared By: DRMP, Inc. 8000 Regency Parkway, Suite 110 Charlotte, NC 28226 (919) 659-1038 NC License No. C-2216

REVISION DESCRIPTION

NO. BY DATE

DESIGNED BY: Lisa M. Moon 3/25/2022

SEAL 022516 ENGINEER LISA M. MOON

LEGEND
 ○ EXISTING SPLICE
 ● NEW SPLICE
 ALL UNUSED FIBERS ARE TO BE EXPRESSED THROUGH.

SPLICE 01905

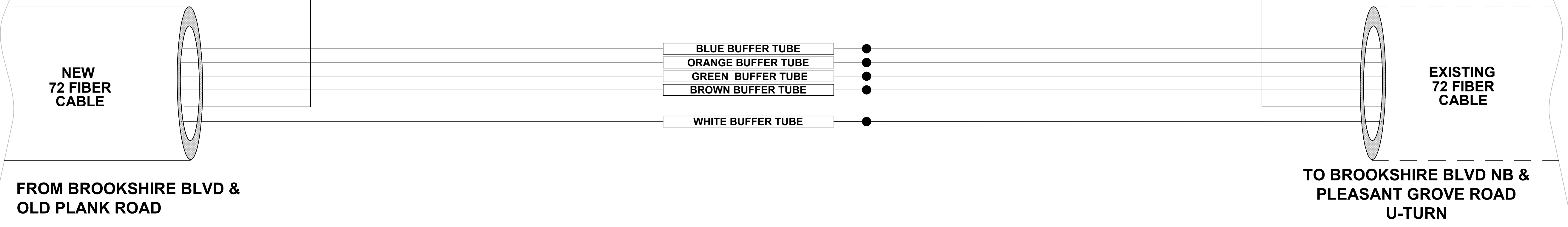
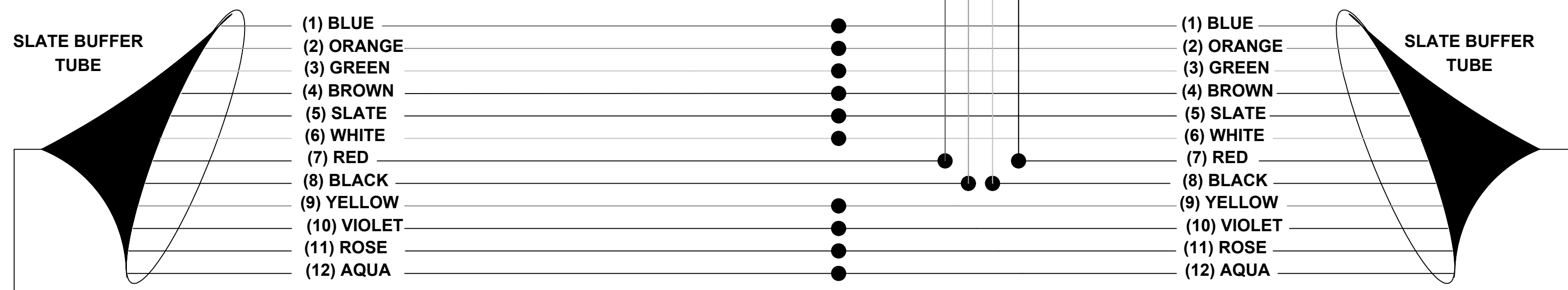
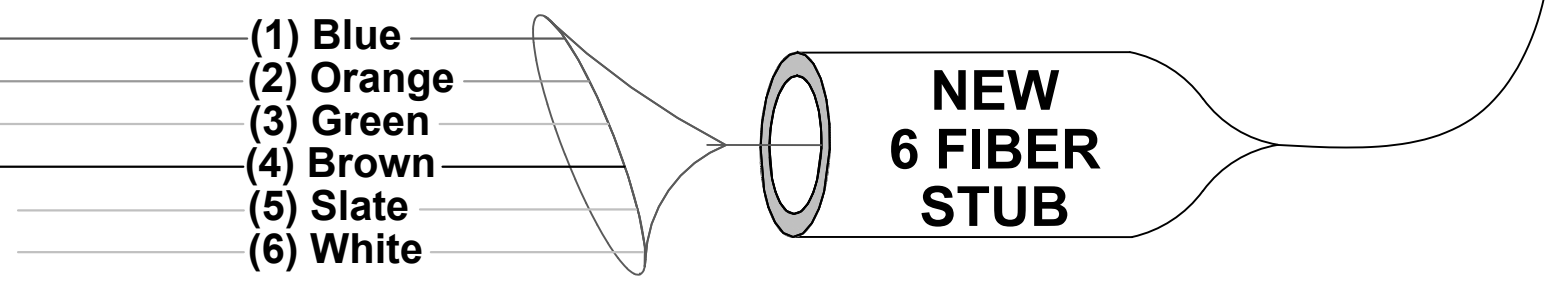
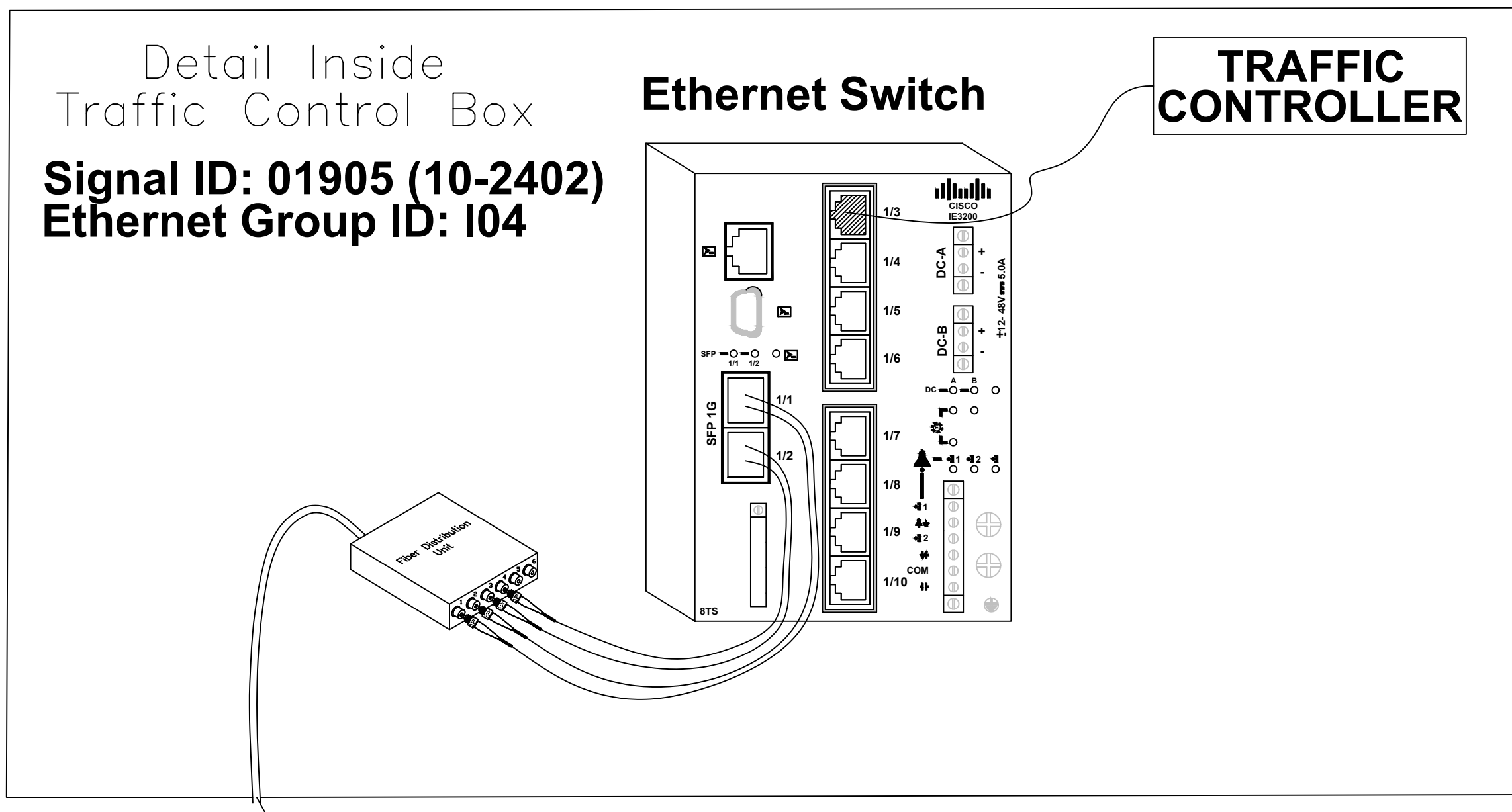

SPLICE CASE IN EX HANDHOLE# 13.3 ON SB BROOKSHIRE BLVD AT OLD PLANK ROAD U-TURN



Plans Prepared For:
CITY OF CHARLOTTE
 DEPARTMENT OF TRANSPORTATION
 600 E. 4TH ST. CHARLOTTE, NC 28202
 704.259.4191 FAX: 704.336.4660

Plans Prepared By:
DRMP
 DRMP, Inc.
 8000 Regency Parkway, Suite 110
 Cary, NC 27513
 NC License No. C-2216 (919) 659-1038

NO.	DATE	BY	REVISION DESCRIPTION



Designed by
Lisa M. Moon /25/2022
 SCS-ES68BDS100421

DOCUMENT NOT CONSIDERED FINAL UNLESS ALL SIGNATURES COMPLETED

W-5710AK JOB NO.	DJW PREPARED BY	03-2022 DATE
01905 SIGNAL NO.	10-2402 NCDOT ID NO.	L. MOON APPROVER

NC 16 (BROOKSHIRE BLVD) SB @ OLD PLANK RD U-TURN

FIBER OPTIC SPLICE DETAILS

SHEET SIG3.3 OF SIG3.6

SIGNAL HEAD WIRING

		SIGNAL HEAD HOOK UP CHART															
CHANNEL		1	2	3	4	5	6	7	8	9	10	11	12	13	14	15	16
PHASE		1	2	3	4	5	6	7	8	2 PED	4 PED	6 PED	8 PED	OL-A	OL-B	OL-C	OL-D
SIGNAL HEAD NO.		11	12	22	21	NU	NU	NU	NU	NU	NU	NU	NU	NU	NU	NU	NU
RED	Wire			22R	21R												
	Terminal			LS2-R	[22R]												
YELLOW	Wire			22Y	21Y												
	Terminal			LS2-Y	[22Y]												
GREEN	Wire			22G	21G												
	Terminal			LS2-G	[22G]												
RED ARROW	Wire	11RS	12RS														
	Terminal	LS1-R	LS1-R														
YELLOW ARROW	Wire	11YS	12YS														
	Terminal	LS1-Y	LS1-Y														
FLASHING YELLOW	Wire																
	Terminal																
GREEN ARROW	Wire	11GS	12GS														
	Terminal	LS1-G	LS1-G														

[XX*] = TERMINAL BLOCK IN SIGNAL HEAD | LSX* = TERMINAL IN LOAD BAY | NU = NOT USED

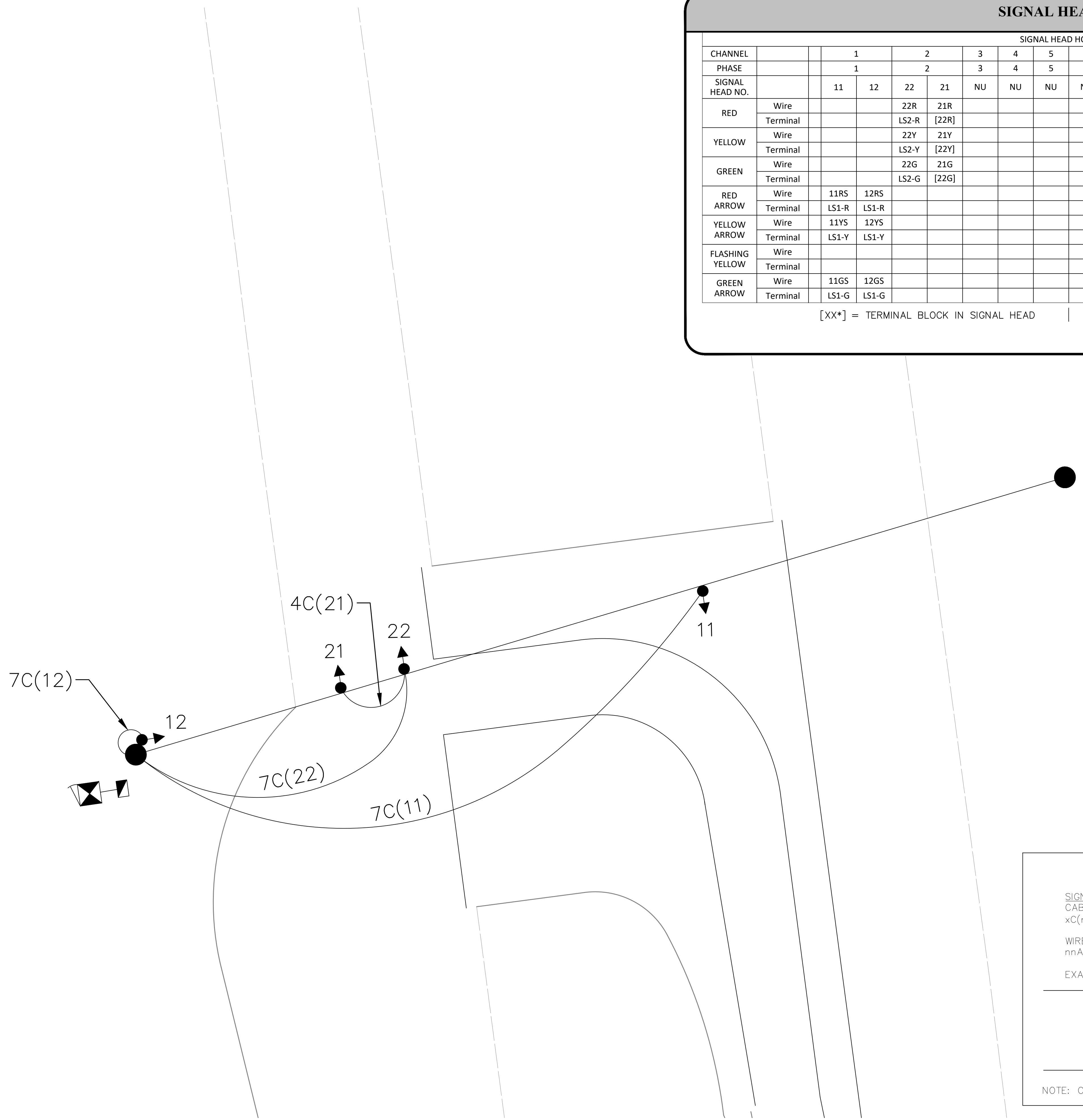

SIGNAL WIRE NAMING CONVENTION:
CABLES:
 xC(nn) x = #of conductors in cable, nn = cable number
WIRES:
 nnA nn = cable number, A = conductor in cable
EXAMPLE: 7C(41)

GREEN	41G
YELLOW	41Y
RED	41R
WHITE	WHITE (NEUTRAL)
GREEN/STRIPE	41GS
YELLOW/STRIPE	41YS
RED/STRIPE	41RS

NOTE: Conductor colors may vary. Record plan actual colors installed.



Plans Prepared For:
CITY OF CHARLOTTE
 DEPARTMENT OF
 TRANSPORTATION
 600 E. 4TH ST. CHARLOTTE, NC 28202
 PH: 352-410-1111 FAX: 704-358-4660

Plans Prepared By:
DRMP
 DRMP, Inc.
 8000 Regency Parkway, Suite 110
 Cary, NC 27513
 NC License No. C-22-16 (919) 659-1038

NO.	DATE	BY	REVISION DESCRIPTION



Designed by
Lisa M. Moon /25/2022
 16C6580R0200421

DOCUMENT NOT CONSIDERED FINAL UNLESS ALL SIGNATURES COMPLETED

01905	W-5710AK
SIGNAL NO.	JOB NO.
10-2402	DJM
NC DOT ID NO.	PREPARED BY
L. MOON	03-2022
APPROVER	DATE

NC 16 (BROOKSHIRE BLVD) SB @ OLD PLANK RD U-TURN

SHEET **SIG3.4** OF **SIG3.6**
SIGNAL WIRING DIAGRAM

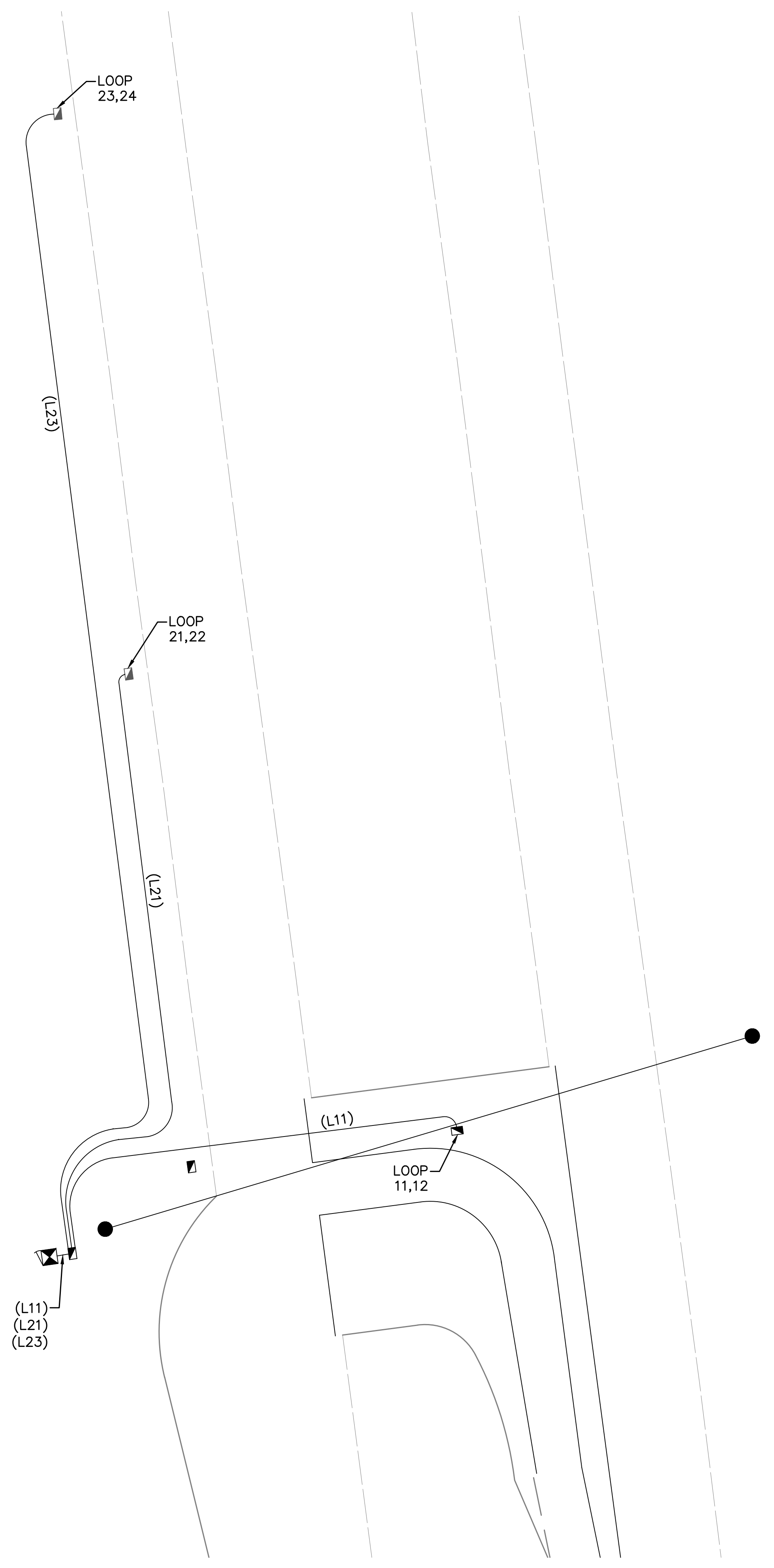

LOOP WIRING

Loop Number	Wire	Terminal	Controller Detector Number	Phase	Timing		Size	Comments
					Feature	Time (sec)		
11	L11-1-W	LT1-1	1	1	-	-	6'X25'	@ STOP BAR
	L11-1-B	LT1-2						
12	L11-2-R	LT1-3	2	1	-	-	6'X25'	65' FROM STOP BAR
	L11-2-B	LT1-4						
21	L21-1-W	LT1-5	3	2	-	-	6'X6'	130' FROM STOP BAR
	L21-1-B	LT1-6						
22	L21-2-R	LT1-7	4	2	-	-	6'X6'	130' FROM STOP BAR
	L21-2-B	LT1-8						
23	L23-1-W	LT1-9	5	2	-	-	6'X6'	280' FROM STOP BAR
	L23-1-B	LT1-10						
24	L23-2-R	LT1-11	6	2	-	-	6'X6'	280' FROM STOP BAR
	L23-2-B	LT1-12						

NOTE:
All stopbar loops are 5' beyond the stopbar unless otherwise noted.
All loops have 3 turns.

LOW-VOLTAGE WIRE NAMING CONVENTION:

CABLES:
(Ann) A = Loops(L)/Pushbutton(B) nn = cable number

WIRES:
Ann-C-D A = Loops(L)/Pushbutton(B), nn = cable number,
C = pair number, D = conductor in pair

EXAMPLE: (L41)

NOTE: Conductor colors may vary. Record plan actual colors installed.

NOTE

CDOT TO PROGRAM DETECTOR
TYPES AND TIMERS (EXTEND AND
DELAY) AS SHOWN IN LOOP WIRING
CHART ABOVE INTO CONTROLLER



Plans Prepared For:
CITY OF CHARLOTTE
DEPARTMENT OF
TRANSPORTATION
600 E. 4TH ST. CHARLOTTE, NC 28202
704.259.4119 FAX: 704.336.4660

Plans Prepared By:
DRMP
DRMP, Inc.
8000 Regency Parkway, Suite 110
Charlotte, NC 28226
NC License No. C-2216 (919) 659-1038

NO.	DATE	BY	REVISION DESCRIPTION

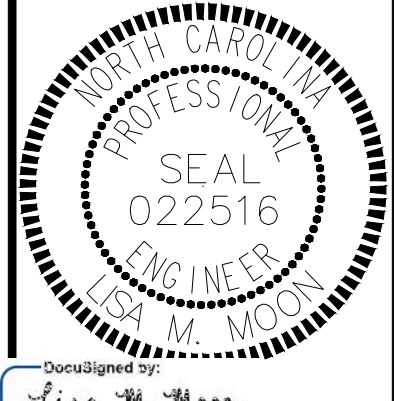

Designed by:
Lisa M. Moon 3/25/2022
SIC568BDS00421

DOCUMENT NOT CONSIDERED FINAL UNLESS ALL SIGNATURES COMPLETED

W-5710AK JOB NO.	DJM PREPARED BY	03-2022 DATE
01905 SIGNAL NO.	10-2402 NCDOT ID NO.	L. MOON APPROVER

NC 16 (BROOKSHIRE BLVD) SB
@ OLD PLANK RD U-TURN

**LOW VOLTAGE
WIRING DIAGRAM**

SHEET
SIG3.5
OF
SIG3.6

NOTE:
ALL LEAD-IN WIRE SHOULD BE TWO PAIR CABLE

NOTES

1. To prevent "flash-conflict" problems, wire all unused load switches to flash red. Verify that signal heads flash in accordance with the signal plans.
2. To prevent red failures on unused monitor channels, tie unused load switch red outputs 3, 4, 5, 6, 7, 8, 9, 10, 11, 12, 13, 14, 15 and 16 to load switch AC+ by inserting a jumper plug in the unused load switch socket from pin 1 (LS AC+) to pin 3 (RED out). Make sure all flash transfer relays are in place.
- ◆ 3. Program controller to start up in phase 2 Green.
- ◆ 4. Set power-up flash time to 12 seconds and implement on the Malfunction Management Unit. Set controller power-up flash time to 22 seconds.
- ◆ 5. Program detectors in accordance with the manufacturer's instructions to accomplish the detection schemes shown on the signal design plans.
- ◆ 6. Program detector call delay and extension timing on the controller, unless otherwise specified.
7. Set all detector card unit channels to "presence" mode.
8. The cabinet and controller are a part of the Charlotte Signal System.

EQUIPMENT INFORMATION

CONTROLLER.....2070LX
 CABINET[TS-2]
 SOFTWAREECONOLITE EOS-2070
 CABINET MOUNT.....BASE
 LOADBAY POSITIONS.....16
 LOAD SWITCHES USED.....1,2
 PHASES USED.....1,2
 OLA.....NOT USED
 OLB.....NOT USED
 OLC.....NOT USED
 OLD.....NOT USED

◆ Software and Programming by CDOT

City of Charlotte Department of Transportation (CDOT) to provide EOS Software and do all Programming of the controller database. Contractor to provide CDOT with controller for programming a minimum of two weeks prior to installation. CDOT will return controller, fully programmed for contractor to install and integrate into the controller cabinet.



Plans Prepared For:
 CITY OF CHARLOTTE
 DEPARTMENT OF
 TRANSPORTATION
 600 E. 4TH ST. CHARLOTTE, NC 28202
 704.359.4119 FAX: 704.359.4660

Plans Prepared By:

 DRMP, Inc.
 8000 Regency Parkway, Suite 110
 Cary, NC 27513
 NC License No. C-2216 (919) 659-1038

NO.	DATE	BY	REVISION DESCRIPTION



Designed by: *Lisa M. Moon* 3/25/2022

DOCUMENT NOT CONSIDERED FINAL UNLESS ALL SIGNATURES COMPLETED

W-5710AK JOB NO.	DJM PREPARED BY	03-2022 DATE
01905 SIGNAL NO.	10-2402 NCDOT ID NO.	L. MOON APPROVER

NC 16 (BROOKSHIRE BLVD) SB
 @ OLD PLANK RD U-TURN
**MISCELLANEOUS
 DETAILS**

SHEET
SIG3.6
 OF
SIG3.6

Signal ID 01906 / NCDOT 10-2401

NC 16 (Brookshire Blvd) NB @ Pleasant Grove Rd U-Turn

INDEX OF SHEETS	
Cover Sheet	SIG4.0
Signal Plan	SIG4.1
Signal Details	SIG4.2
Splice Detail	SIG4.3
Signal Wiring Diagram	SIG4.4
Low Voltage Wiring Diagram	SIG4.5
Miscellaneous Details	SIG4.6
TOTAL SHEETS 7	

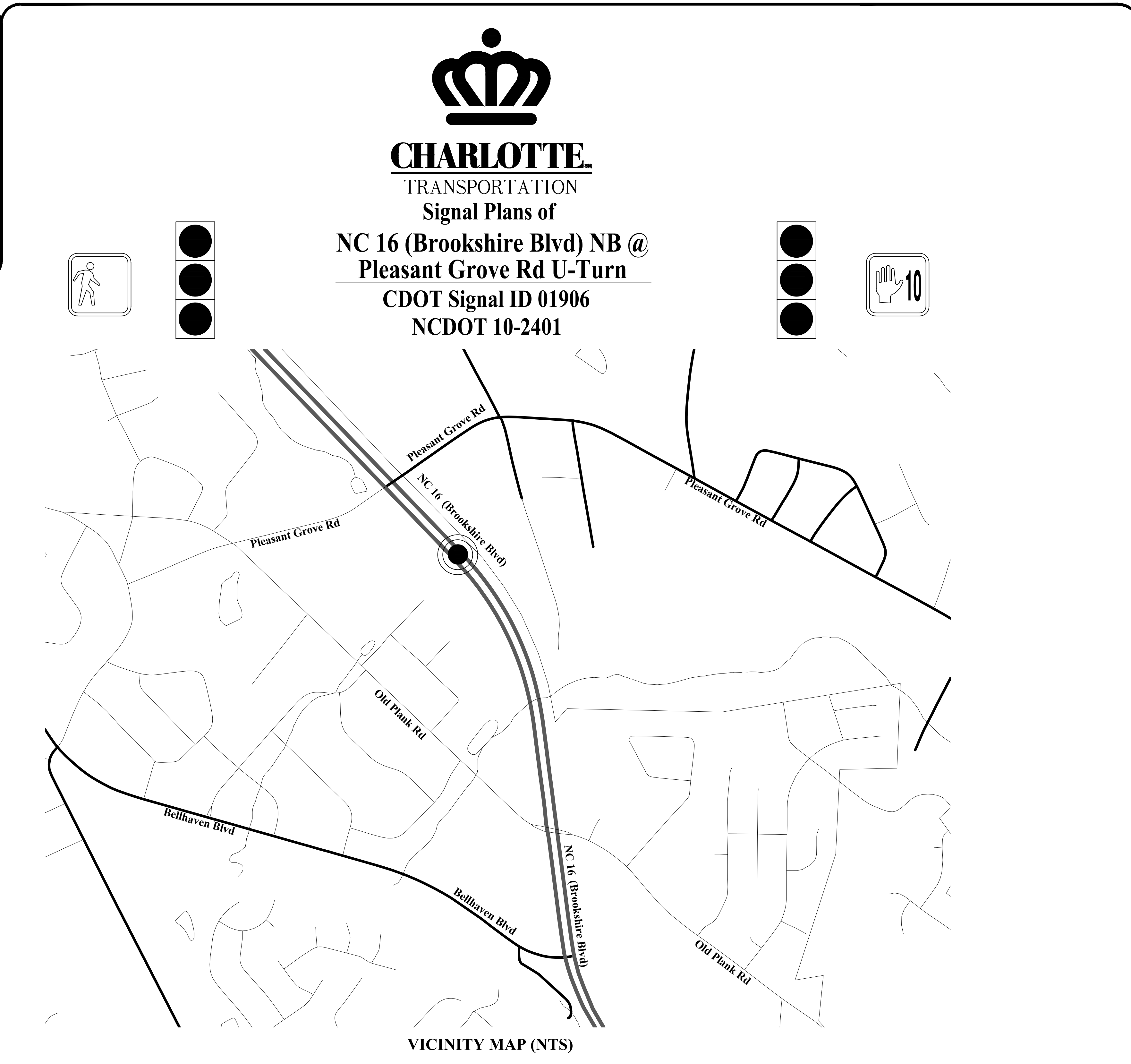

LEGEND		
PROPOSED	DESCRIPTION	EXISTING
	CONTROL BOX	
	METER PEDESTAL	
	PULL BOX	
	STEEL POLE	
	MAST ARM	
	PED PEDESTAL	
	UTILITY POLE	
	ANCHOR	
	SIGNAL HEAD	
	VIDEO CAMERA	
	OPTICOM	
	OBSERVATION CAM	
	DETECTOR	
	CONDUIT	
	INTERCONNECT	
	EDGE OF PVMT.	
	CURB & GUTTER	
	TUBULAR MARKER	
	GROUND SIGN	
	OVERHEAD SIGN	
	DOUBLE YELLOW	
	STOP BAR	
	WHITE SKIP	
	WHITE MINI	
	PAVEMENT ARROW	
	PROPERTY LINE	
	ROW	
	UTILITIES TELEPHONE UG CABLE SUE	
	UTILITIES SANITARY SEWER UG LINE	
	UTILITIES WATER UG LINE SUE	
	UTILITIES GAS UG LINE SUE	
	UTILITIES TELEPHONE UG FO SUE	
	OTHER CULTURE FENCE LINE	

PULLBOX ID		
	SIZE	PULLBOX TYPE
①	13"x24"x12"	LOOP
②	17"x30"x30"	FIBER OPTIC
③	24"x36"x24"	CONTROLLER / FIBER
④	30"x48"x36"	CONTROLLER
⑤	24"x24"x12"	CONTROLLER
UH-2	24"x36"x30"	FIBER SPLICE

NOTE:
PULLBOX MATERIAL MUST MEET OR EXCEED THE 2018 NCDOT STANDARD TRAFFIC SIGNAL SPECIFICATIONS.

PLANS PREPARED FOR:

City of Charlotte
Department of Transportation
 600 East 4th Street Charlotte, NC 28202
 Phone: (704) 336-4119
 Fax: (704) 336-4400

PLAN NOTES

- ALL PAVEMENT MARKING DIMENSIONS ARE APPROXIMATE.
- SIGNAL SHALL BE INSTALLED IN ACCORDANCE WITH THE LATEST NCDOT STANDARD SPECIFICATIONS AND PROJECT SPECIAL PROVISIONS.
- CITY WILL SUPPLY STREET NAME SIGNS FOR INSTALLATION.
- SEE SIGNAL COMMUNICATION PLANS FOR CONSTRUCTION RELATED TO SYSTEM, SHOWN ON SIGNAL PLANS AS EXISTING.
- ATTACHMENT HEIGHTS ARE ESTIMATED, BASED ON AVAILABLE INFORMATION AND EXISTING SURVEY ELEVATIONS. CONTRACTOR SHALL FIELD VERIFY ELEVATIONS TO ENSURE POLES OF SUFFICIENT LENGTH TO MAINTAIN MINIMUM REQUIRED CLEARANCE ABOVE THE ROADWAY.

PE SEAL

Seal: NORTH CAROLINA PROFESSIONAL ENGINEER SEAL 022516 LISA M. MOON 3/25/2022

Document No. 1 CONSIDERED FINAL UNLESS ALL SIGNATURES COMPLETED

PROJECT TEAM

Plans Prepared By:

DRMP, Inc.
 8000 Regency Parkway, Suite 110
 Cary, NC 27518
 NC License No. C-2213 (919) 650-1038

DESIGNER:	D. White
PROJECT ENGINEER:	C. Silver
PROJECT MANAGER:	L. Moon

Prepared for the Offices of:

CHARLOTTE
TRANSPORTATION

750 N. Greenfield Pkwy,
 Garner, NC 27529

SHEET
SIG4.0

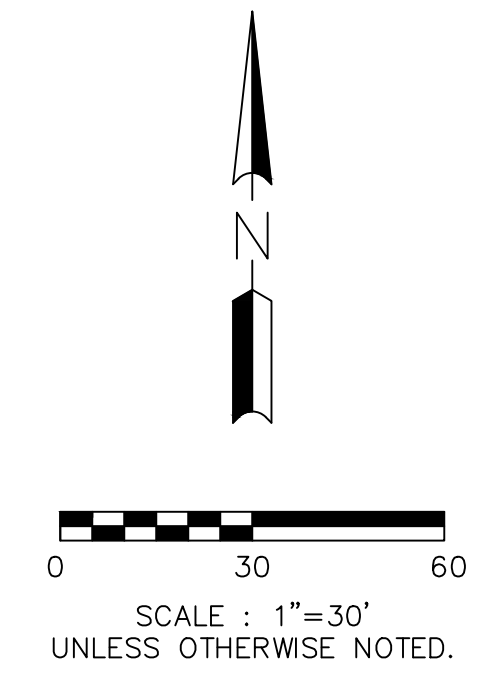
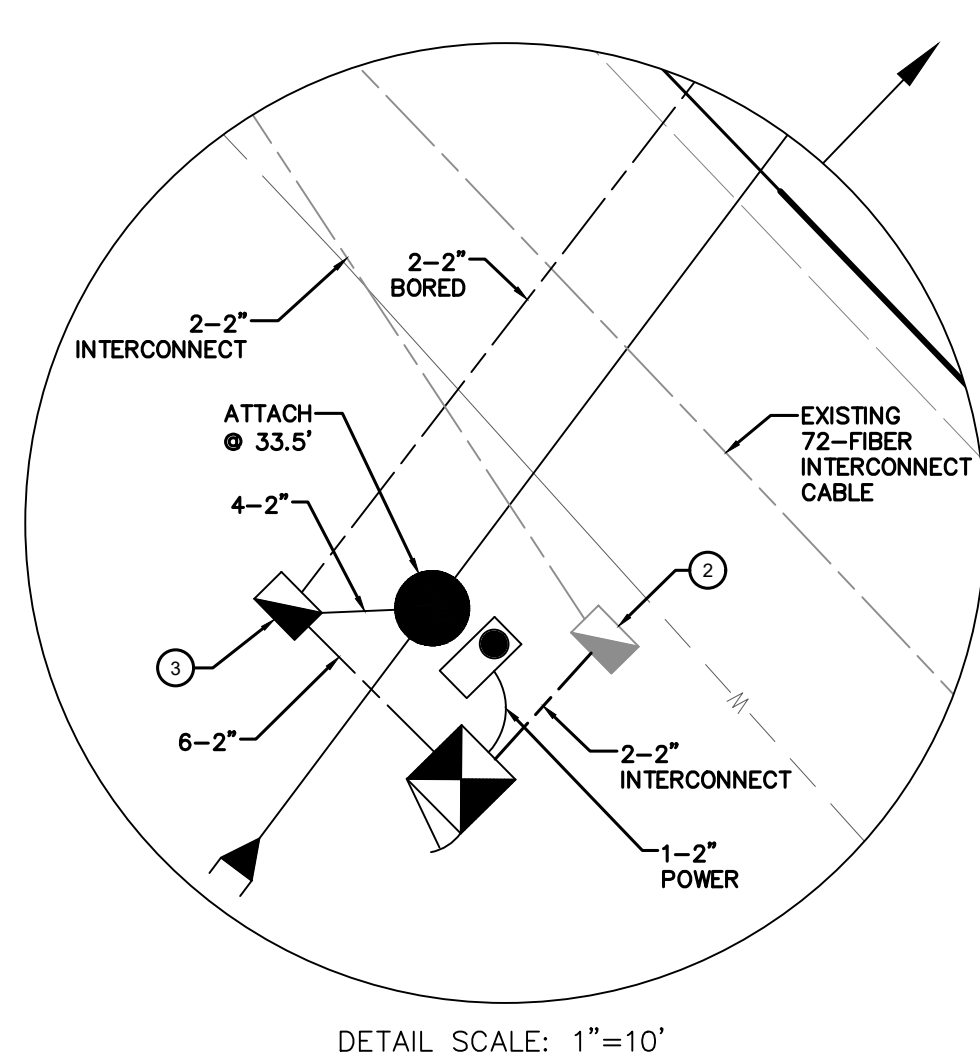
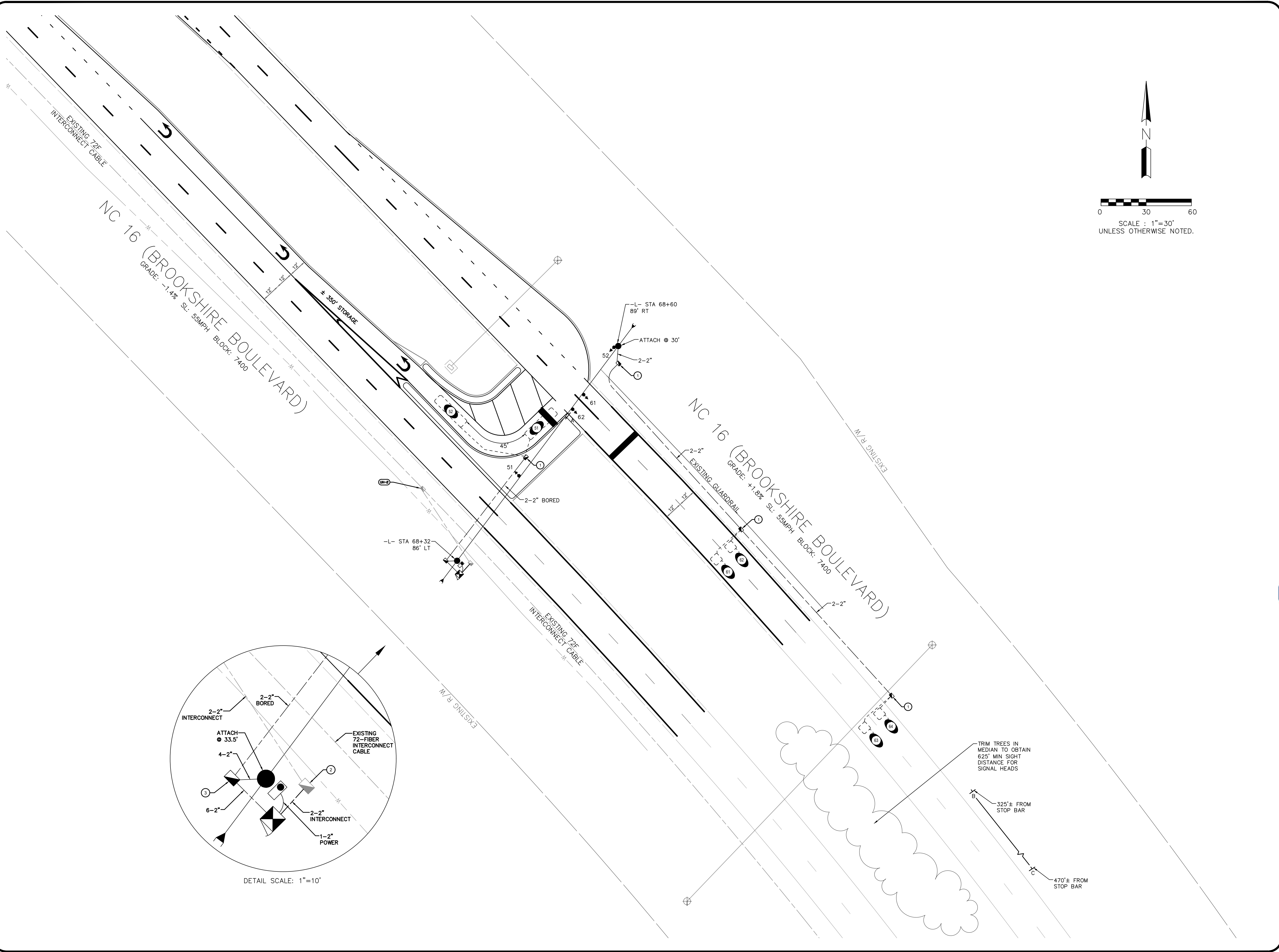

Plans Prepared For:
CITY OF CHARLOTTE
 DEPARTMENT OF
 TRANSPORTATION
 600 E. 4TH STREET, CHARLOTTE, NC 28202
 704.255.4191 FAX: 704.336.4660

Plans Prepared By:
DRMP
 DRMP, Inc.
 8000 Regency Parkway, Suite 110
 Charlotte, NC 28226
 NC License No. C-2216 (919) 659-1038

NO.	DATE	BY	REVISION DESCRIPTION

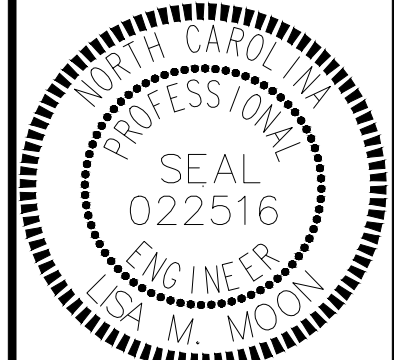

Designed by:
Lisa M. Moon /25/2022
NCES680300421

DOCUMENT NOT CONSIDERED FINAL UNLESS ALL SIGNATURES COMPLETED

W-5710AK JOB NO.	DJW PREPARED BY	03-2022 DATE
01906 SIGNAL NO.	10-2401 NC DOT ID NO.	L. MOON APPROVER

NC 16 (BROOKSHIRE BLVD) NB @ PLEASANT GROVE RD U-TURN

SHEET **SIG4.1** OF **SIG4.6**

SIGNAL PLAN

SIGNAL PHASING

Ring Configuration 1,2,3,4,5,6,7,8

1 NOT USED 5

2 NOT USED 6

3 NOT USED 7 NOT USED

4 NOT USED 8 NOT USED

SIGNAL SEQUENCE

RING 1	PHASE 1	PHASE 2	PHASE 3	PHASE 4	FLASH
SIGNAL ID NUMBER	R/W OTH	R/W OTH	R/W OTH	R/W OTH	
51,52	◀ ◀				
61,62		G Y			Y

RING 2	PHASE 5	PHASE 6	PHASE 7	PHASE 8	FLASH
SIGNAL ID NUMBER	R/W OTH	R/W OTH	R/W OTH	R/W OTH	

OVERLAP PHASE

OVERLAP PHASE	OL-A/	OL-B/	OL-C/	OL-D/	FLASH
SIGNAL ID NUMBER	R/W OTH	R/W OTH	R/W OTH	R/W OTH	

OVERLAP PHASE	OL-E/	OL-F/	OL-G/	OL-H/	FLASH
SIGNAL ID NUMBER	R/W OTH	R/W OTH	R/W OTH	R/W OTH	

◀ RED ARROW ◀ YELLOW ARROW
 ◀ GREEN ARROW ✨ FLASHING YELLOW ARROW

TURNING MOVEMENT COUNT

NOT AVAILABLE

SIGN ID

A
R3-2
36" x 36"

B
W3-3
36" x 36"

C
W3-4
36" x 36"

CLEARANCE INTERVALS

Phase	1	2	3	4	5	6	7	8
% Grade					-1.4%	1.8%		
Distance					60	83		
Approach Speed (mph)					15	55		
Yellow					3.0	5.0		
All Red					2.8	1.1		
Total Clearance					5.8	6.1		

SIGNAL HEAD ID

61,62

51

52

MALFUNCTION MANAGEMENT UNIT / CONFLICT MONITOR

PROGRAMMING DETAIL

(program card and tables as shown)

MMU PROGRAMMING CARD

OPTION	SETTING
RECURRENT PULSE	ON
WALK DISABLE	OFF
LOG CVM FAULTS	ON
EXTERN WATCHDOG	OFF
24V-2-12VDC	OFF
PGM CARD MEMORY	ON
LEDguard	ON
FORCE TYPE 16	OFF
TYPE12-SDLC	OFF
VM 3xDay Latch	ON

ECONOLITE EOS-2070 SPECIAL MMU PROGRAMMING

(program controller as shown)

- From Main Menu select **1. CONFIGURATION**
- From CONFIGURATION Submenu select **1. CABINET**
- From PORT 1 (SDLC) Submenu select **4. MONITOR PROGRAMMING**

CAUTION!

Set intersection to Flash before attempting to enter or change any MMU programming data.

This programming and that of the MMU programming card must match exactly. If they do not, the intersection will be placed into Flash.

MMU PROGRAM [MANUAL]

CH 6 5 4 3 2 1 0 9 8 7 6 5 4 3 2

1

2

3

4

5

6

7

8

9

10

11

12

13

14

15

END PROGRAMMING

CHANNEL NUMBER	ENABLE/DISABLE
1	DISABLE
2	DISABLE
3	DISABLE
4	DISABLE
5	ENABLE
6	ENABLE
7	DISABLE
8	DISABLE
9	DISABLE
10	DISABLE
11	DISABLE
12	DISABLE
13	DISABLE
14	DISABLE
15	DISABLE
16	DISABLE

DETECTOR RACK SETUP

INSERT DETECTOR CARDS IN RACK ACCORDING TO THE DETAIL SHOWN BELOW. PARTICULAR DETECTOR CHANNELS WILL CALL PHASES INDICATED.

DET BIU #1	CH3	CH1	CH3	CH1	S	S	S	S	S	S	DET BIU #2
	L3	L1	L7	L5	EMPTY	EMPTY	EMPTY	EMPTY	EMPTY	EMPTY	
	Ø 6	Ø 5	NOT USED	Ø 6							
	61	51		63							
CH4	CH2	CH4	CH2								
L4	L2	L8	L6								
Ø 6	Ø 5	NOT USED	Ø 6								
62	52		64								

APS PUSH BUTTON INPUT SETUP

W-5710AK	JOB NO.	DJW	PREPARED BY	03-2022	DATE
01906	SIGNAL NO.	10-2401	NC DOT ID NO.	L. MOON	APPROVER

NC 16 (BROOKSHIRE BLVD) NB @ PLEASANT GROVE RD U-TURN

SIGNAL DETAILS

SHEET SIG4.2 OF SIG4.6

City of Charlotte
Department of Transportation

Plans Prepared For: City of Charlotte, Department of Transportation, 600 E. 4th St., Charlotte, NC 28202, Tel: 704.259.4191, Fax: 704.336.4660

Plans Prepared By: DRMP, Inc., 8000 Regency Parkway, Suite 110, Charlotte, NC 28226, Tel: (919) 859-1038, NC License No. C-2216

REVISION DESCRIPTION

NO. DATE BY

Professional Engineer Seal: Lisa M. Moon, No. 022516, State of North Carolina

Don't Sign by: Lisa M. Moon, 3/25/2022

DOCUMENT NOT CONSIDERED FINAL UNLESS ALL SIGNATURES COMPLETED

LEGEND
 ○ EXISTING SPLICE
 ● NEW SPLICE
 ALL UNUSED FIBERS ARE TO BE EXPRESSED THROUGH.

SPLICE 01906

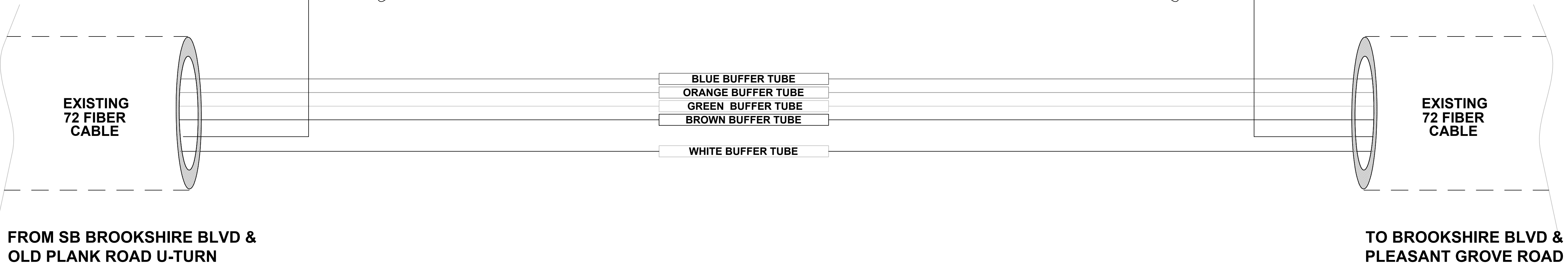
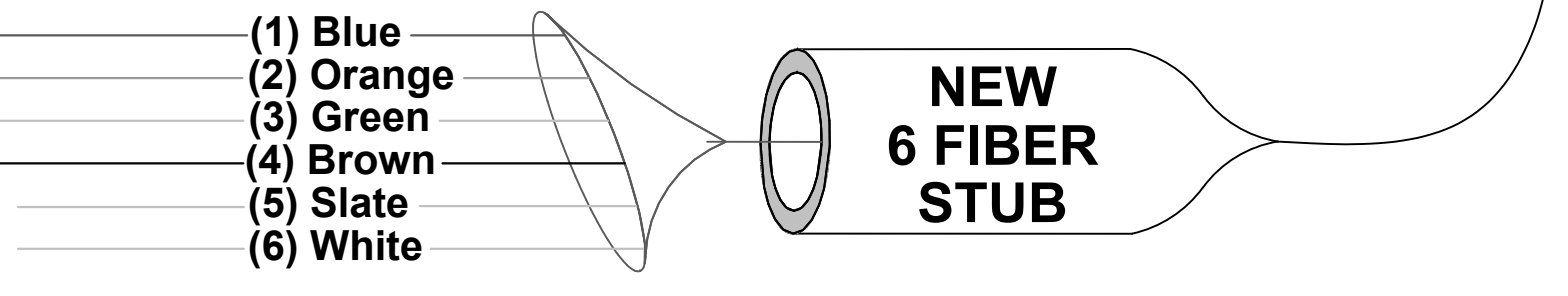
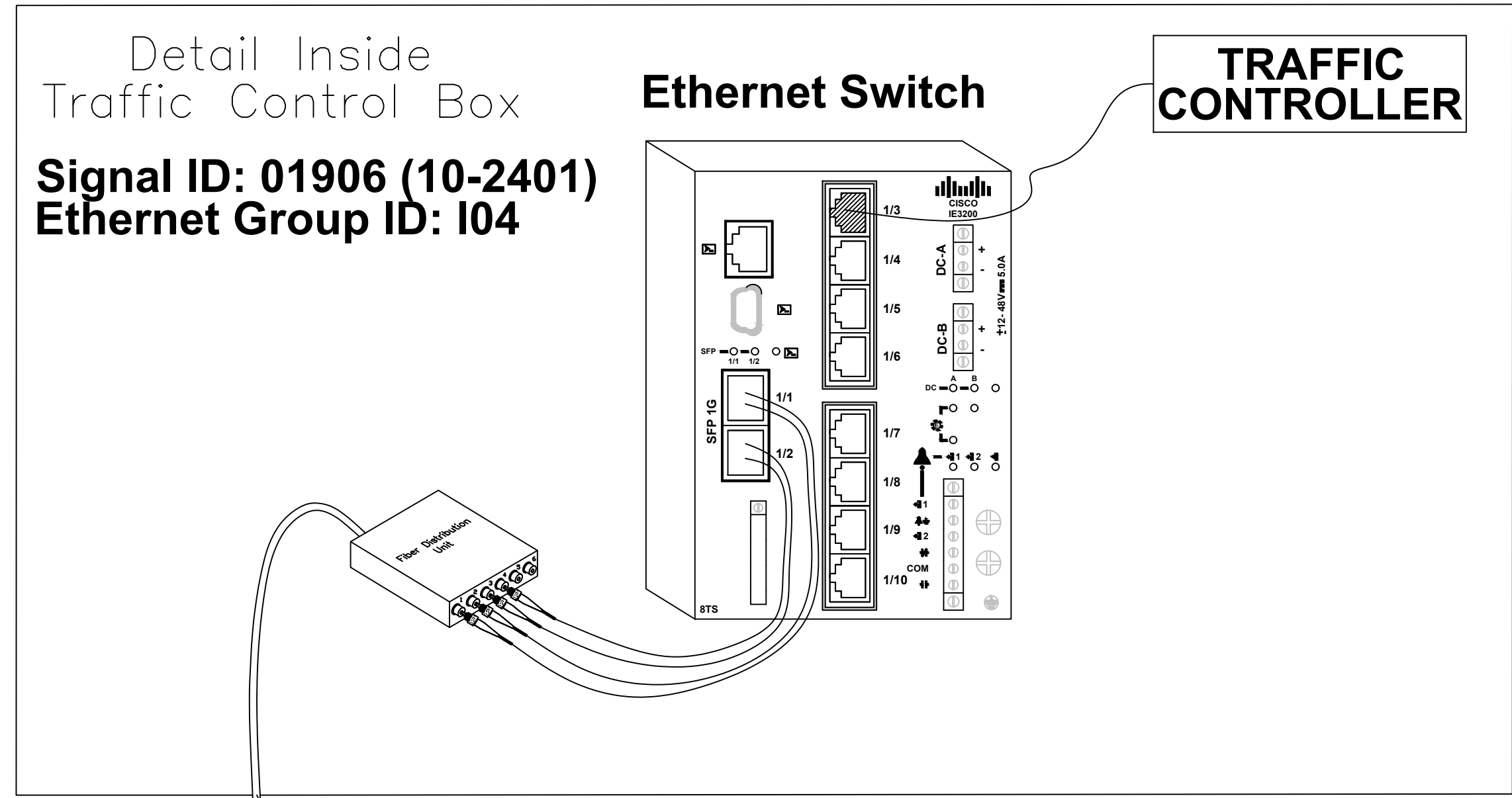

SPLICE CASE IN HANDHOLE# 15 ON NB BROOKSHIRE BLVD AT PLEASANT GROVE RD U-TURN



Plans Prepared For:
 CITY OF CHARLOTTE
 DEPARTMENT OF TRANSPORTATION
 600 E. 4TH ST. FLOOR 1100
 CHARLOTTE, NC 28202
 704.259.4191 FAX: 704.336.4660

Plans Prepared By:
DRMP
 DRMP, Inc.
 8000 Regency Parkway, Suite 110
 Cary, NC 27513
 NC License No. C-2216 (919) 659-1038

NO.	DATE	BY	REVISION DESCRIPTION

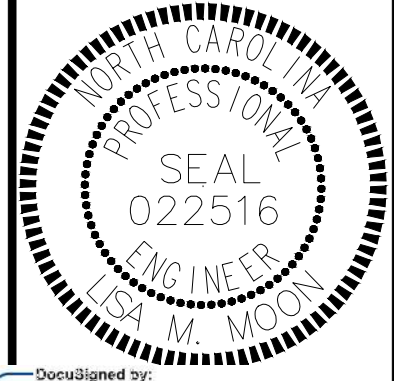

DocuSigned by:
 Lisa M. Moon 3/25/2022

01906	W-5710AK	03-2022
SIGNAL NO.	JOB NO.	DATE
10-2401	DJW	
NC DOT ID NO.	PREPARED BY	
	L. MOON	
	APPROVER	

NC 16 (BROOKSHIRE BLVD) NB @ PLEASANT GROVE RD U-TURN

FIBER OPTIC SPLICE DETAILS

SIGNAL HEAD WIRING

		SIGNAL HEAD HOOK UP CHART															
CHANNEL		1	2	3	4	5	6	7	8	9	10	11	12	13	14	15	16
PHASE		1	2	3	4	5	6	7	8	2 PED	4 PED	6 PED	8 PED	OL-A	OL-B	OL-C	OL-D
SIGNAL HEAD NO.		NU	NU	NU	NU	51	52	61	62	NU	NU	NU	NU	NU	NU	NU	NU
RED	Wire							61R	62R								
	Terminal							LS6-R	[61R]								
YELLOW	Wire							61Y	62Y								
	Terminal							LS6-Y	[61Y]								
GREEN	Wire							61G	62G								
	Terminal							LS6-G	[61G]								
RED ARROW	Wire					51RS	52RS										
	Terminal					LS5-R	LS5-R										
YELLOW ARROW	Wire					51YS	52YS										
	Terminal					LS5-Y	LS5-Y										
FLASHING YELLOW	Wire																
	Terminal																
GREEN ARROW	Wire					51GS	52GS										
	Terminal					LS5-G	LS5-G										

[XX*] = TERMINAL BLOCK IN SIGNAL HEAD | LSX* = TERMINAL IN LOAD BAY | NU = NOT USED

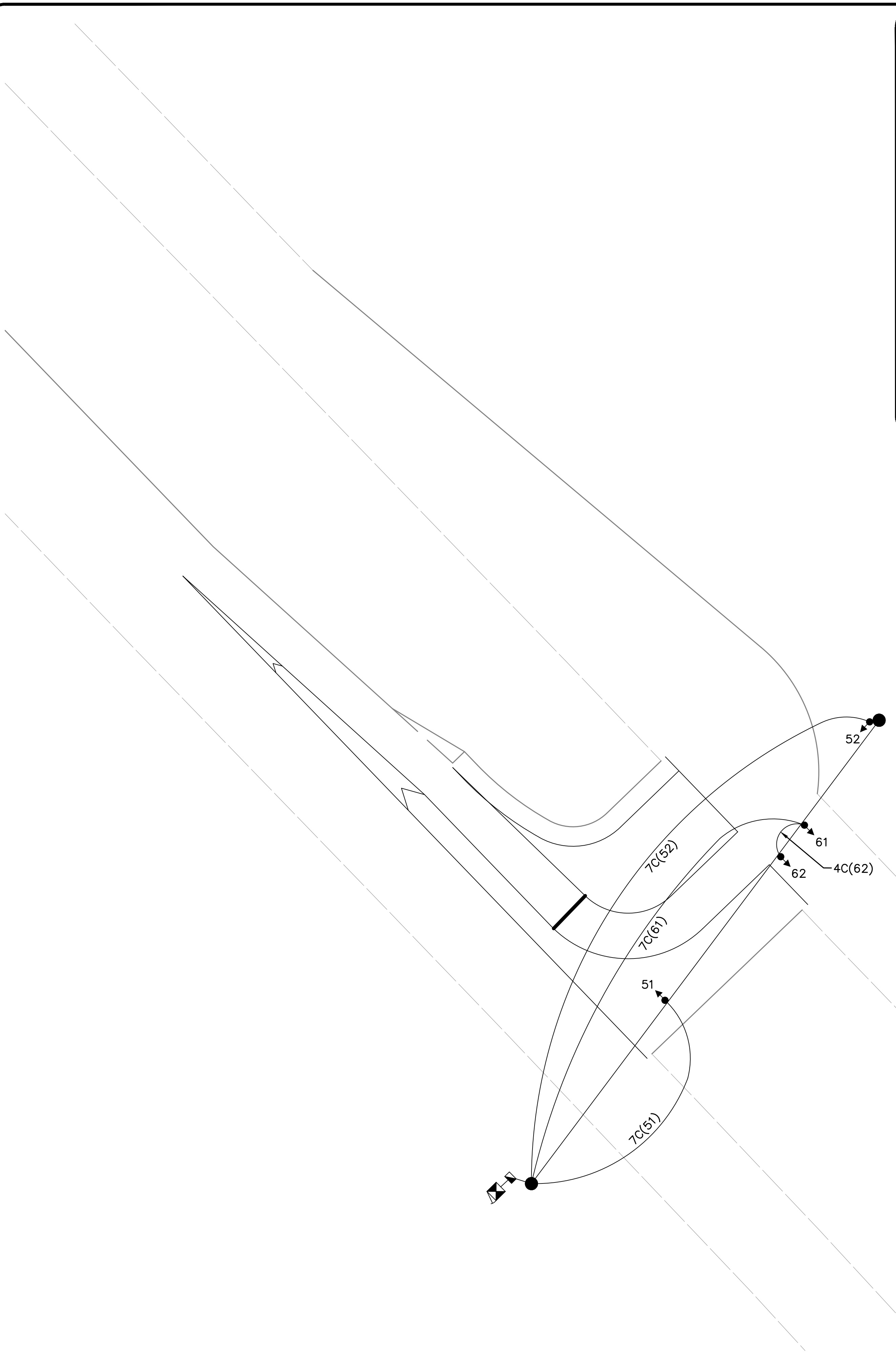

SIGNAL WIRE NAMING CONVENTION:
CABLES:
 xC(nn) x = #of conductors in cable, nn = cable number
WIRES:
 nnA nn = cable number, A = conductor in cable
EXAMPLE: 7C(41)

NOTE: Conductor colors may vary. Record plan actual colors installed.



Plans Prepared For:
CITY OF CHARLOTTE
 DEPARTMENT OF
 TRANSPORTATION
 600 E. 4th Street, Charlotte, NC 28202
 704.358.4181 FAX: 704.358.4660

Plans Prepared By:
DRMP
 DRMP, Inc.
 8000 Regency Parkway, Suite 110
 Cary, NC 27513
 NC License No. C-2216 (919) 659-1038

NO.	DATE	BY	REVISION DESCRIPTION



Designed by
Lisa M. Moon /25/2022
SACFESB0R200421

DOCUMENT NOT CONSIDERED FINAL UNLESS ALL SIGNATURES COMPLETED

01906	W-5710AK		
SIGNAL NO.	JOB NO.	DJW	DATE
10-2401		PREPARED BY	03-2022
NCDOT ID NO.			
L. MOON		APPROVER	

SHEET
SIG4.4
OF
SIG4.6

NC 16 (BROOKSHIRE BLVD) NB @ PLEASANT GROVE RD U-TURN

SIGNAL WIRING DIAGRAM

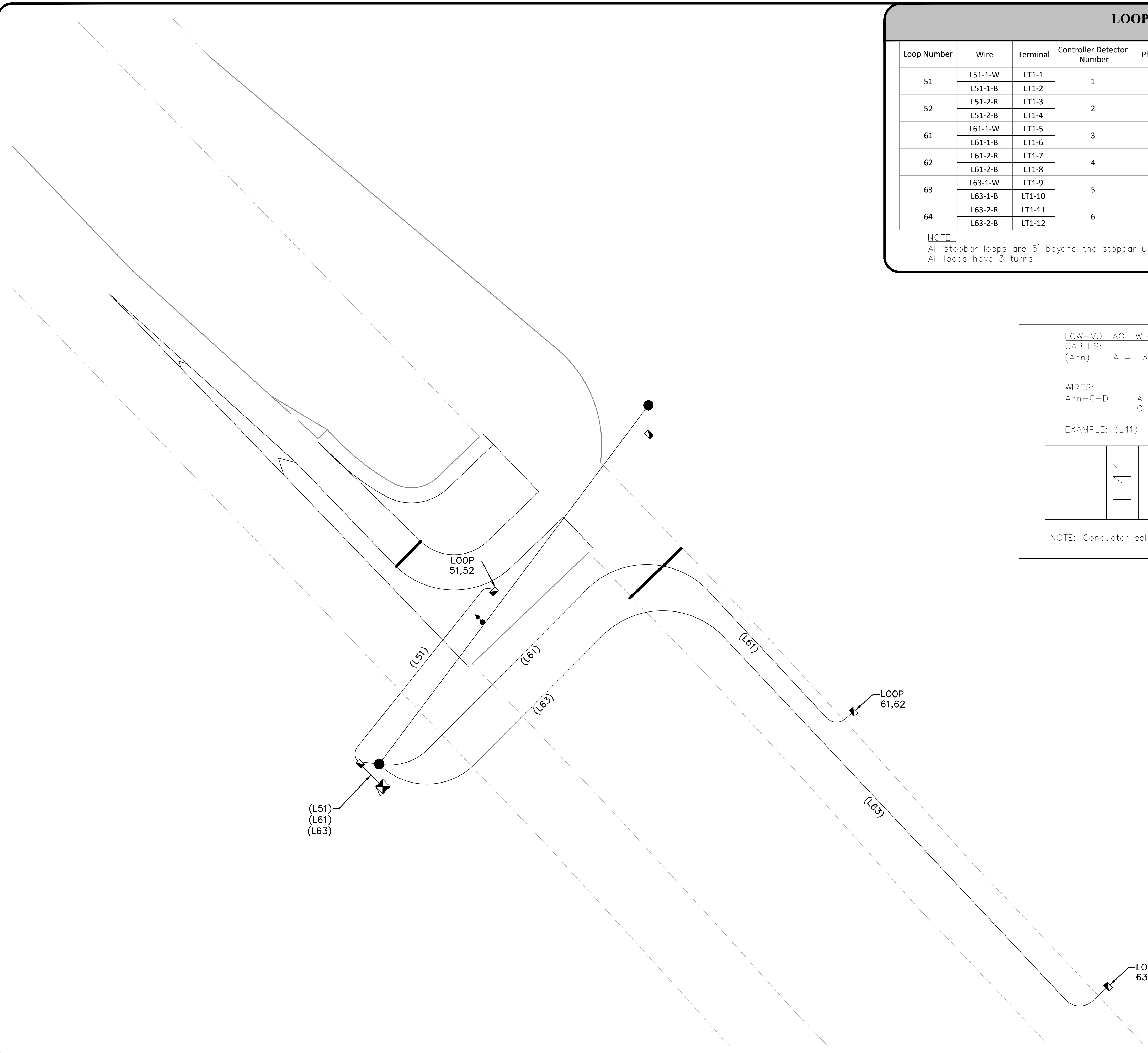

LOOP WIRING

Loop Number	Wire	Terminal	Controller Detector Number	Phase	Timing		Size	Comments
					Feature	Time (sec)		
51	L51-1-W	LT1-1	1	5	-	-	6'X25'	@ STOP BAR
	L51-1-B	LT1-2						
52	L51-2-R	LT1-3	2	5	-	-	6'X25'	65' FROM STOP BAR
	L51-2-B	LT1-4						
61	L61-1-W	LT1-5	3	6	-	-	6'X6'	130' FROM STOP BAR
	L61-1-B	LT1-6						
62	L61-2-R	LT1-7	4	6	-	-	6'X6'	130' FROM STOP BAR
	L61-2-B	LT1-8						
63	L63-1-W	LT1-9	5	6	-	-	6'X6'	280' FROM STOP BAR
	L63-1-B	LT1-10						
64	L63-2-R	LT1-11	6	6	-	-	6'X6'	280' FROM STOP BAR
	L63-2-B	LT1-12						

NOTE:
All stopbar loops are 5' beyond the stopbar unless otherwise noted.
All loops have 3 turns.

LOW-VOLTAGE WIRE NAMING CONVENTION:
CABLES:
 (Ann) A = Loops(L)/Pushbutton(B) nn = cable number

WIRES:
 Ann-C-D A = Loops(L)/Pushbutton(B), nn = cable number,
 C = pair number, D = conductor in pair

EXAMPLE: (L41)

NOTE: Conductor colors may vary. Record plan actual colors installed.

NOTE
 CDOT TO PROGRAM DETECTOR
 TYPES AND TIMERS (EXTEND AND
 DELAY) AS SHOWN IN LOOP WIRING
 CHART ABOVE INTO CONTROLLER



Plans Prepared For:
CITY OF CHARLOTTE
 DEPARTMENT OF
 TRANSPORTATION
 600 E. 4TH STREET, FLOOR 1300, NC 28202
 704.259.4191 FAX: 704.336.4660

Plans Prepared By:
DRMP
 DRMP, Inc.
 8000 Regency Parkway, Suite 110
 Cary, NC 27513
 NC License No. C-2216 (919) 659-1038

NO.	DATE	BY	REVISION DESCRIPTION

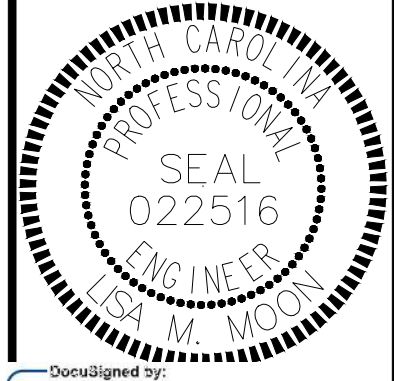

Designed by: *Lisa M. Moon* 2/25/2022
 DOCUMENT NOT CONSIDERED FINAL
 UNLESS ALL SIGNATURES COMPLETED

W-5710AK JOB NO.	DJW PREPARED BY	03-2022 DATE
01906 SIGNAL NO.	10-2401 NCDOT ID NO.	L. MOON APPROVER

NC 16 (BROOKSHIRE BLVD) NB
 @ PLEASANT GROVE RD U-TURN
**LOW VOLTAGE
 WIRING DIAGRAM**

SHEET
SIG4.5
 OF
SIG4.6

NOTE:
 ALL LEAD-IN WIRE SHOULD BE TWO PAIR CABLE

NOTES

1. To prevent "flash-conflict" problems, wire all unused load switches to flash red. Verify that signal heads flash in accordance with the signal plans.
2. To prevent red failures on unused monitor channels, tie unused load switch red outputs 1, 2, 3, 4, 7, 8, 9, 10, 11, 12, 13, 14, 15 and 16 to load switch AC+ by inserting a jumper plug in the unused load switch socket from pin 1 (LS AC+) to pin 3 (RED out). Make sure all flash transfer relays are in place.
- ◆ 3. Program controller to start up in phase 6 Green.
- ◆ 4. Set power-up flash time to 12 seconds and implement on the Malfunction Management Unit. Set controller power-up flash time to 22 seconds.
- ◆ 5. Program detectors in accordance with the manufacturer's instructions to accomplish the detection schemes shown on the signal design plans.
- ◆ 6. Program detector call delay and extension timing on the controller, unless otherwise specified.
7. Set all detector card unit channels to "presence" mode.
8. The cabinet and controller are a part of the Charlotte Signal System.

EQUIPMENT INFORMATION

CONTROLLER.....2070LX
 CABINETTS-2
 SOFTWAREECONOLITE EOS-2070
 CABINET MOUNT.....BASE
 LOADBAY POSITIONS.....16
 LOAD SWITCHES USED.....5,6
 PHASES USED.....5,6
 OLA.....NOT USED
 OLB.....NOT USED
 OLC.....NOT USED
 OLD.....NOT USED

◆ Software and Programming by CDOT

City of Charlotte Department of Transportation (CDOT) to provide EOS Software and do all Programming of the controller database. Contractor to provide CDOT with controller for programming a minimum of two weeks prior to installation. CDOT will return controller, fully programmed for contractor to install and integrate into the controller cabinet.



Plans Prepared For:
CITY OF CHARLOTTE
 DEPARTMENT OF
 TRANSPORTATION
 600 E. 4TH ST. FLOOR 1000
 CHARLOTTE, NC 28202
 PH: 704.359.4191 FAX: 704.359.4660

Plans Prepared By:

DRMP, Inc.
 8000 Regency Parkway, Suite 110
 Cary, NC 27513
 NC License No. C-22516 (919) 659-1038

NO.	DATE	BY	REVISION DESCRIPTION



Digitally signed by *Lisa M. Moon* on 3/25/2022
 DN: cn=Lisa M. Moon, o=DRMP, ou=DRMP, email=L.Moon@drmp.com

DOCUMENT NOT CONSIDERED FINAL UNLESS ALL SIGNATURES COMPLETED

W-5710AK JOB NO.	D.J.W PREPARED BY	03-2022 DATE
01906 SIGNAL NO.	10-2401 NCDOT ID NO.	L. MOON APPROVER

NC 16 (BROOKSHIRE BLVD) NB
@ PLEASANT GROVE RD U-TURN
MISCELLANEOUS
DETAILS

SHEET
SIG4.6
 OF
SIG4.6

Signal ID 00940 / NCDOT 10-0880

NC 16 (Brookshire Blvd) @ Pleasant Grove Rd

INDEX OF SHEETS	
Cover Sheet	SIG5.0
Temporary Signal Plan	SIG5.1
Temporary Signal Details	SIG5.2
Signal Plan	SIG5.3
Signal Details	SIG5.4
Splice Detail	SIG5.5
Signal Wiring Diagram	SIG5.6
Low Voltage Wiring Diagram	SIG5.7
Miscellaneous Details	SIG5.8
TOTAL SHEETS	9

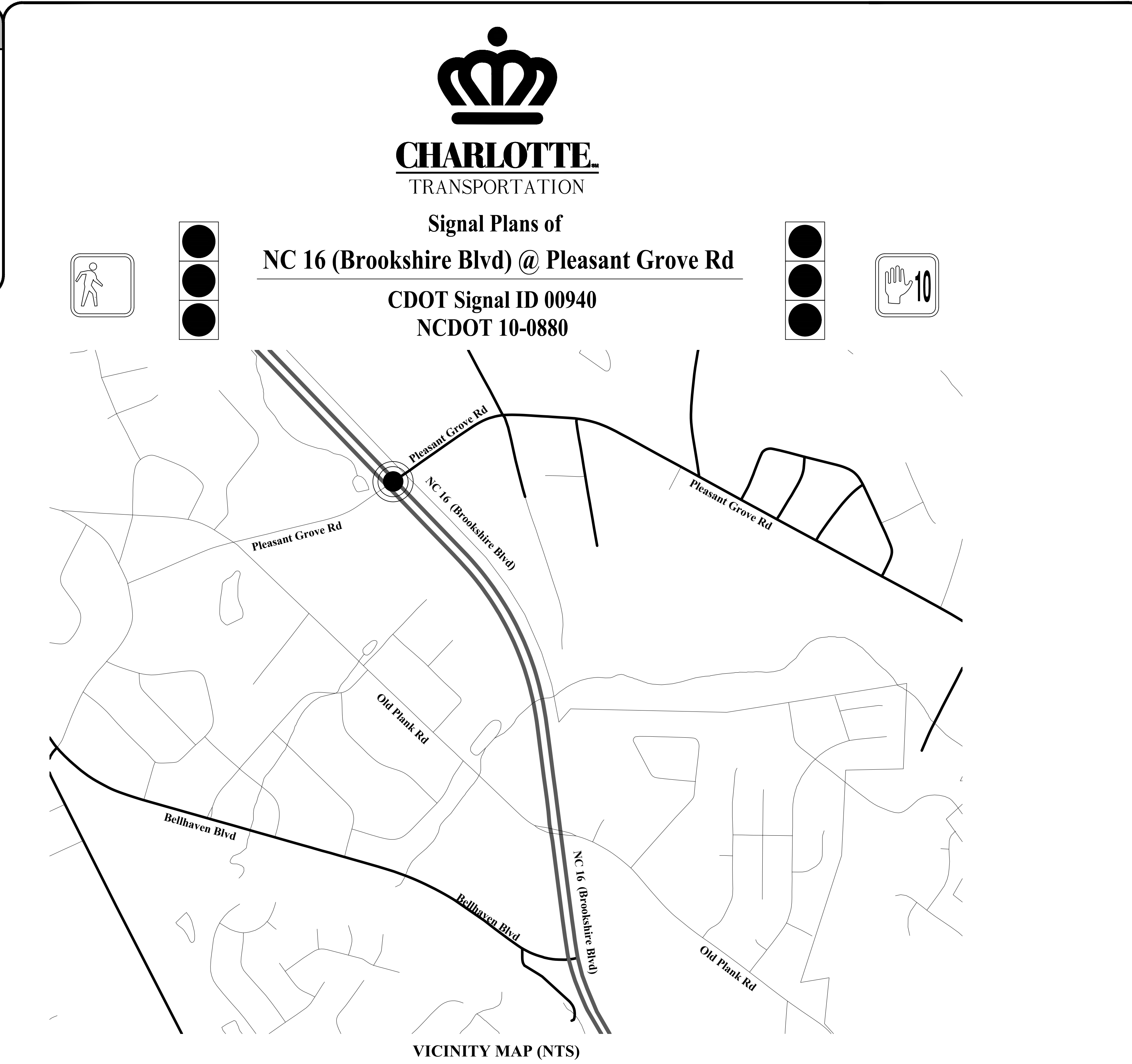

LEGEND		
PROPOSED	DESCRIPTION	EXISTING
	CONTROL BOX	
	METER PEDESTAL	
	PULL BOX	
	STEEL POLE	
	MAST ARM	
	PED PEDESTAL	
	UTILITY POLE	
	ANCHOR	
	SIGNAL HEAD	
	VIDEO CAMERA	
	OPTICOM	
	OBSERVATION CAM	
	DETECTOR	
	CONDUIT	
	INTERCONNECT	
	EDGE OF PVMT	
	CURB & GUTTER	
	TUBULAR MARKER	
	GROUND SIGN	
	OVERHEAD SIGN	
	DOUBLE YELLOW	
	STOP BAR	
	WHITE SKIP	
	WHITE MINI	
	PAVEMENT ARROW	
	PROPERTY LINE	
	ROW	
	UTILITIES TELEPHONE UG CABLE SUE	
	UTILITIES SANITARY SEWER UG LINE	
	UTILITIES WATER UG LINE SUE	
	UTILITIES GAS UG LINE SUE	
	UTILITIES TELEPHONE UG FO SUE	
	OTHER CULTURE FENCE LINE	

PULLBOX ID		
	SIZE	PULLBOX TYPE
①	13"x24"x12"	LOOP
②	17"x30"x30"	FIBER OPTIC
③	24"x36"x24"	CONTROLLER / FIBER
④	30"x48"x36"	CONTROLLER
⑤	24"x24"x12"	CONTROLLER
UH-2	24"x36"x30"	FIBER SPLICE

NOTE:
PULLBOX MATERIAL MUST MEET OR EXCEED THE 2018 NCDOT STANDARD TRAFFIC SIGNAL SPECIFICATIONS.

PLANS PREPARED FOR:

City of Charlotte
Department of Transportation
 600 East 4th Street Charlotte, NC 28202
 Phone: (704) 336-4119
 Fax: (704) 336-4400

PLAN NOTES

- ALL PAVEMENT MARKING DIMENSIONS ARE APPROXIMATE.
- SIGNAL SHALL BE INSTALLED IN ACCORDANCE WITH THE LATEST NCDOT STANDARD SPECIFICATIONS AND PROJECT SPECIAL PROVISIONS.
- CITY WILL SUPPLY STREET NAME SIGNS FOR INSTALLATION.
- SEE SIGNAL COMMUNICATION PLANS FOR CONSTRUCTION RELATED TO SYSTEM, SHOWN ON SIGNAL PLANS AS EXISTING.
- FYA #11, #12, #51 AND #52 WILL OPERATE PROTECTED-ONLY FROM 0500-2200 7 DAYS A WEEK, AND PROTECTED-PERMISSIVE ALL OTHER TIMES.
- ATTACHMENT HEIGHTS ARE ESTIMATED, BASED ON AVAILABLE INFORMATION AND EXISTING SURVEY ELEVATIONS. CONTRACTOR SHALL FIELD VERIFY ELEVATIONS TO ENSURE POLES OF SUFFICIENT LENGTH TO MAINTAIN MINIMUM REQUIRED CLEARANCE ABOVE THE ROADWAY.

PE SEAL

Don't sign it if:
 - The seal is not in the correct position.
 - The seal is not considered final unless all signatures are completed.

PROJECT TEAM

DESIGNER:	D. White
PROJECT ENGINEER:	C. Silver
PROJECT MANAGER:	L. Moon

Plans Prepared By:

 DRMP, Inc.
 8000 Regency Parkway, Suite 110
 Cary, NC 27518
 NC License No. C-2213 (919) 650-1038

Prepared for the Offices of:

CHARLOTTE
TRANSPORTATION

750 N. Greenfield Pkwy,
 Garner, NC 27529

SHEET
SIG5.0

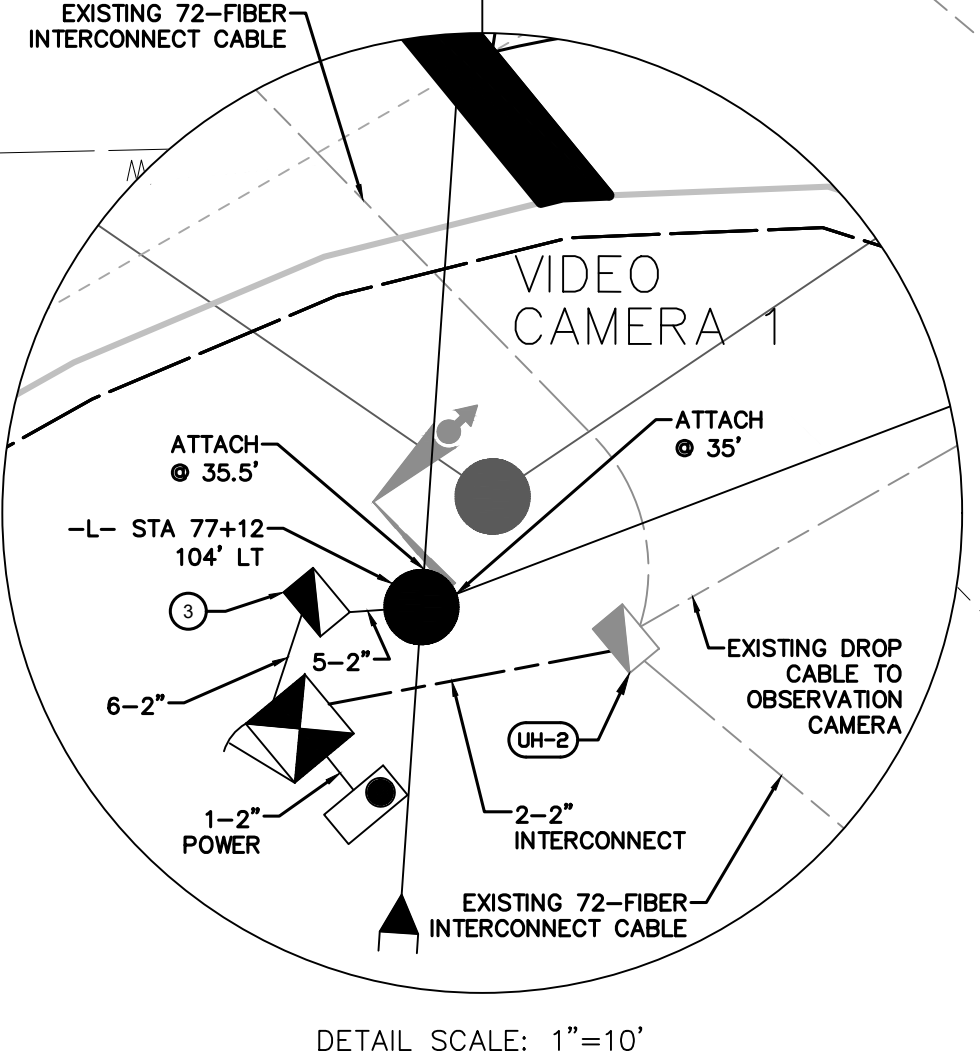
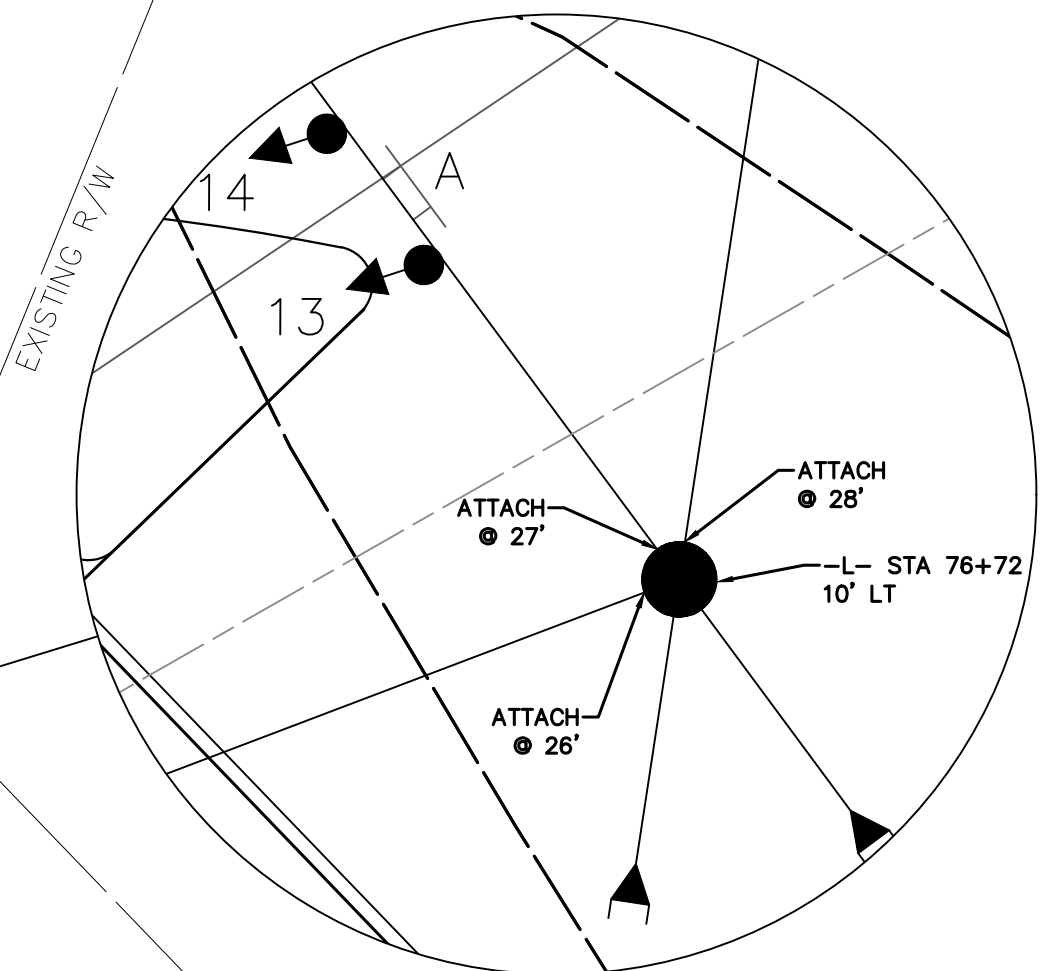
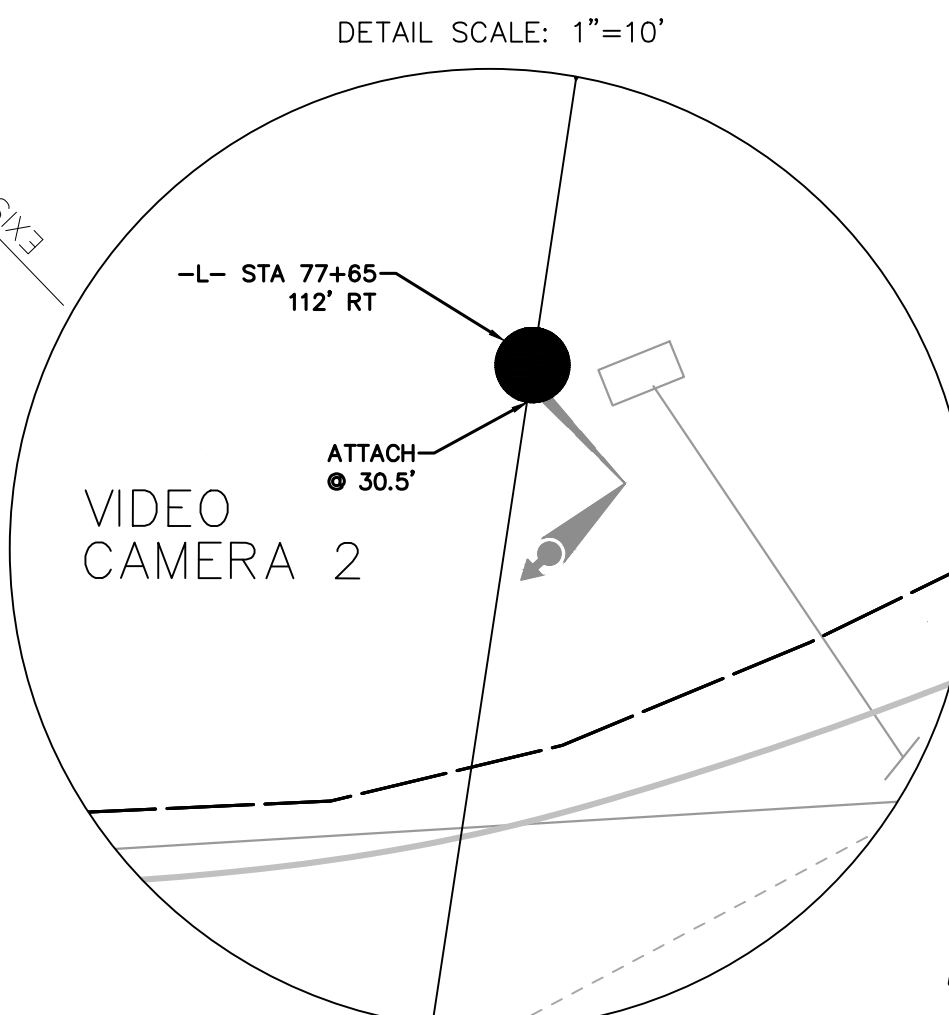
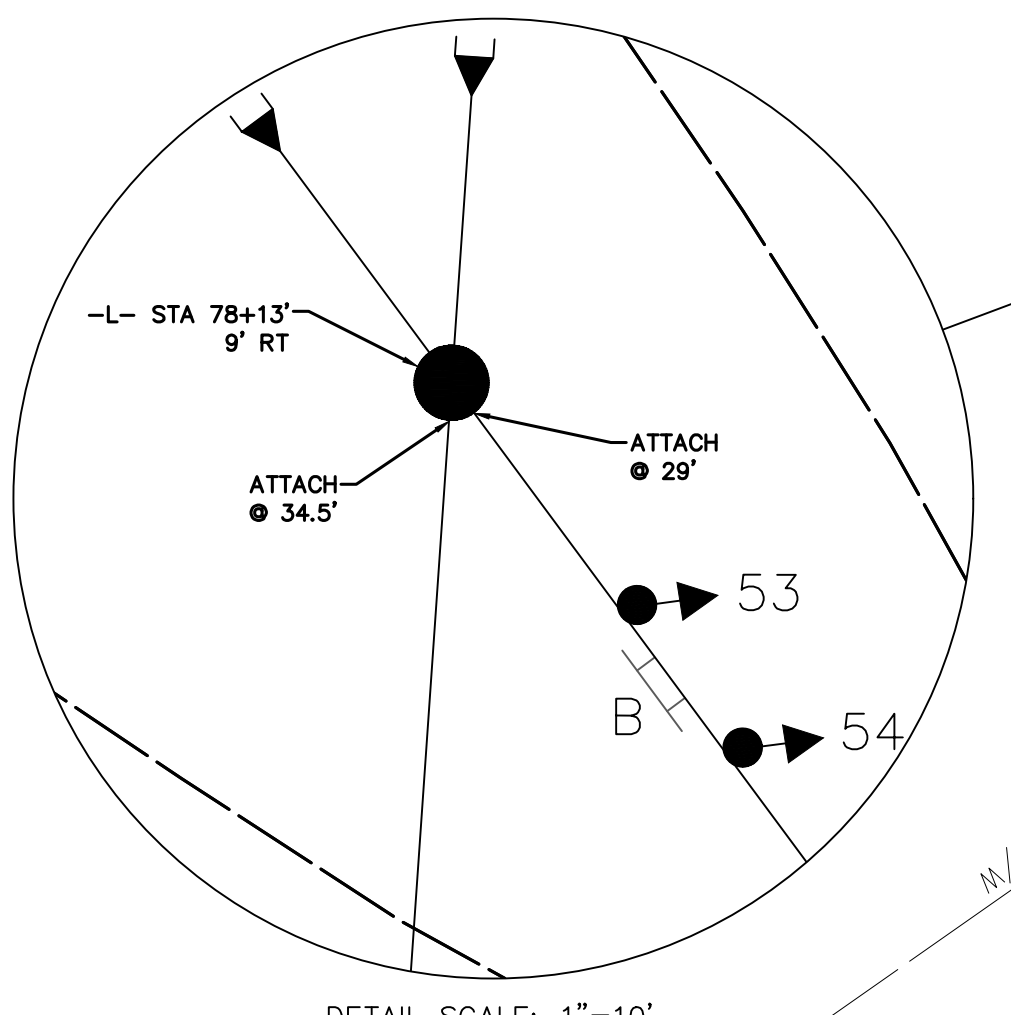
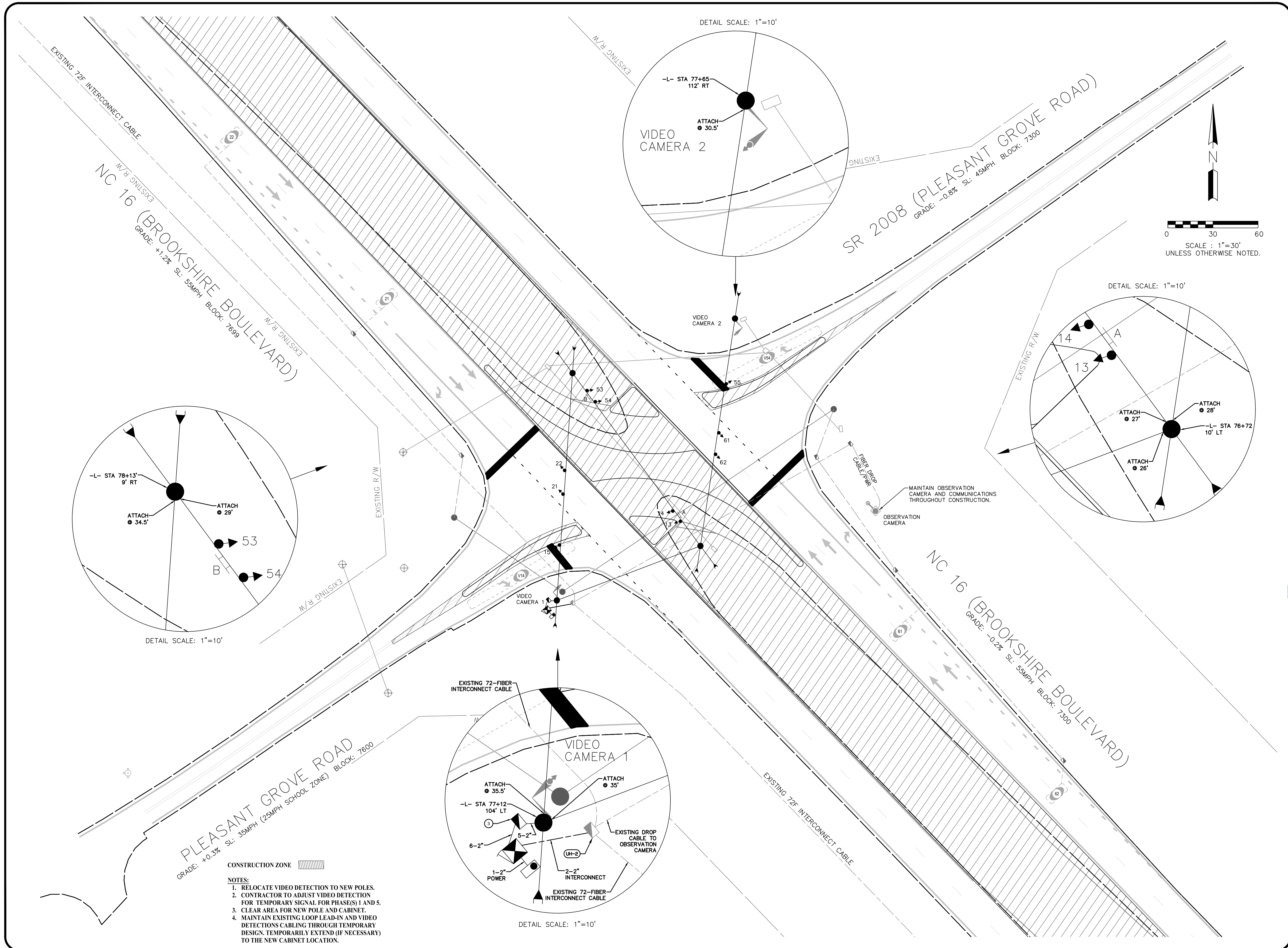

- NOTES:**
1. RELOCATE VIDEO DETECTION TO NEW POLES.
 2. CONTRACTOR TO ADJUST VIDEO DETECTION FOR TEMPORARY SIGNAL FOR PHASE(S) 1 AND 5.
 3. CLEAR AREA FOR NEW POLE AND CABINET.
 4. MAINTAIN EXISTING LOOP LEAD-IN AND VIDEO DETECTIONS CABLING THROUGH TEMPORARY DESIGN. TEMPORARILY EXTEND (IF NECESSARY) TO THE NEW CABINET LOCATION.



Plans Prepared For:
CITY OF CHARLOTTE
 DEPARTMENT OF
 TRANSPORTATION
 600 E. 4TH STREET, FLOOR 200, NC 28202
 704.259.4191 FAX: 704.336.4660

Plans Prepared By:
DRMP
 DRMP, Inc.
 8000 Regency Parkway, Suite 110
 Cary, NC 27513
 919.221.2700 (919) 659-1088
 NC License No. C-2216

NO.	DATE	BY	REVISION DESCRIPTION



Designed by:
 Lisa M. Moon
 3/25/2022
 SSC6588B3D0421

DOCUMENT NOT CONSIDERED FINAL UNLESS ALL SIGNATURES COMPLETED

W-5710AK	JOB NO.	DJW	PREPARED BY	03-2022	DATE
00940	SIGNAL NO.	10-0880	NC DOT ID NO.	L. MOON	APPROVER

SHEET **SIG5.1** OF **SIG5.8**
NC 16 (BROOKSHIRE BLVD) @ PLEASANT GROVE RD
TEMPORARY SIGNAL PLAN

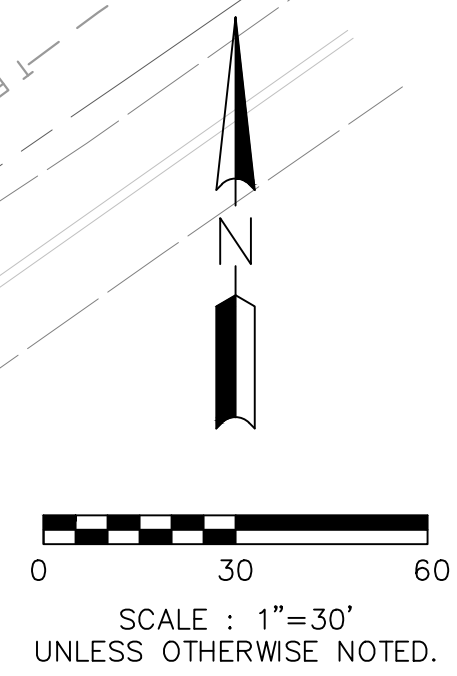
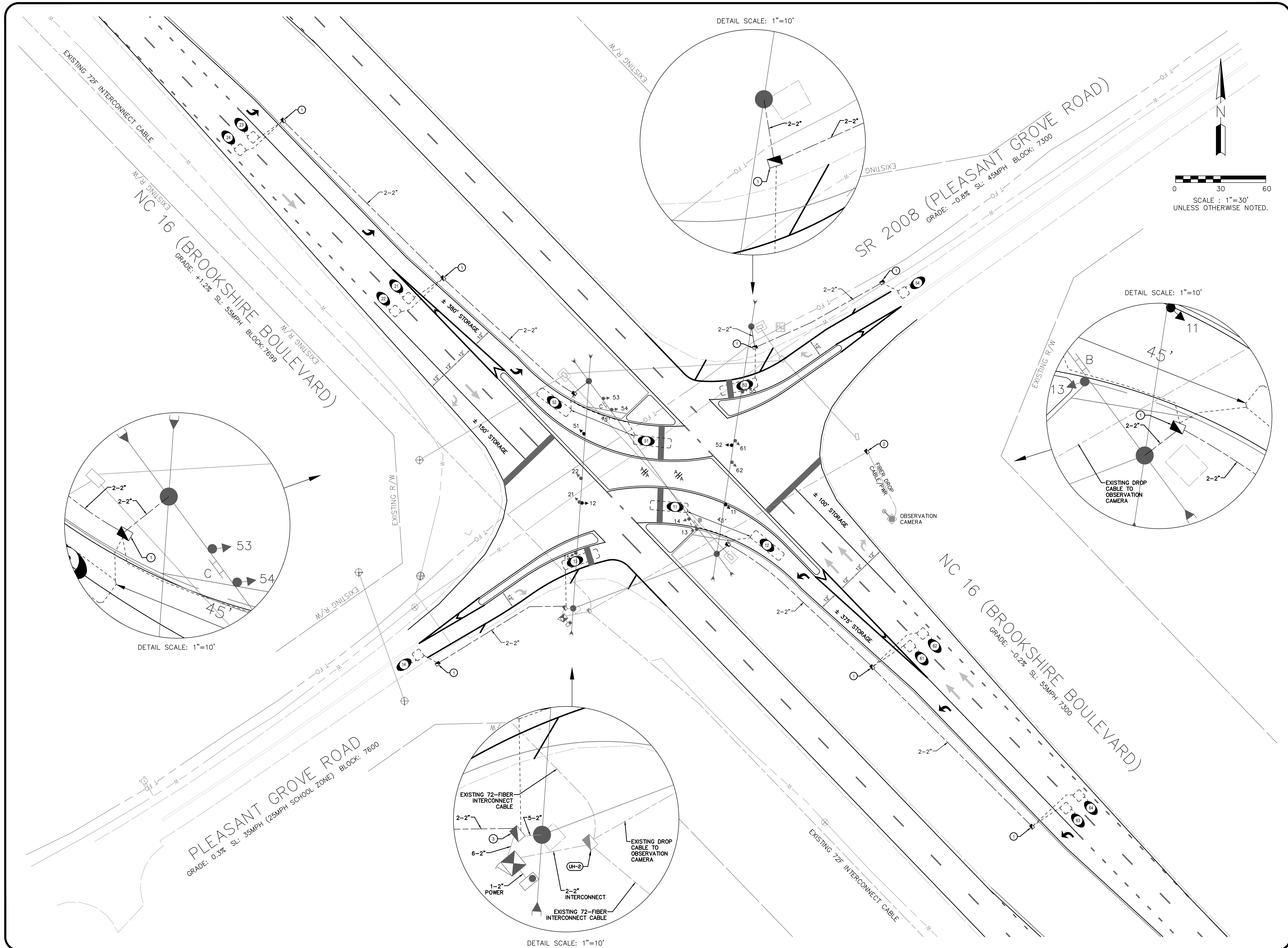

Plans Prepared For:
CITY OF CHARLOTTE
 DEPARTMENT OF
 TRANSPORTATION
 600 E. 7TH ST. CHARLOTTE, NC 28202
 704.252.4191 FAX: 704.336.4660

Plans Prepared By:
DRMP
 DRMP, Inc.
 8000 Regency Parkway, Suite 110
 Cary, NC 27513
 NC License No. C-2216 (919) 659-1038

NO.	DATE	BY	REVISION DESCRIPTION

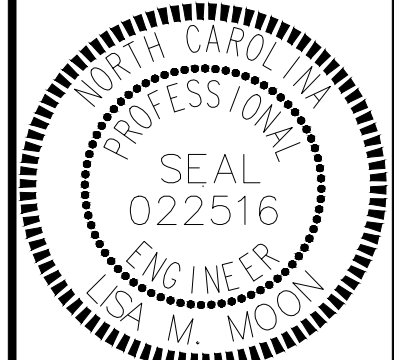

Designed by:
Lisa M. Moon 2/5/2022
SACR6808200421
 DOCUMENT NOT CONSIDERED FINAL UNLESS ALL SIGNATURES COMPLETED

W-5710AK JOB NO.	DJW PREPARED BY	03-2022 DATE
00940 SIGNAL NO.	10-0880 NCDOT ID NO.	L. MOON APPROVER

SHEET **SIG5.3** OF **SIG5.8**
NC 16 (BROOKSHIRE BLVD) @ PLEASANT GROVE RD
SIGNAL PLAN

SIGNAL PHASING

Ring Configuration 1,2,a,3,4,b,5,6,a,7,8,b

MIN RECALL

SIGNAL SEQUENCE

RING 1	PHASE 1	PHASE 2	PHASE 3	PHASE 4	FLASH
SIGNAL ID NUMBER	R/W OTH	R/W OTH	R/W OTH	R/W OTH	
11,12	▶	◀			
13,14,15	▶	◀			
21,22		G Y			

RING 2	PHASE 5	PHASE 6	PHASE 7	PHASE 8	FLASH
SIGNAL ID NUMBER	R/W OTH	R/W OTH	R/W OTH	R/W OTH	
51,52	▶	◀			
53,54,55	▶	◀			
61,62		G Y			

◀ RED ARROW ▶ YELLOW ARROW
▶ GREEN ARROW ✱ FLASHING YELLOW ARROW

OVERLAP PHASE

OVERLAP PHASE	OL-A/1+2 LT/FYA	OL-B/	OL-C/5+6 LT/FYA	OL-D/	FLASH
SIGNAL ID NUMBER	R/W OTH	R/W OTH	R/W OTH	R/W OTH	
11a,12a	✱	◀			
51a,52a			✱	◀	

OVERLAP PHASE	OL-E/	OL-F/	OL-G/	OL-H/	FLASH
SIGNAL ID NUMBER	R/W OTH	R/W OTH	R/W OTH	R/W OTH	

◀ RED ARROW ▶ YELLOW ARROW
▶ GREEN ARROW ✱ FLASHING YELLOW ARROW

TURNING MOVEMENT COUNT

NOT AVAILABLE

CLEARANCE INTERVALS

Phase	1	2	3	4	5	6	7	8
% Grade	-0.2%	1.2%			1.2%	-0.2%		
Distance	68	109			73	109		
Approach Speed (mph)	25	55			25	55		
Yellow	3.2	5.0			3.1	5.2		
All Red	1.9	1.4			2.0	1.4		
Total Clearance	5.1	6.4			5.1	6.6		

SIGN ID

A
R3-24
36" x 36"

NOTE: City will supply street name signs for installation

SIGNAL HEAD ID

11a, 12a, 51a, 52a
11a, 12a, 51a, 52a
11a, 12a, 51a, 52a
11, 12, 51, 52

21,22
61,62

13,14,15
53,54,55

MALFUNCTION MANAGEMENT UNIT / CONFLICT MONITOR

PROGRAMMING DETAIL

(program card and tables as shown)

FIELD CHECK ENABLE

CHANNEL NUMBER	ENABLE/DISABLE
1	ENABLE
2	ENABLE
3	DISABLE
4	DISABLE
5	ENABLE
6	ENABLE
7	DISABLE
8	DISABLE
9	DISABLE
10	DISABLE
11	DISABLE
12	DISABLE
13	ENABLE
14	DISABLE
15	ENABLE
16	DISABLE

ECONOLITE EOS-2070 SPECIAL MMU PROGRAMMING

(program controller as shown)

- From Main Menu select **1. CONFIGURATION**
- From CONFIGURATION Submenu select **1. CABINET**
- From PORT 1 (SDLC) Submenu select **4. MONITOR PROGRAMMING**

CAUTION!

Set intersection to Flash before attempting to enter or change any MMU programming data.

This programming and that of the MMU programming card must match exactly. If they do not, the intersection will be placed into Flash.

```

MMU PROGRAM [  MANUAL ]

CH  6 5 4 3 2 1 0 9 8 7 6 5 4 3 2
1  . X . X . . . . . X X . . .
2  . X . X . . . . . X X . . .
3  . . . . .
4  . . . . .
5  . X . X . . . . .
6  . X . X . . . . .
7  . . . . .
8  . . . . .
9  . . . . .
10 . . . . .
11 . . . . .
12 . . . . .
13 . X .
14 . .
15 .
  
```

END PROGRAMMING

UNIT OPTIONS

OPTION	SETTING
RECURRENT PULSE	ON
WALK DISABLE	OFF
LOG CVM FAULTS	ON
EXTERN WATCHDOG	OFF
24V-2=12VDC	OFF
PGM CARD MEMORY	ON
LEDguard	ON
FORCE TYPE 16	OFF
TYPE12-SDLC	OFF
VM 3xDay Latch	ON

FLASHING YELLOW ARROW

CONFIG MODE	B
ENABLE CHANNEL PAIR, FYA	
CH 1-13	ON
CH 3-14	OFF
CH 5-15	ON
CH 7-16	OFF
RED/YEL INPUT ENABLE	
CH 1	ON
CH 3	OFF
CH 5	ON
CH 7	OFF
FLASH RATE FAULT	ON
FYA TRAP DETECT	ON

MMU PROGRAMMING NOTE
ENSURE YELLOW CHANGE PLUS RED CLEARANCE MONITORING IS ENABLED FOR ALL CHANNELS.

DETECTOR RACK SETUP

INSERT DETECTOR CARDS IN RACK ACCORDING TO THE DETAIL SHOWN BELOW. PARTICULAR DETECTOR CHANNELS WILL CALL PHASES INDICATED.

DET BIU #1	CH3	CH1	CH3	CH1	CH3	CH1	CH3	CH1	SLOT	SLOT	SLOT	SLOT	DET BIU #2
L3	L1	L7	L5	L11	L9	L15	L13		S	S	S	S	
∅1	∅1	∅2	∅2	∅5	∅5	∅6	∅6		E	E	E	E	
13	11	23	21	53	51	63	61		M	M	M	M	
CH4	CH2	CH4	CH2	CH4	CH2	CH4	CH2						
L4	L2	L8	L6	L12	L10	L16	L14						
∅1	∅1	∅2	∅2	∅5	∅5	∅6	∅6						
14	12	24	22	54	52	64	62						

APS PUSH BUTTON INPUT SETUP

W-5710AK JOB NO.	DJW PREPARED BY	03-2022 DATE
00940 SIGNAL NO.	10-0880 NCDOT ID NO.	L. MOON APPROVER

NC 16 (BROOKSHIRE BLVD) @ PLEASANT GROVE RD

SIGNAL DETAILS

SHEET **SIG5.4** OF **SIG5.8**

CITY OF CHARLOTTE
DEPARTMENT OF TRANSPORTATION
704.259.4191 FAX: 704.336.4660

Plans Prepared For:

DRMP, Inc.
8000 Regency Parkway, Suite 110
Charlotte, NC 28226
NC License No. C-2216 (919) 659-1038

REVISION DESCRIPTION

NO.	DATE	BY

Disseminated by:
Lisa M. Moon
3/25/2022
DOCUMENT NOT CONSIDERED FINAL UNLESS ALL SIGNATURES COMPLETED

LEGEND

- EXISTING SPLICE
- NEW SPLICE

ALL UNUSED FIBERS ARE TO BE EXPRESSED THROUGH.

SPLICE 00940

STUB TO BROOKSHIRE BLVD/
PLEASANT GROVE ROAD
CAMERA CONTROL BOX
CCTV #1281

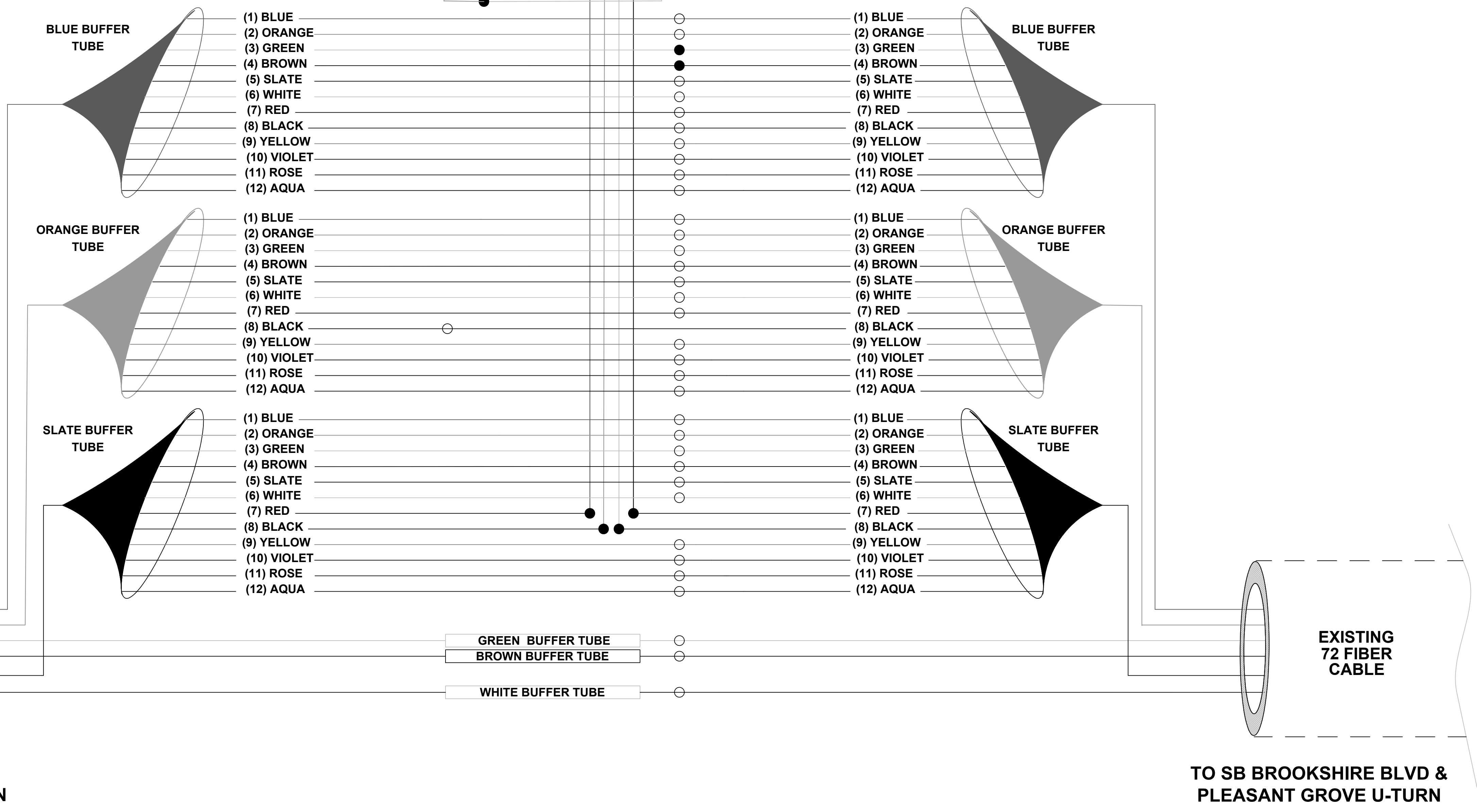
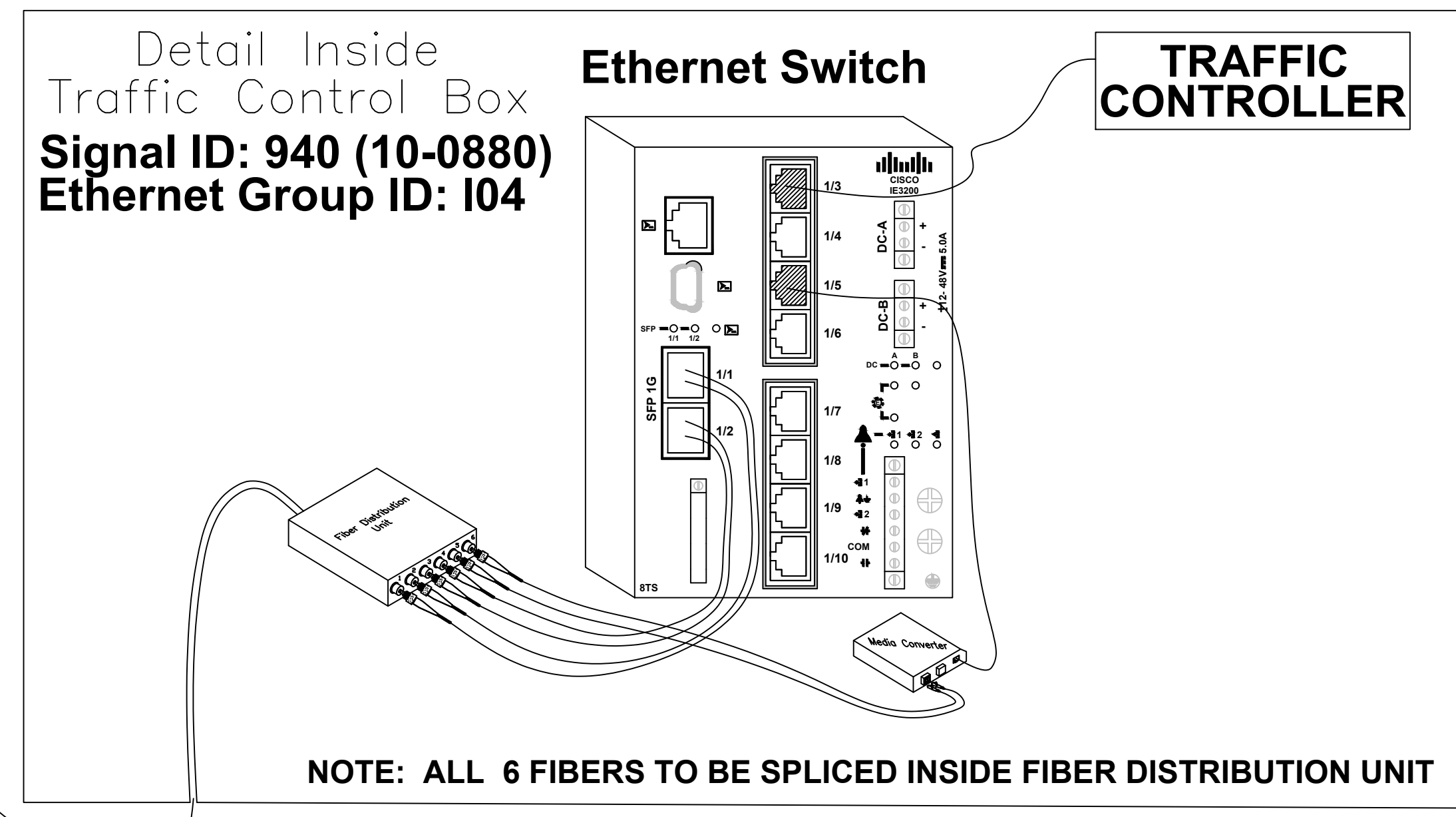
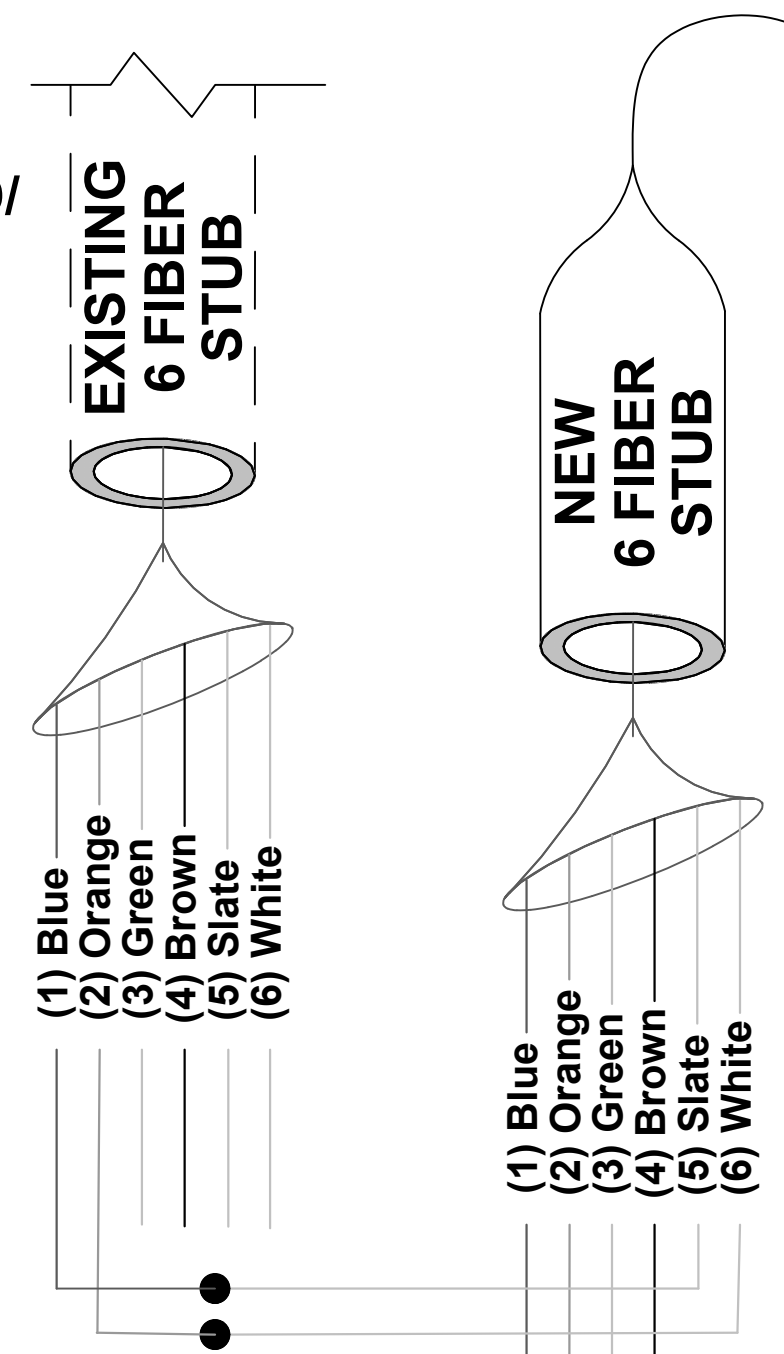

FROM NB BROOKSHIRE BLVD &
PLEASANT GROVE ROAD U-TURN

TO SB BROOKSHIRE BLVD &
PLEASANT GROVE U-TURN

SPLICE CASE IN HANDHOLE# 16 ON BROOKSHIRE BLVD AT PLEASANT GROVE ROAD



Plans Prepared For:
CITY OF CHARLOTTE
DEPARTMENT OF
TRANSPORTATION
600 E. 4TH ST. FLOOR 1100
CHARLOTTE, NC 28202
704.259.4191 FAX: 704.336.4660

Plans Prepared By:
DRMP
DRMP, Inc.
8000 Regency Parkway, Suite 110
Charlotte, NC 28226
NC License No. C-2216 (919) 659-1038

NO.	DATE	BY	REVISION DESCRIPTION



Designed by
Lisa M. Moon
3/25/2022

00940	W-5710AK	03-2022
SIGNAL NO.	JOB NO.	DATE
10-0880	DJW	PREPARED BY
NCDOT ID NO.	L. MOON	APPROVER

NC 16 (BROOKSHIRE BLVD)
@ PLEASANT GROVE RD

FIBER OPTIC
SPLICE DETAILS

SHEET
SIG5.5

OF
SIG5.8

SIGNAL HEAD WIRING

CHANNEL		SIGNAL HEAD HOOK UP CHART																												
PHASE		1				2		3	4	5				6		7	8	9	10	11	12	13		14	15		16			
SIGNAL HEAD NO.		11★	12★	14	13	15	22	21	NU	NU	51★	52★	54	53	55	61	62	NU	NU	NU	NU	NU	NU	11a★	12a★	NU	51a★	52a★	NU	
RED	Wire			14R	13R	15R	22R	21R					54R	53R	55R	61R	62R													
	Terminal			LS1-R	[14R]	LS1-R	LS2-R	[22R]					LS5-R	[54R]	LS5-R	LS6-R	[61R]													
YELLOW	Wire	*	*				22Y	21Y			*	*				61Y	62Y													
	Terminal						LS2-Y	[22Y]								LS6-Y	[61Y]													
GREEN	Wire						22G	21G								61G	62G													
	Terminal						LS2-G	[22G]								LS6-G	[61G]													
RED ARROW	Wire																													
	Terminal																													
YELLOW ARROW	Wire			14YS	13YS	15YS							54YS	53YS	55YS															
	Terminal			LS1-Y	[14Y]	LS1-Y							LS5-Y	[54Y]	LS5-Y															
FLASHING YELLOW	Wire																													
	Terminal																													
GREEN ARROW	Wire	11GS	12GS	14GS	13GS	15GS				51GS	52GS	54GS	53GS	55GS																
	Terminal	LS1-G	LS1-G	LS1-G	[14G]	LS1-G				LS5-G	LS5-G	LS5-G	[54G]	LS5-G																

[XX*] = TERMINAL BLOCK IN SIGNAL HEAD | LSX* = TERMINAL IN LOAD BAY * Denotes install load resistor. See Load Resistor Detail on this sheet. See pictorial of head wiring detail on this sheet. NU = NOT USED

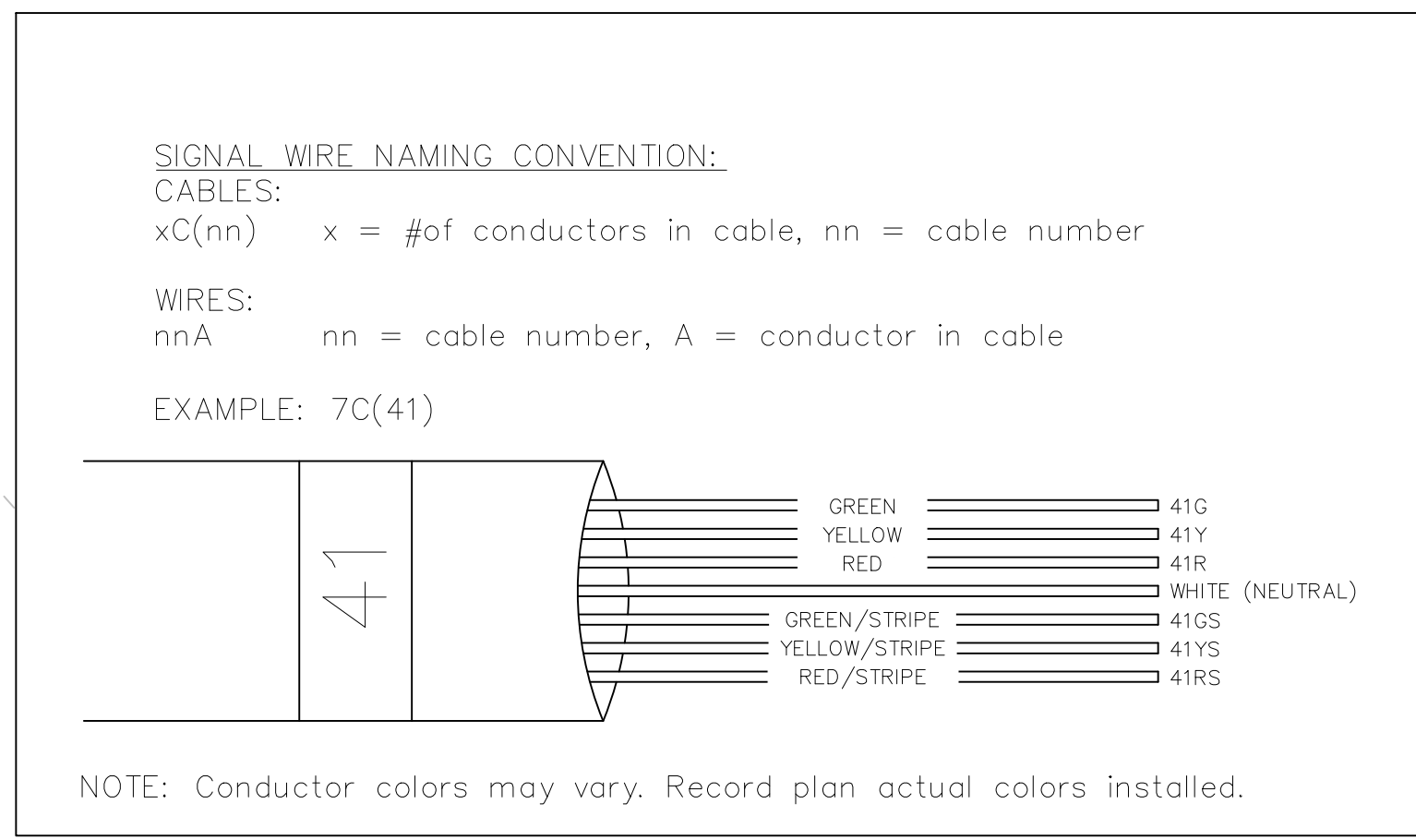
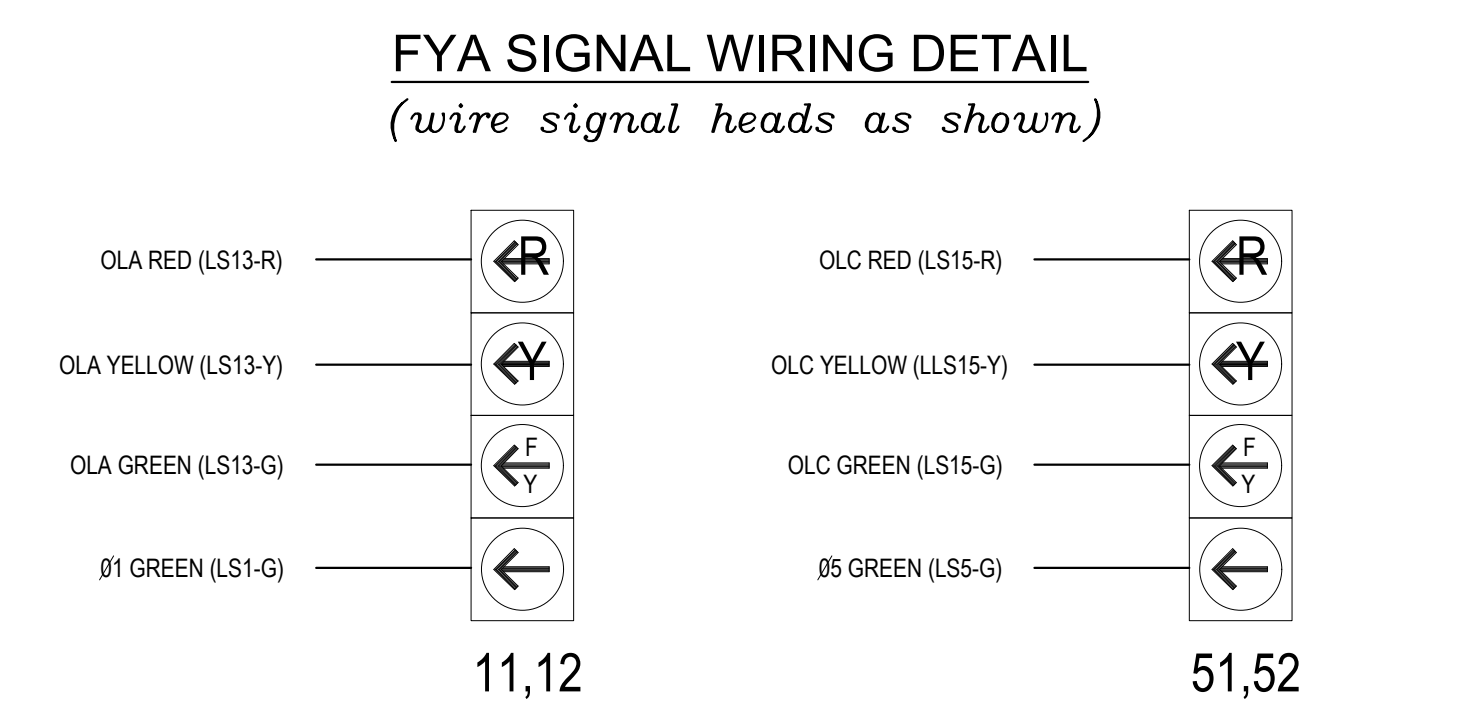
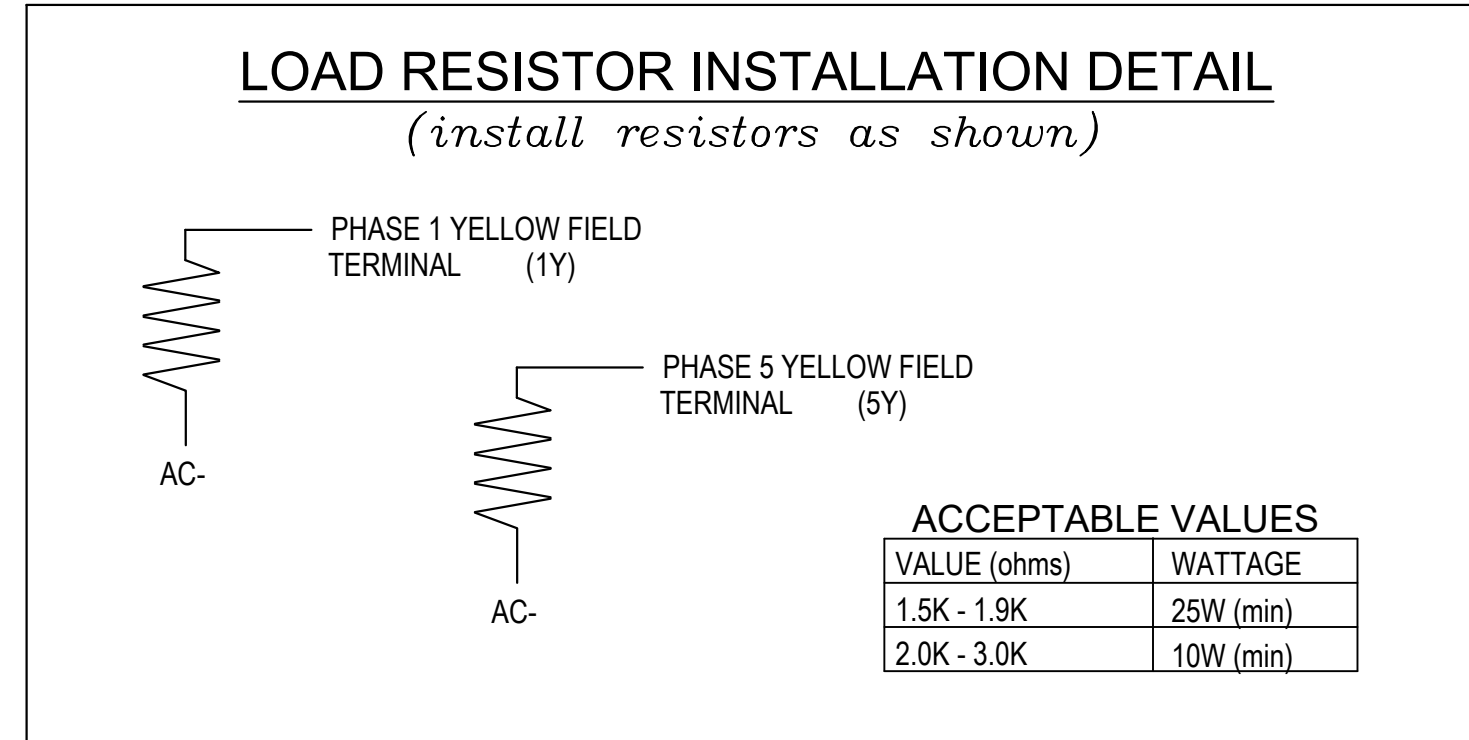
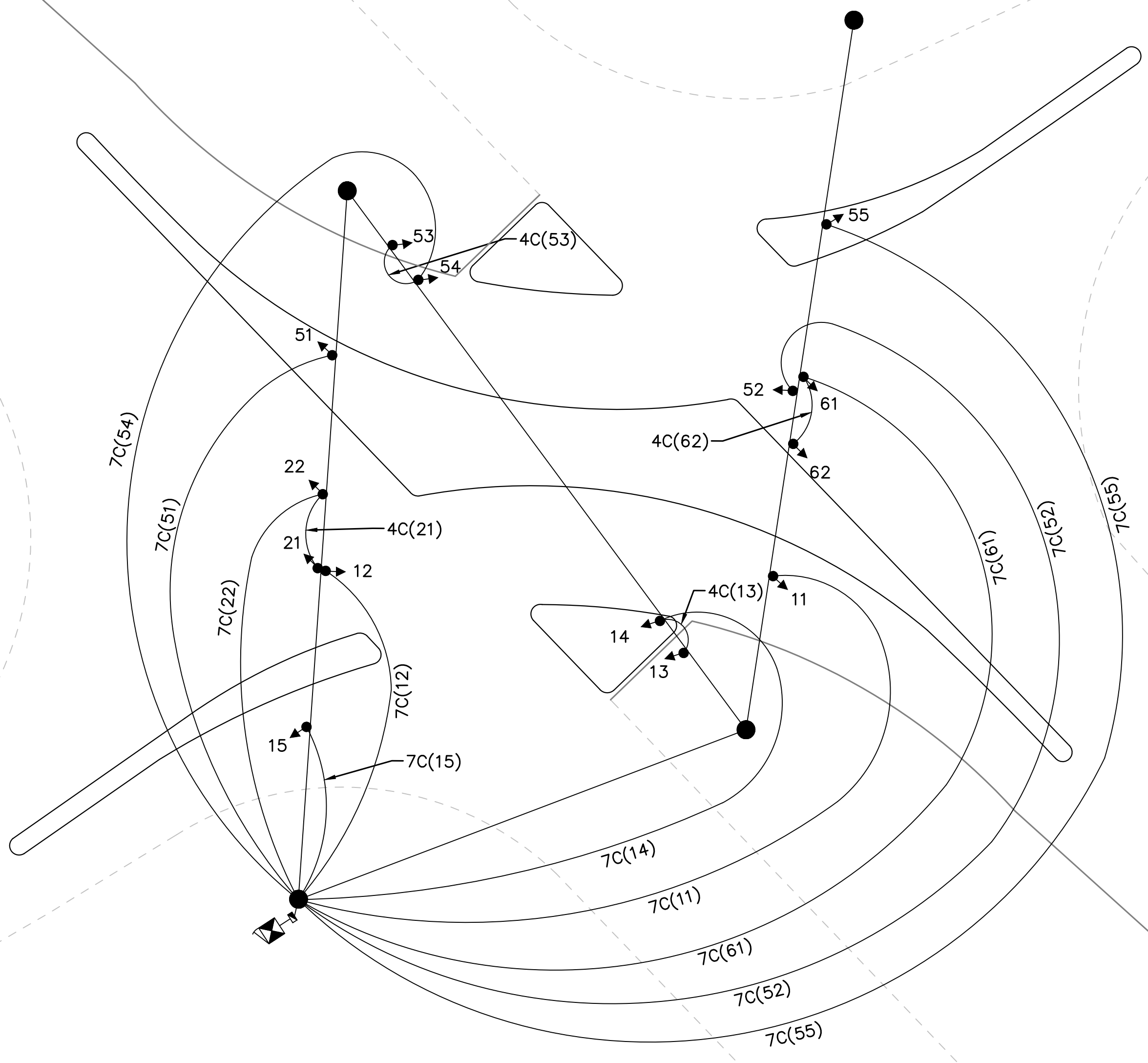

NOTE: Conductor colors may vary. Record plan actual colors installed.



Plans Prepared For:
CITY OF CHARLOTTE
 DEPARTMENT OF
 TRANSPORTATION
 600 E. 4TH ST. FLOOR 1100
 CHARLOTTE, NC 28202
 704-654-4100 FAX 704-359-4600

Plans Prepared By:
DRMP
 DRMP, Inc.
 8000 Regency Parkway, Suite 110
 Charlotte, NC 28226
 NC License No. C-2216 (919) 859-0088

NO	DATE	BY	REVISION DESCRIPTION

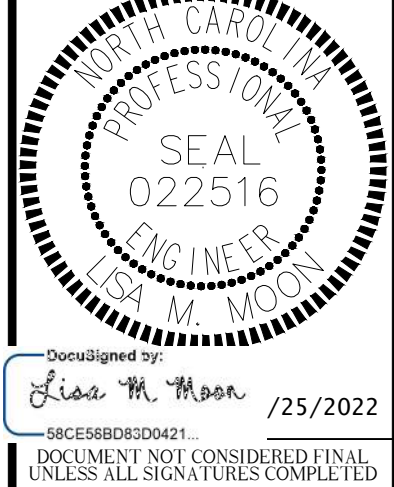

Designed by: *Lisa M. Moon* /25/2022
 PROJECT: 00940-00841
 DOCUMENT NOT CONSIDERED FINAL UNLESS ALL SIGNATURES COMPLETED

W-5710AK	JOB NO.	DJW	PREPARED BY	03-2022	DATE
00940	SIGNAL NO.	10-0880	NC DOT ID NO.	L. MOON	APPROVER

SHEET
SIG5.6
 OF
SIG5.8

NC 16 (BROOKSHIRE BLVD)
 @ PLEASANT GROVE RD

SIGNAL WIRING DIAGRAM

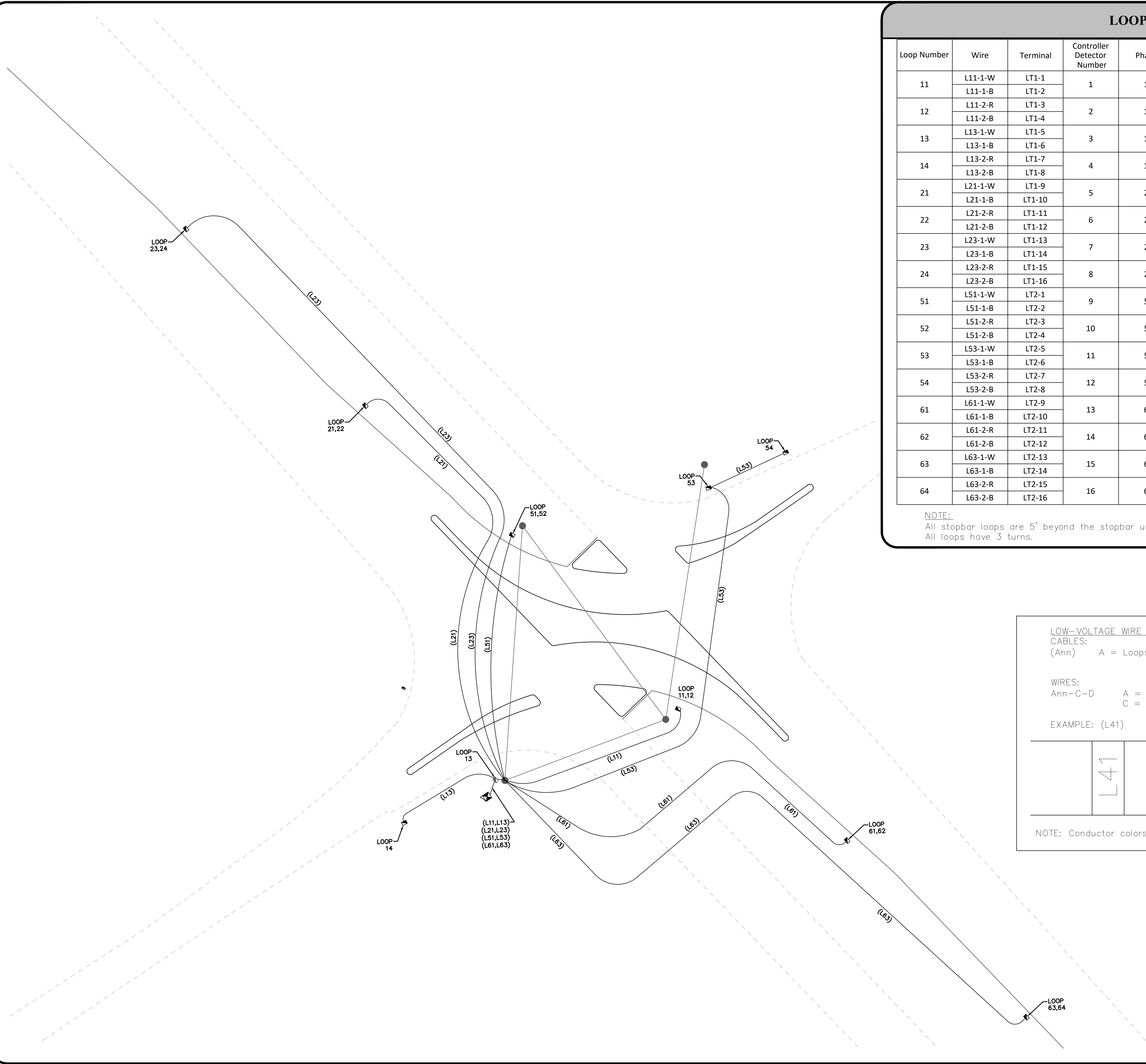

LOOP WIRING

Loop Number	Wire	Terminal	Controller Detector Number	Phase	Timing		Size	Comments
					Feature	Time (sec)		
11	L11-1-W	LT1-1	1	1	-	-	6'X25'	@ STOP BAR
	L11-1-B	LT1-2						
12	L11-2-R	LT1-3	2	1	-	-	6'X25'	65' FROM STOP BAR
	L11-2-B	LT1-4						
13	L13-1-W	LT1-5	3	1	DELAY	15	6'X25'	@STOP BAR
	L13-1-B	LT1-6						
14	L13-2-R	LT1-7	4	1	-	-	6'X6'	130' FROM STOP BAR
	L13-2-B	LT1-8						
21	L21-1-W	LT1-9	5	2	-	-	6'X6'	130' FROM STOP BAR
	L21-1-B	LT1-10						
22	L21-2-R	LT1-11	6	2	-	-	6'X6'	130' FROM STOP BAR
	L21-2-B	LT1-12						
23	L23-1-W	LT1-13	7	2	-	-	6'X6'	280' FROM STOP BAR
	L23-1-B	LT1-14						
24	L23-2-R	LT1-15	8	2	-	-	6'X6'	280' FROM STOP BAR
	L23-2-B	LT1-16						
51	L51-1-W	LT2-1	9	5	-	-	6'X25'	@ STOP BAR
	L51-1-B	LT2-2						
52	L51-2-R	LT2-3	10	5	-	-	6'X25'	65' FROM STOP BAR
	L51-2-B	LT2-4						
53	L53-1-W	LT2-5	11	5	DELAY	15	6'X25'	@STOP BAR
	L53-1-B	LT2-6						
54	L53-2-R	LT2-7	12	5	-	-	6'X25'	130' FROM STOP BAR
	L53-2-B	LT2-8						
61	L61-1-W	LT2-9	13	6	-	-	6'X6'	130' FROM STOP BAR
	L61-1-B	LT2-10						
62	L61-2-R	LT2-11	14	6	-	-	6'X6'	130' FROM STOP BAR
	L61-2-B	LT2-12						
63	L63-1-W	LT2-13	15	6	-	-	6'X6'	280' FROM STOP BAR
	L63-1-B	LT2-14						
64	L63-2-R	LT2-15	16	6	-	-	6'X6'	280' FROM STOP BAR
	L63-2-B	LT2-16						

NOTE:
 All stopbar loops are 5' beyond the stopbar unless otherwise noted.
 All loops have 3 turns.

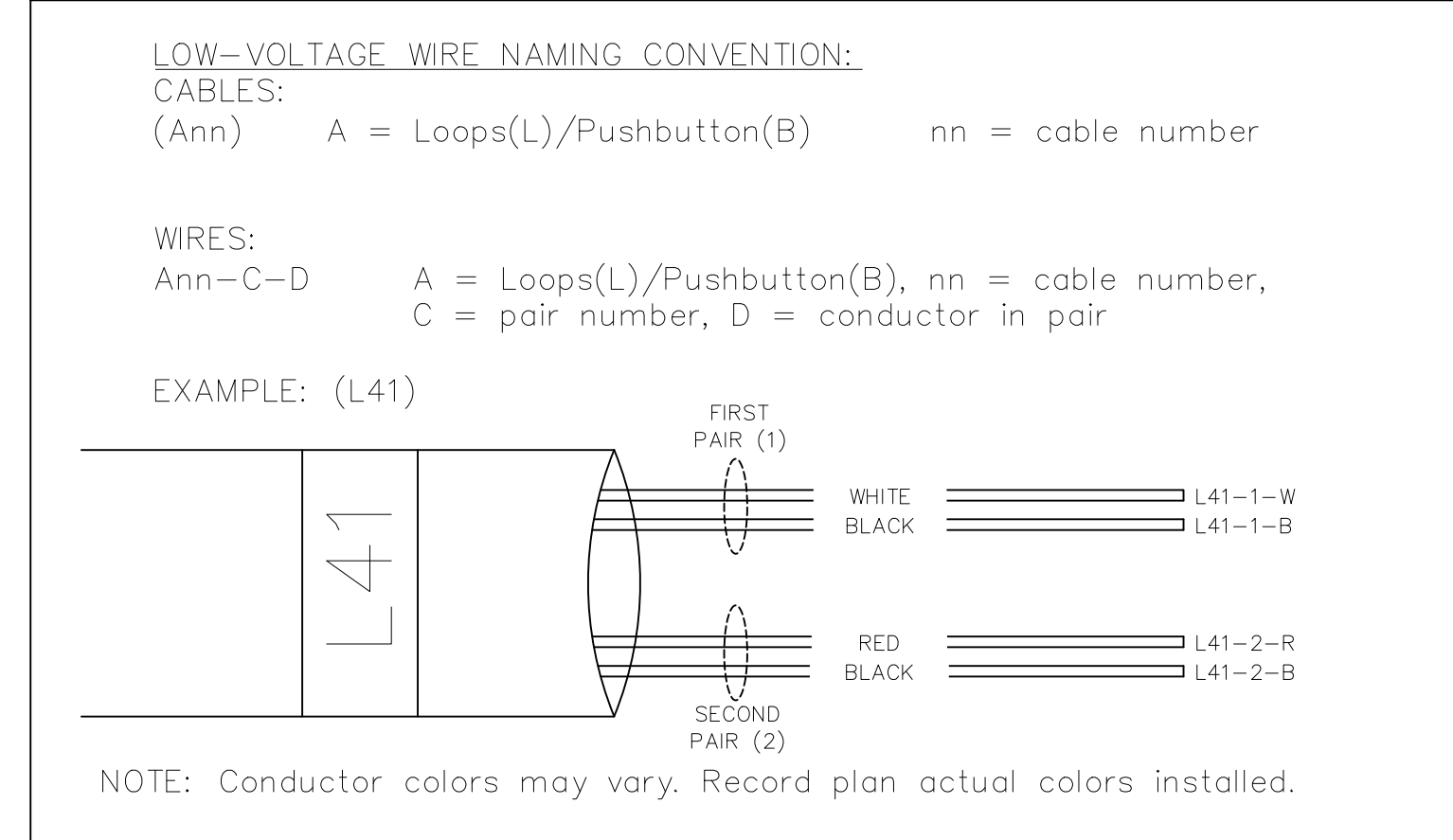

NOTE

CDOT TO PROGRAM DETECTOR TYPES AND TIMERS (EXTEND AND DELAY) AS SHOWN IN LOOP WIRING CHART ABOVE INTO CONTROLLER



Plans Prepared For:
CITY OF CHARLOTTE
 DEPARTMENT OF TRANSPORTATION
 600 E. 4TH ST. FLOOR 2100, CHARLOTTE, NC 28202
 704.259.4191 FAX: 704.336.4660

Plans Prepared By:
DRMP
 DRMP, Inc.
 8000 Regency Parkway, Suite 110
 Cary, NC 27513
 NC License No. C-2216 (919) 659-1038

NO.	DATE	BY	REVISION DESCRIPTION

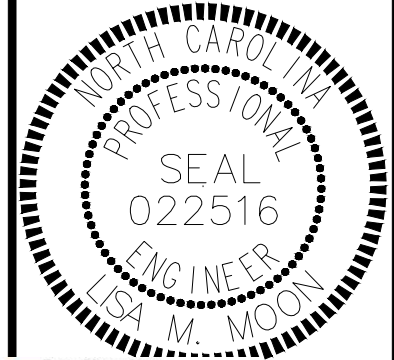

Designed by: *Lisa M. Moon*
 3/25/2022
 58C5E8B08D0421

DOCUMENT NOT CONSIDERED FINAL UNLESS ALL SIGNATURES COMPLETED

W-5710AK JOB NO.	DJM PREPARED BY	03-2022 DATE
00940 SIGNAL NO.	10-0880 NCDOT ID NO.	L. MOON APPROVER

**NC 16 (BROOKSHIRE BLVD)
 @ PLEASANT GROVE RD**

**LOW VOLTAGE
 WIRING DIAGRAM**

SHEET **SIG5.7** OF **SIG5.8**

NOTE:
 ALL LEAD-IN WIRE SHOULD BE TWO PAIR CABLE

NOTES

1. To prevent "flash-conflict" problems, wire all unused load switches to flash red. Verify that signal heads flash in accordance with the signal plans.
2. To prevent red failures on unused monitor channels, tie unused load switch red outputs 3, 4, 7, 8, 9, 10, 11, 12, 14 and 16 to load switch AC+ by inserting a jumper plug in the unused load switch socket from pin 1 (LS AC+) to pin 3 (RED out). Make sure all flash transfer relays are in place.
- ◆ 3. Program controller to start up in phase 2 Green and 6 Green.
- ◆ 4. Set power-up flash time to 12 seconds and implement on the Malfunction Management Unit. Set controller power-up flash time to 22 seconds.
- ◆ 5. Program detectors in accordance with the manufacturer's instructions to accomplish the detection schemes shown on the signal design plans.
- ◆ 6. Program detector call delay and extension timing on the controller, unless otherwise specified.
7. Set all detector card unit channels to "presence" mode.
8. The cabinet and controller are a part of the Charlotte Signal System.

EQUIPMENT INFORMATION

CONTROLLER.....2070LX
 CABINETTS-2
 SOFTWAREECONOLITE EOS-2070
 CABINET MOUNT.....BASE
 LOADBAY POSITIONS.....16
 LOAD SWITCHES USED.....1,2,5,6,13,15
 PHASES USED.....1,2,5,6
 OLA.....1+2
 OLB.....NOT USED
 OLC.....5+6
 OLD.....NOT USED

◆ Software and Programming by CDOT

City of Charlotte Department of Transportation (CDOT) to provide EOS Software and do all Programming of the controller database. Contractor to provide CDOT with controller for programming a minimum of two weeks prior to installation. CDOT will return controller, fully programmed for contractor to install and integrate into the controller cabinet.



Plans Prepared For:
 CITY OF CHARLOTTE
 DEPARTMENT OF
 TRANSPORTATION
 600 E. 4TH ST. CHARLOTTE, NC 28202
 PH: 352-4191 FAX: 704-358-4660

Plans Prepared By:

 DRMP, Inc.
 8000 Regency Parkway, Suite 110
 Cary, NC 27513
 NC License No. C-2216 (919) 659-1038

NO.	DATE	BY	REVISION DESCRIPTION



Designed by:
Lisa M. Moon /25/2022
NCES6803000421

DOCUMENT NOT CONSIDERED FINAL UNLESS ALL SIGNATURES COMPLETED

W-5710AK JOB NO.	DJM PREPARED BY	03-2022 DATE
---------------------	--------------------	-----------------

00940 SIGNAL NO.	10-0880 NCDOT ID NO.	L. MOON APPROVER
---------------------	-------------------------	---------------------

NC 16 (BROOKSHIRE BLVD)
 @ PLEASANT GROVE RD
 MISCELLANEOUS
 DETAILS

SHEET
SIG5.8
 OF
SIG5.8

Signal ID 01907/ NCDOT 10-2400

NC 16 (Brookshire Blvd) SB @ Pleasant Grove Rd U-Turn

INDEX OF SHEETS	
Cover Sheet	SIG6.0
Signal Plan	SIG6.1
Signal Details	SIG6.2
Splice Detail	SIG6.3
Signal Wiring Diagram	SIG6.4
Low Voltage Wiring Diagram	SIG6.5
Miscellaneous Details	SIG6.6
TOTAL SHEETS 7	

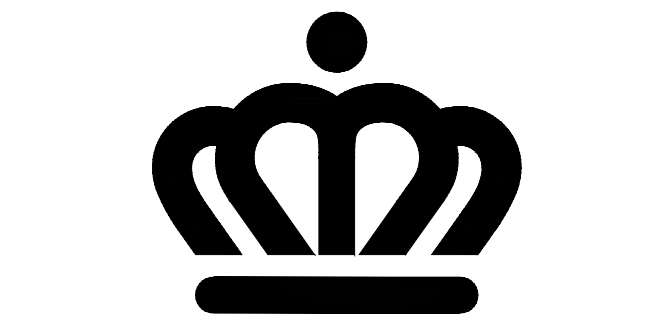
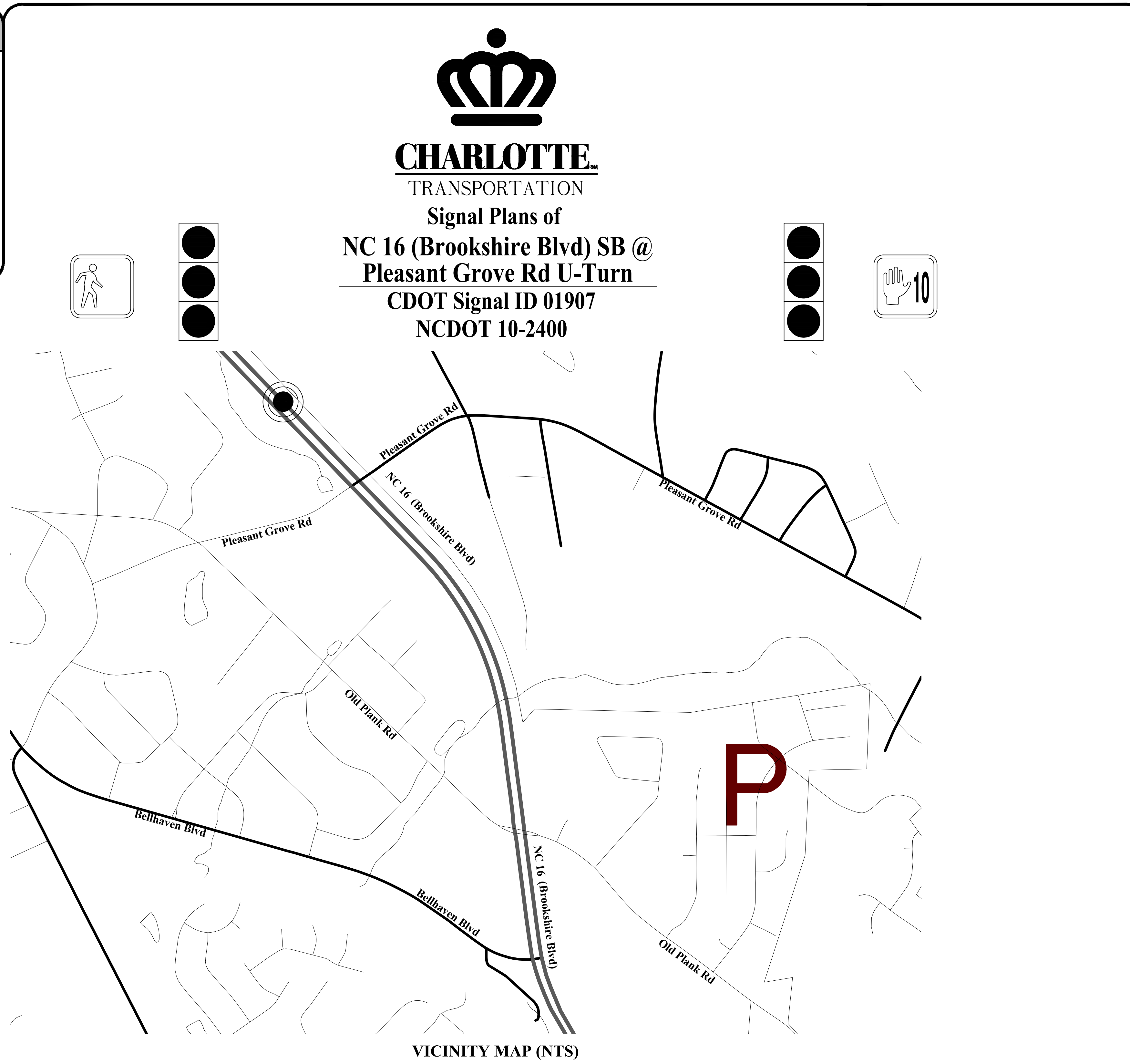

CHARLOTTE
TRANSPORTATION
Signal Plans of
**NC 16 (Brookshire Blvd) SB @
Pleasant Grove Rd U-Turn**
CDOT Signal ID 01907
NCDOT 10-2400

VICINITY MAP (NTS)

LEGEND		
PROPOSED	DESCRIPTION	EXISTING
	CONTROL BOX	
	METER PEDESTAL	
	PULL BOX	
	STEEL POLE	
	MAST ARM	
	PED PEDESTAL	
	UTILITY POLE	
	ANCHOR	
	SIGNAL HEAD	
	VIDEO CAMERA	
	OPTICOM	
	OBSERVATION CAM	
	DETECTOR	
	CONDUIT	
	INTERCONNECT	
	EDGE OF PVMT.	
	CURB & GUTTER	
	TUBULAR MARKER	
	GROUND SIGN	
	OVERHEAD SIGN	
	DOUBLE YELLOW	
	STOP BAR	
	WHITE SKIP	
	WHITE MINI	
	PAVEMENT ARROW	
	PROPERTY LINE	
	ROW	
	UTILITIES TELEPHONE UG CABLE SUE	
	UTILITIES SANITARY SEWER UG LINE	
	UTILITIES WATER UG LINE SUE	
	UTILITIES GAS UG LINE SUE	
	UTILITIES TELEPHONE UG FO SUE	
	OTHER CULTURE FENCE LINE	

PULLBOX ID		
	SIZE	PULLBOX TYPE
①	13"x24"x12"	LOOP
②	17"x30"x30"	FIBER OPTIC
③	24"x36"x24"	CONTROLLER / FIBER
④	30"x48"x36"	CONTROLLER
⑤	24"x24"x12"	CONTROLLER
UH-2	24"x36"x30"	FIBER SPLICE

NOTE:
PULLBOX MATERIAL MUST MEET OR EXCEED THE 2018 NCDOT STANDARD TRAFFIC SIGNAL SPECIFICATIONS.

PLANS PREPARED FOR:

City of Charlotte
Department of Transportation
600 East 4th Street Charlotte, NC 28202
Phone: (704) 336-4119
Fax: (704) 336-4400

PLAN NOTES

- ALL PAVEMENT MARKING DIMENSIONS ARE APPROXIMATE.
- SIGNAL SHALL BE INSTALLED IN ACCORDANCE WITH THE LATEST NCDOT STANDARD SPECIFICATIONS AND PROJECT SPECIAL PROVISIONS.
- CITY WILL SUPPLY STREET NAME SIGNS FOR INSTALLATION.
- SEE SIGNAL COMMUNICATION PLANS FOR CONSTRUCTION RELATED TO SYSTEM, SHOWN ON SIGNAL PLANS AS EXISTING.
- ATTACHMENT HEIGHTS ARE ESTIMATED, BASED ON AVAILABLE INFORMATION AND EXISTING SURVEY ELEVATIONS. CONTRACTOR SHALL FIELD VERIFY ELEVATIONS TO ENSURE POLES OF SUFFICIENT LENGTH TO MAINTAIN MINIMUM REQUIRED CLEARANCE ABOVE THE ROADWAY.

PE SEAL

DRMP, Inc.
8000 Regency Parkway, Suite 110
Cary, NC 27518
NC License No. C-2213 (919) 650-1038

PROJECT TEAM

DESIGNER:	D. White
PROJECT ENGINEER:	C. Silver
PROJECT MANAGER:	L. Moon

Prepared for the Offices of:

750 N. Greenfield Pkwy,
Garner, NC 27529

SHEET
SIG6.0



Plans Prepared For:
CITY OF CHARLOTTE
 DEPARTMENT OF
 TRANSPORTATION
 600 E. 4TH ST. FLOOR 2100
 CHARLOTTE, NC 28202
 704.259.4191 FAX: 704.336.4660

Plans Prepared By:
DRMP
 DRMP, Inc.
 8000 Regency Parkway, Suite 110
 Cary, NC 27513
 919.859.1088
 NC License No. C-2216 (919) 859-4660

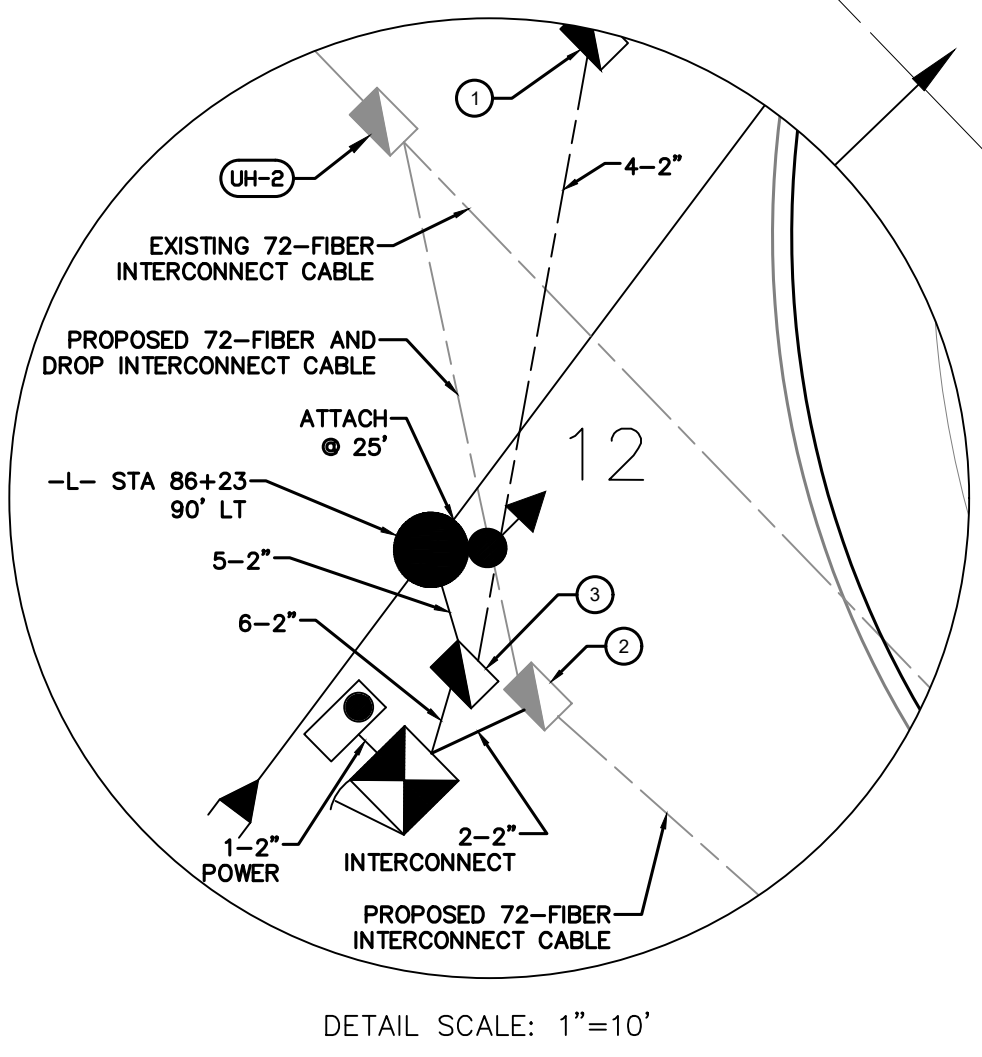
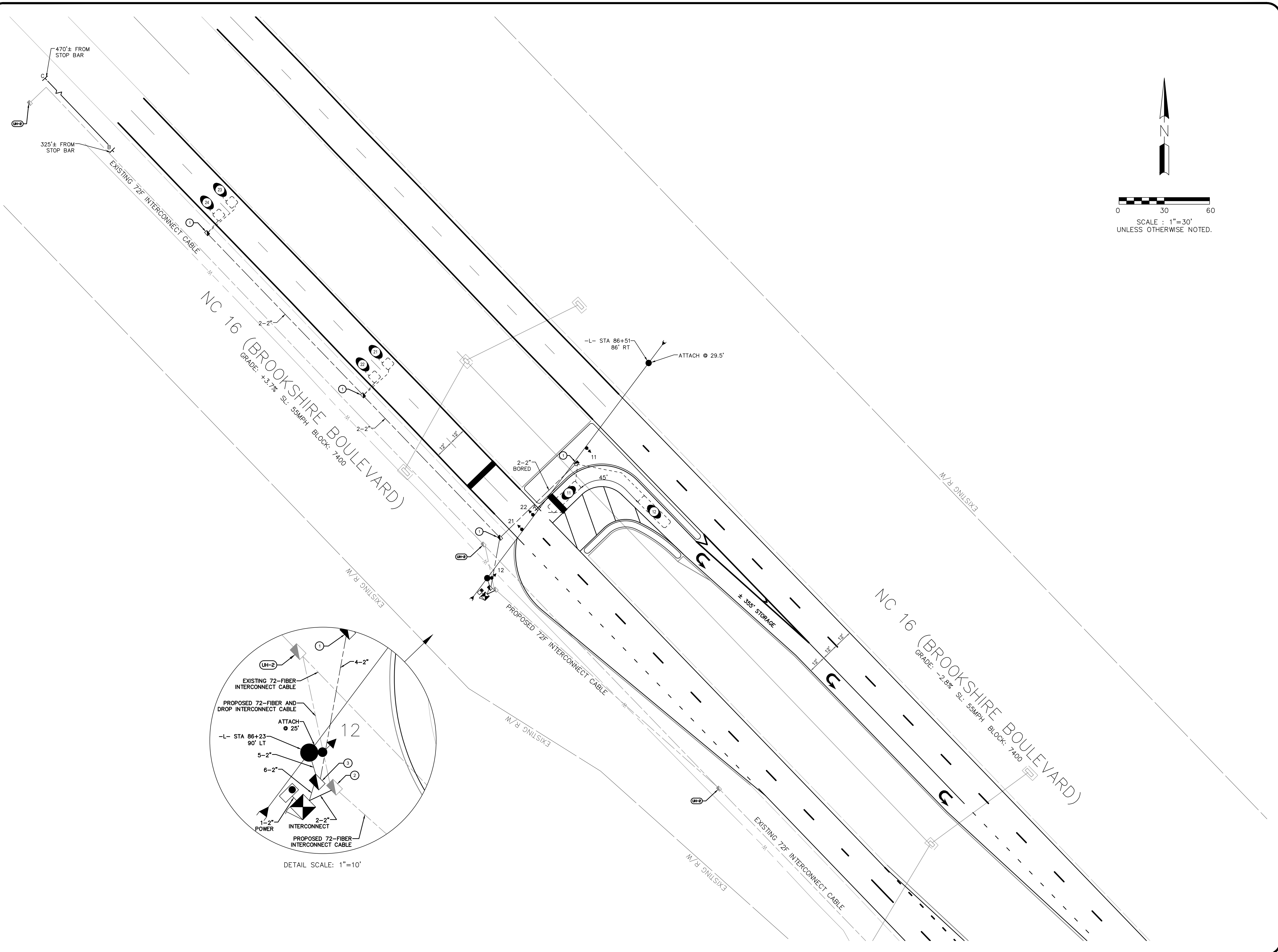
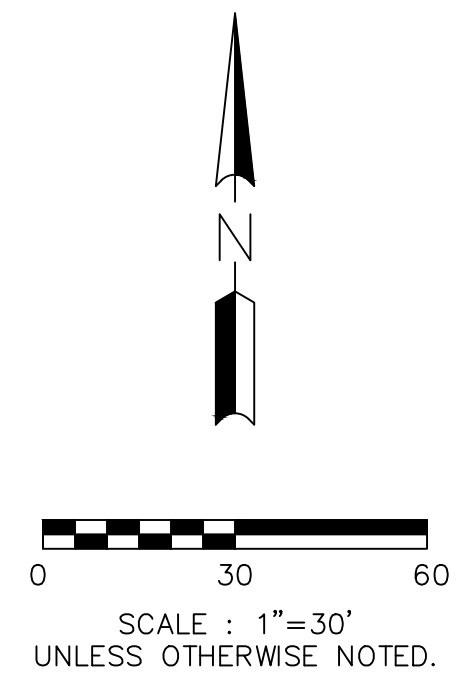

NO.	DATE	BY	REVISION DESCRIPTION



Designed by
 Lisa M. Moon 3/25/2022
 58265808300421

DOCUMENT NOT CONSIDERED FINAL UNLESS ALL SIGNATURES COMPLETED

W-5710AK JOB NO.	DJW PREPARED BY	03-2022 DATE
01907 SIGNAL NO.	10-2400 NCDOT ID NO.	L. MOON APPROVER

NC 16 (BROOKSHIRE BLVD) SB @ PLEASANT GROVE RD U-TURN

SHEET
SIG6.1
 OF
SIG6.6

SIGNAL PLAN

SIGNAL PHASING

Ring Configuration 1,2,3,4,5,6,7,8

1 NOT USED

2 NOT USED

3 NOT USED

4 NOT USED

5 NOT USED

6 NOT USED

7 NOT USED

8 NOT USED

MIN RECALL

b

SIGNAL SEQUENCE

RING 1	PHASE 1	PHASE 2	PHASE 3	PHASE 4	FLASH				
SIGNAL ID NUMBER	R/W	OTH	R/W	OTH	R/W	OTH	R/W	OTH	FLASH
11,12	◀	◀							Y
21,22			G	Y					

RING 2	PHASE 5	PHASE 6	PHASE 7	PHASE 8	FLASH				
SIGNAL ID NUMBER	R/W	OTH	R/W	OTH	R/W	OTH	R/W	OTH	FLASH

◀ RED ARROW ◀ YELLOW ARROW
 ◀ GREEN ARROW ✨ FLASHING YELLOW ARROW

OVERLAP PHASE

OVERLAP PHASE	OL-A/	OL-B/	OL-C/	OL-D/	FLASH				
SIGNAL ID NUMBER	R/W	OTH	R/W	OTH	R/W	OTH	R/W	OTH	FLASH

OVERLAP PHASE	OL-E/	OL-F/	OL-G/	OL-H/	FLASH				
SIGNAL ID NUMBER	R/W	OTH	R/W	OTH	R/W	OTH	R/W	OTH	FLASH

◀ RED ARROW ◀ YELLOW ARROW
 ◀ GREEN ARROW ✨ FLASHING YELLOW ARROW

TURNING MOVEMENT COUNT

NOT AVAILABLE

CLEARANCE INTERVALS

Phase	1	2	3	4	5	6	7	8
% Grade	-2.8%	3.7%						
Distance	61	81						
Approach Speed (mph)	15	55						
Yellow	3.0	4.8						
All Red	2.8	1.1						
Total Clearance	5.8	5.9						

SIGN ID

A R3-2 36" x 36"

B W3-3 36" x 36"

C W3-4 36" x 36"

SIGNAL HEAD ID

21,22

11

12

MALFUNCTION MANAGEMENT UNIT / CONFLICT MONITOR

PROGRAMMING DETAIL

(program card and tables as shown)

FIELD CHECK ENABLE
 DUAL IND ENABLE
 RED FAIL ENABLE

CHANNEL NUMBER	ENABLE/DISABLE
1	ENABLE
2	ENABLE
3	DISABLE
4	DISABLE
5	DISABLE
6	DISABLE
7	DISABLE
8	DISABLE
9	DISABLE
10	DISABLE
11	DISABLE
12	DISABLE
13	DISABLE
14	DISABLE
15	DISABLE
16	DISABLE

ECONOLITE EOS-2070 SPECIAL MMU PROGRAMMING

(program controller as shown)

- From Main Menu select 1. CONFIGURATION
- From CONFIGURATION Submenu select 1. CABINET
- From PORT 1 (SDLC) Submenu select 4. MONITOR PROGRAMMING

CAUTION!
 Set intersection to Flash before attempting to enter or change any MMU programming data.
 This programming and that of the MMU programming card must match exactly. If they do not, the intersection will be placed into Flash.

MMU PROGRAM [MANUAL]	CH	6	5	4	3	2	1	0	9	8	7	6	5	4	3	2
1															
2															
3															
4															
5															
6															
7															
8															
9															
10															
11															
12															
13															
14															
15															

END PROGRAMMING

UNIT OPTIONS	
OPTION	SETTING
RECURRENT PULSE	ON
WALK DISABLE	OFF
LDG CVM FAULTS	ON
EXTERN WATCHDOG	OFF
24V-2-12VDC	OFF
PGM CARD MEMORY	ON
LEDguard	ON
FORCE TYPE 16	OFF
TYPE12-SDLC	OFF
VM 3xDay Latch	ON

FLASHING YELLOW ARROW	
CONFIG MODE	B
ENABLE CHANNEL PAIR, FYA	
CH 1-13	OFF
CH 3-14	OFF
CH 5-15	OFF
CH 7-16	OFF
RED/YEL INPUT ENABLE	
CH 1	OFF
CH 3	OFF
CH 5	OFF
CH 7	OFF
FLASH RATE FAULT	ON
FYA TRAP DETECT	ON

MMU PROGRAMMING NOTE
 ENSURE YELLOW CHANGE PLUS RED CLEARANCE MONITORING IS ENABLED FOR ALL CHANNELS.

DETECTOR RACK SETUP

INSERT DETECTOR CARDS IN RACK ACCORDING TO THE DETAIL SHOWN BELOW. PARTICULAR DETECTOR CHANNELS WILL CALL PHASES INDICATED.

DET BIU #1	CH3	CH1	CH3	CH1													DET BIU #2
	L3	L1	L7	L5													
	∅ 2	∅ 1	NOT USED	∅ 2	S	S	S	S	S	S	S	S	S	S	S	S	
	21	11		23	L	L	L	L	L	L	L	L	L	L	L	L	
					E	E	E	E	E	E	E	E	E	E	E	E	
					M	M	M	M	M	M	M	M	M	M	M	M	
					P	P	P	P	P	P	P	P	P	P	P	P	
					T	T	T	T	T	T	T	T	T	T	T	T	
					Y	Y	Y	Y	Y	Y	Y	Y	Y	Y	Y	Y	
					2	2	2	2	2	2	2	2	2	2	2	2	
					4	4	4	4	4	4	4	4	4	4	4	4	
					8	8	8	8	8	8	8	8	8	8	8	8	
					12	12	12	12	12	12	12	12	12	12	12	12	

APS PUSH BUTTON INPUT SETUP

W-5710AK	JOB NO.	DJW	PREPARED BY	03-2022	DATE
01907	SIGNAL NO.	10-2400	NC DOT ID NO.	L. MOON	APPROVER

NC 16 (BROOKSHIRE BLVD) SB @ PLEASANT GROVE RD U-TURN

SIGNAL DETAILS

SHEET SIG6.2 OF SIG6.6

Plans Prepared For: CITY OF CHARLOTTE DEPARTMENT OF TRANSPORTATION 600 E. 4TH ST. ST. LOUIS, MO. NC 28202 704.252-4119 FAX: 704.336-4660

Plans Prepared By: DRMP, Inc. 8000 Regency Parkway, Suite 110 Charlotte, NC 28226 (919) 859-1038 NC License No. C-2216

REVISION DESCRIPTION

NO. DATE BY

Seal: NORTH CAROLINA PROFESSIONAL SEAL 022516 ENGINEER LISA M. MOON

Disseminated by: Lisa M. Moon 3/25/2022

DOCUMENT NOT CONSIDERED FINAL UNLESS ALL SIGNATURES COMPLETED

LEGEND
 ○ EXISTING SPLICE
 ● NEW SPLICE
 ALL UNUSED FIBERS ARE TO BE EXPRESSED THROUGH.

SPLICE 01907

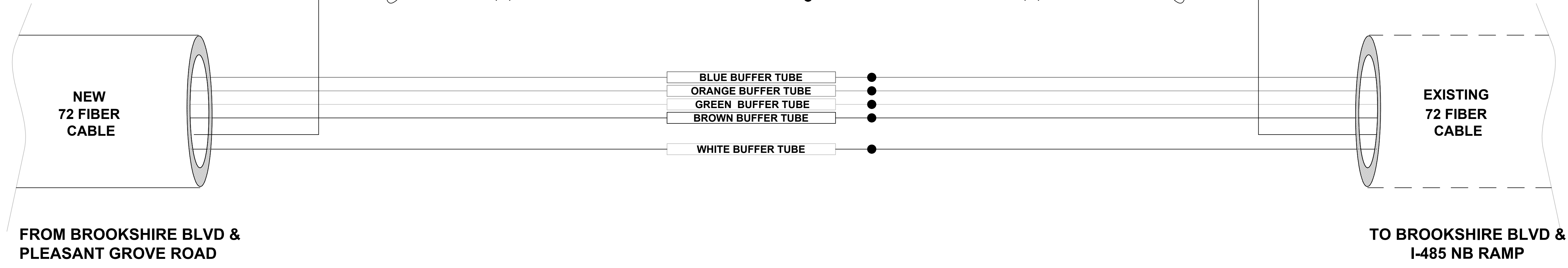
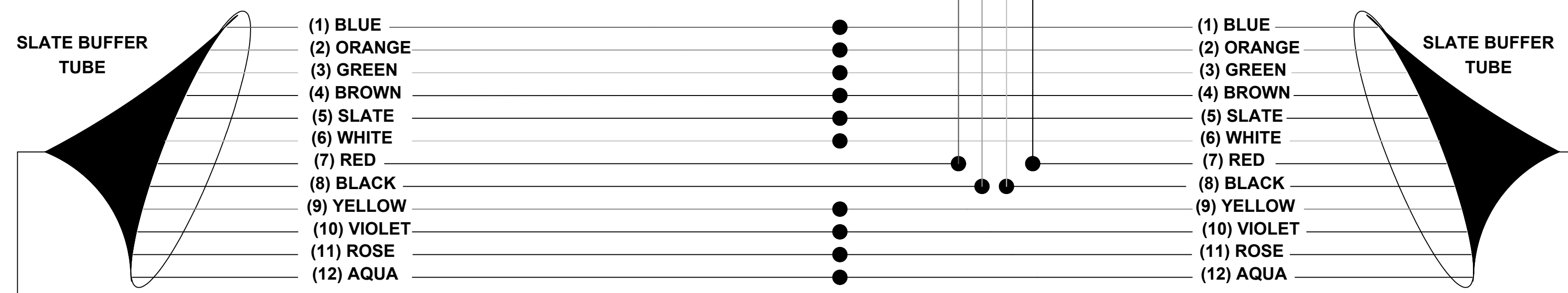
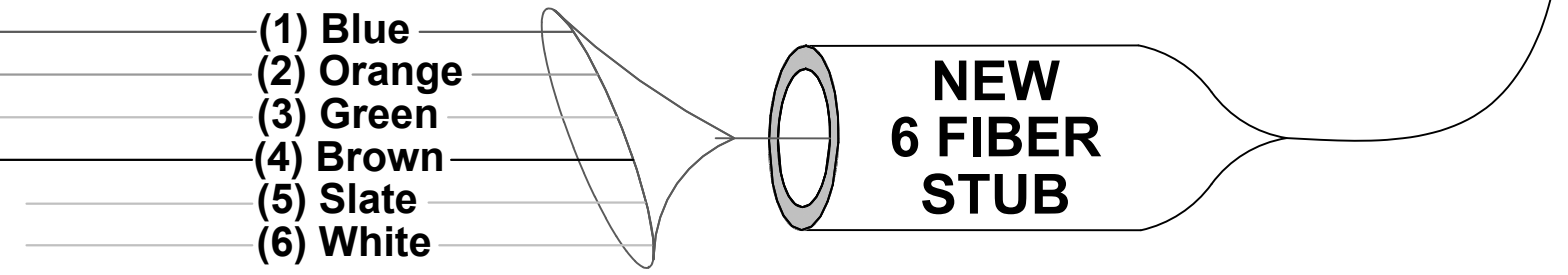
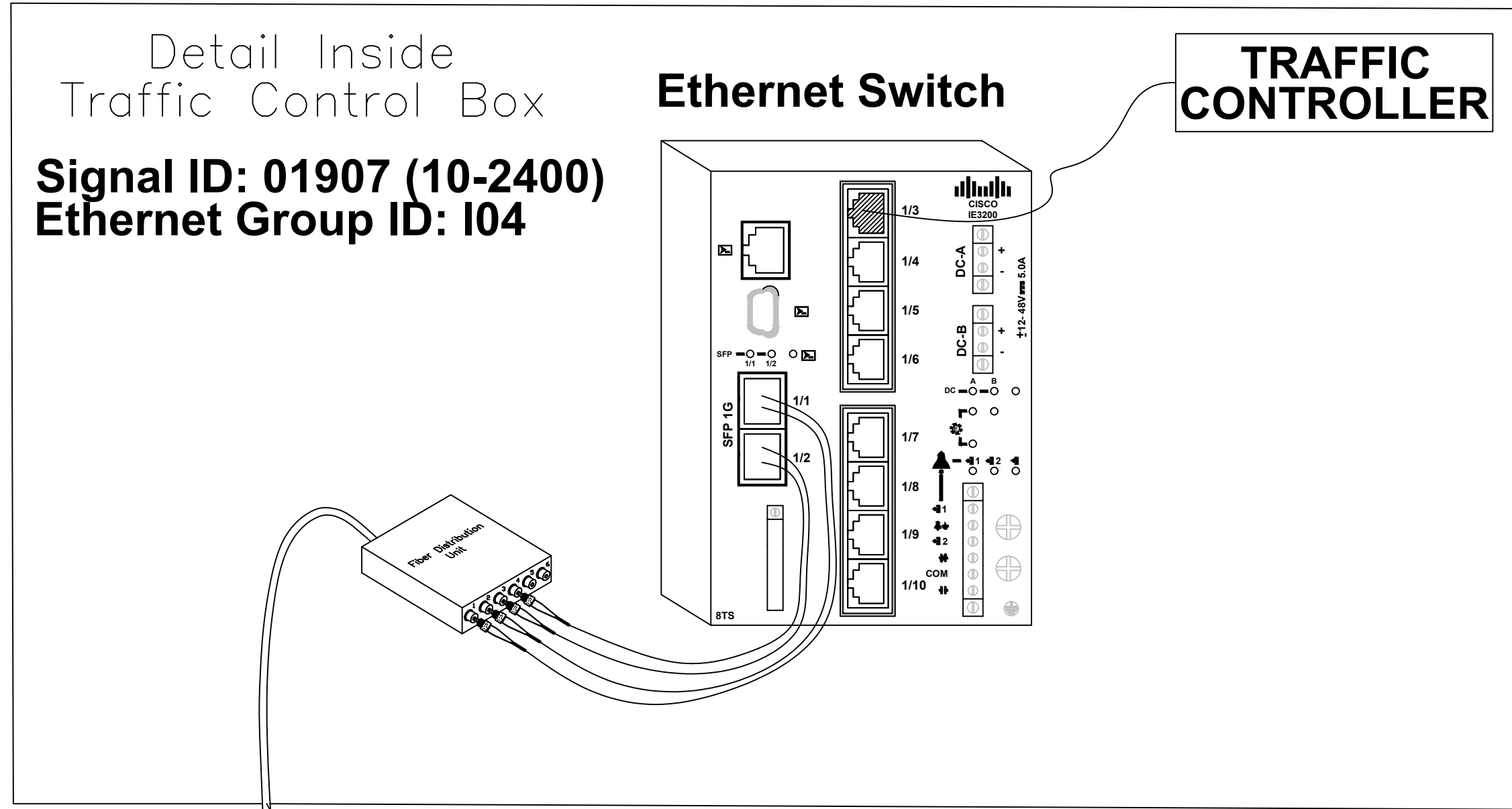

SPLICE CASE IN HANDHOLE# 16.4 ON SB BROOKSHIRE BLVD AT PLEASANT GROVE RD U-TURN



Plans Prepared For:
CITY OF CHARLOTTE
 DEPARTMENT OF
 TRANSPORTATION
 600 E. 4TH ST. 1ST FLOOR, NC 28202
 704.259.4191 FAX: 704.336.4660

Plans Prepared By:
DRMP
 DRMP, Inc.
 8000 Regency Parkway, Suite 110
 Cary, NC 27513
 NC License No. C-2216 (919) 659-1038

NO.	DATE	BY	REVISION DESCRIPTION

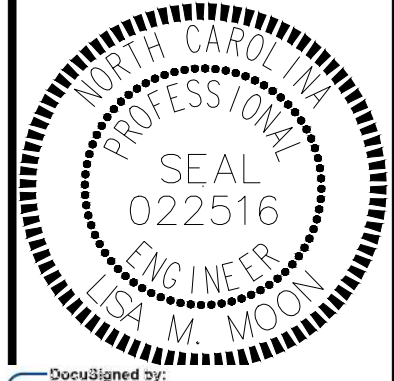

Designed by: *Lisa M. Moon* /25/2022
 SEALS/STAMPS/LOGS
 DOCUMENT NOT CONSIDERED FINAL UNLESS ALL SIGNATURES COMPLETED

01907 SIGNAL NO.	10-2400 NCDOT ID NO.	L. MOON APPROVER	W-5710AK JOB NO.	DJW PREPARED BY	03-2022 DATE
---------------------	-------------------------	---------------------	---------------------	--------------------	-----------------

NC 16 (BROOKSHIRE BLVD) SB @ PLEASANT GROVE RD U-TURN
FIBER OPTIC SPLICE DETAILS

SIGNAL HEAD WIRING

		SIGNAL HEAD HOOK UP CHART															
CHANNEL		1	2	3	4	5	6	7	8	9	10	11	12	13	14	15	16
PHASE		1	2	3	4	5	6	7	8	2 PED	4 PED	6 PED	8 PED	OL-A	OL-B	OL-C	OL-D
SIGNAL HEAD NO.		11	12	22	21	NU	NU	NU	NU	NU	NU	NU	NU	NU	NU	NU	NU
RED	Wire			22R	21R												
	Terminal			LS2-R	[22R]												
YELLOW	Wire			22Y	21Y												
	Terminal			LS2-Y	[22Y]												
GREEN	Wire			22G	21G												
	Terminal			LS2-G	[22G]												
RED ARROW	Wire	11RS	12RS														
	Terminal	LS1-R	LS1-R														
YELLOW ARROW	Wire	11YS	12YS														
	Terminal	LS1-Y	LS1-Y														
FLASHING YELLOW	Wire																
	Terminal																
GREEN ARROW	Wire	11GS	12GS														
	Terminal	LS1-G	LS1-G														

[XX*] = TERMINAL BLOCK IN SIGNAL HEAD | LSX* = TERMINAL IN LOAD BAY | NU = NOT USED

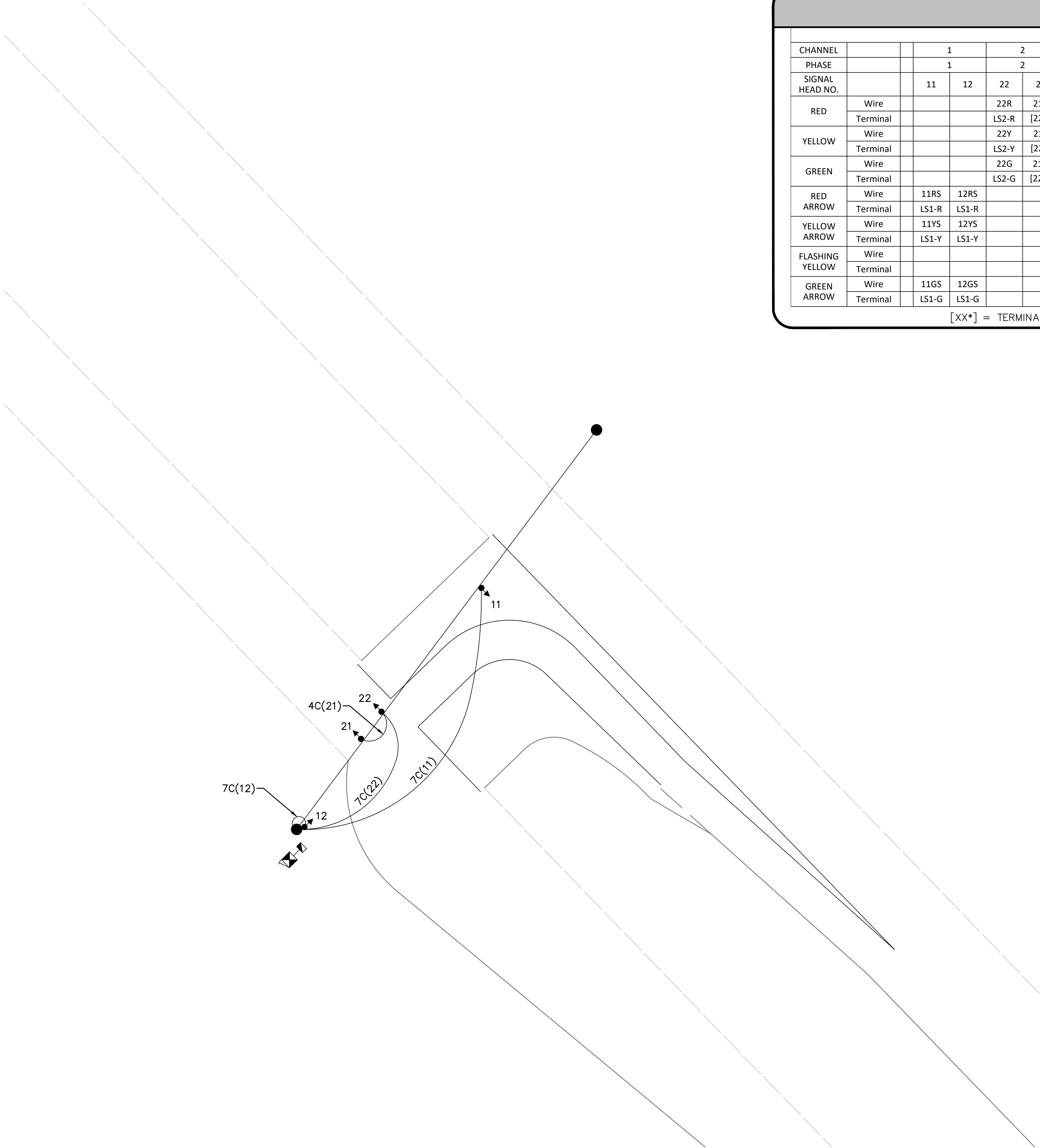

SIGNAL WIRE NAMING CONVENTION:
CABLES:
 xC(nn) x = #of conductors in cable, nn = cable number

WIRES:
 nnA nn = cable number, A = conductor in cable

EXAMPLE: 7C(41)

NOTE: Conductor colors may vary. Record plan actual colors installed.



Plans Prepared For:
CITY OF CHARLOTTE
 DEPARTMENT OF
 TRANSPORTATION
 600 E. 4TH STREET, 3RD FLOOR, NC 28202
 704.656.4191 FAX 704.356.4460

Plans Prepared By:
DRMP
 DRMP, Inc.
 8000 Regency Parkway, Suite 110
 Charlotte, NC 28226
 NC License No. C-2216 (919) 869-0088

NO.	DATE	BY	REVISION DESCRIPTION



Designed by: *Lisa M. Moon* /25/2022
 DOCUMENT NOT CONSIDERED FINAL UNLESS ALL SIGNATURES COMPLETED

01907	W-5710AK	03-2022
SIGNAL NO.	JOB NO.	DATE
10-2400	DJM	
NC DOT ID NO.	PREPARED BY	
L. MOON		
APPROVER		

NC 16 (BROOKSHIRE BLVD) SB
 @ PLEASANT GROVE RD U-TURN

SIGNAL WIRING DIAGRAM

SHEET
SIG6.4
 OF
SIG6.6

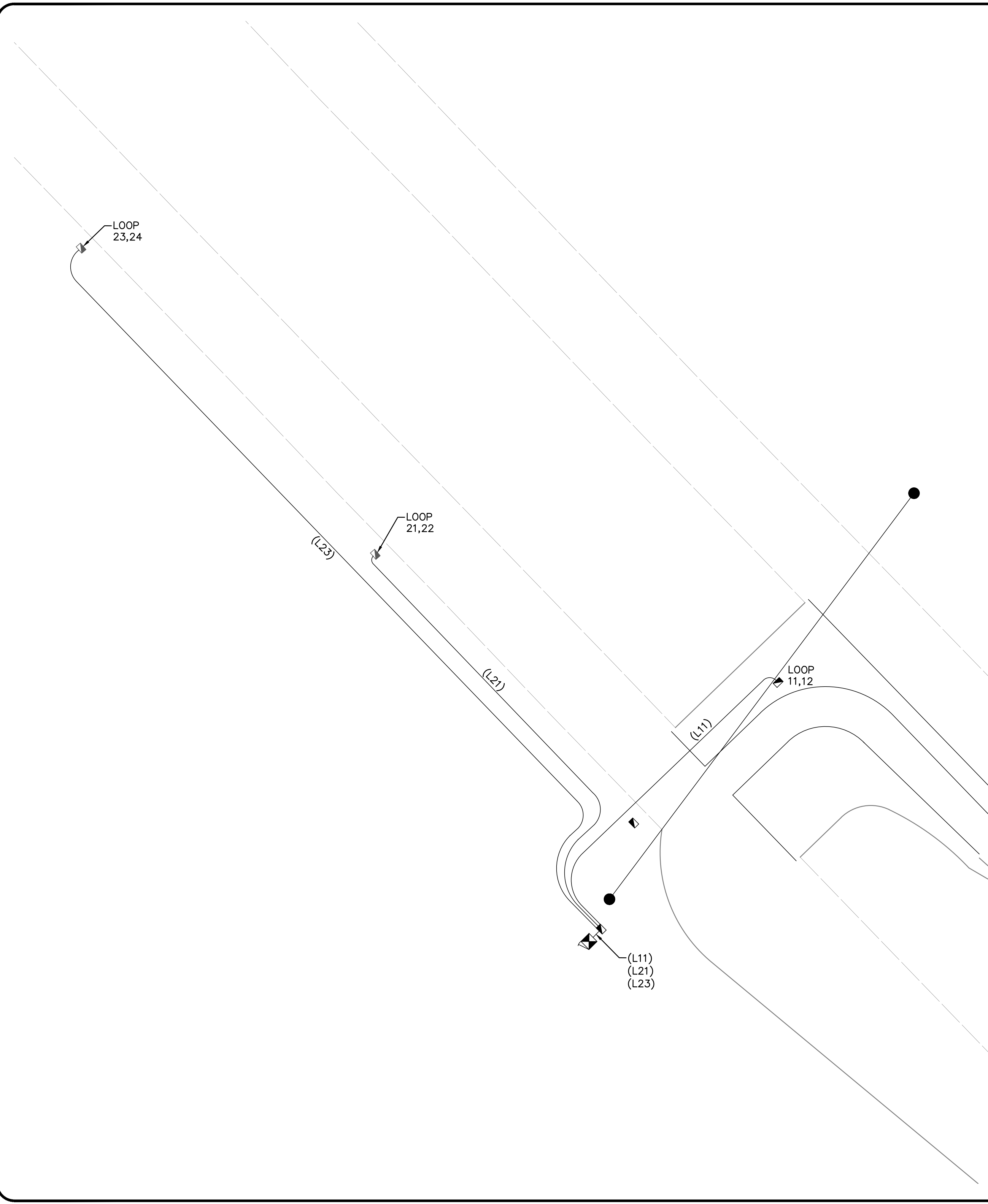

LOOP WIRING

Loop Number	Wire	Terminal	Controller Detector Number	Phase	Timing		Size	Comments
					Feature	Time (sec)		
11	L11-1-W	LT1-1	1	1	-	-	6'X25'	@ STOP BAR
	L11-1-B	LT1-2						
12	L11-2-R	LT1-3	2	1	-	-	6'X25'	65' FROM STOP BAR
	L11-2-B	LT1-4						
21	L21-1-W	LT1-5	3	2	-	-	6'X6'	130' FROM STOP BAR
	L21-1-B	LT1-6						
22	L21-2-R	LT1-7	4	2	-	-	6'X6'	130' FROM STOP BAR
	L21-2-B	LT1-8						
23	L23-1-W	LT1-9	5	2	-	-	6'X6'	280' FROM STOP BAR
	L23-1-B	LT1-10						
24	L23-2-R	LT1-11	6	2	-	-	6'X6'	280' FROM STOP BAR
	L23-2-B	LT1-12						

NOTE:
All stopbar loops are 5' beyond the stopbar unless otherwise noted.
All loops have 3 turns.

LOW-VOLTAGE WIRE NAMING CONVENTION:

CABLES:
(Ann) A = Loops(L)/Pushbutton(B) nn = cable number

WIRES:
Ann-C-D A = Loops(L)/Pushbutton(B), nn = cable number,
C = pair number, D = conductor in pair

EXAMPLE: (L41)

NOTE: Conductor colors may vary. Record plan actual colors installed.

NOTE

CDOT TO PROGRAM DETECTOR
TYPES AND TIMERS (EXTEND AND
DELAY) AS SHOWN IN LOOP WIRING
CHART ABOVE INTO CONTROLLER



Plans Prepared For:
CITY OF CHARLOTTE
DEPARTMENT OF
TRANSPORTATION
600 E. 4TH STREET, FLOOR 1000, NC 28202
704.255.4119 FAX: 704.336.4660

Plans Prepared By:
DRMP
DRMP, Inc.
8000 Regency Parkway, Suite 110
Charlotte, NC 28226 (919) 659-1038
NC License No. C-2216 (919) 659-4660

NO.	DATE	BY	REVISION DESCRIPTION

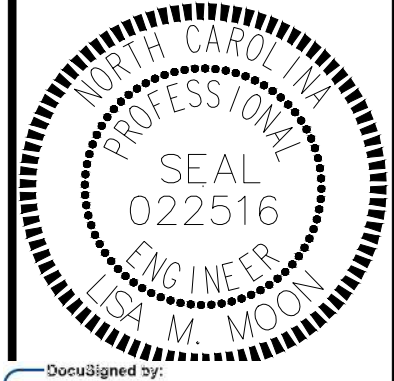

Designed by:
Lisa M. Moon /25/2022
SICFESB03100421

W-5710AK JOB NO.	DJW PREPARED BY	03-2022 DATE
01907 SIGNAL NO.	10-2400 NCDOT ID NO.	L. MOON APPROVER

NC 16 (BROOKSHIRE BLVD) SB
@ PLEASANT GROVE RD U-TURN

**LOW VOLTAGE
WIRING DIAGRAM**

SHEET
SIG6.5

OF
SIG6.6

NOTE:
ALL LEAD-IN WIRE SHOULD BE TWO PAIR CABLE

NOTES

1. To prevent "flash-conflict" problems, wire all unused load switches to flash red. Verify that signal heads flash in accordance with the signal plans.
2. To prevent red failures on unused monitor channels, tie unused load switch red outputs 3, 4, 5, 6, 7, 8, 9, 10, 11, 12, 13, 14, 15 and 16 to load switch AC+ by inserting a jumper plug in the unused load switch socket from pin 1 (LS AC+) to pin 3 (RED out). Make sure all flash transfer relays are in place.
- ◆ 3. Program controller to start up in phase 2 Green.
- ◆ 4. Set power-up flash time to 12 seconds and implement on the Malfunction Management Unit. Set controller power-up flash time to 22 seconds.
- ◆ 5. Program detectors in accordance with the manufacturer's instructions to accomplish the detection schemes shown on the signal design plans.
- ◆ 6. Program detector call delay and extension timing on the controller, unless otherwise specified.
7. Set all detector card unit channels to "presence" mode.
8. The cabinet and controller are a part of the Charlotte Signal System.

◆ Software and Programming by CDOT

City of Charlotte Department of Transportation (CDOT) to provide EOS Software and do all Programming of the controller database. Contractor to provide CDOT with controller for programming a minimum of two weeks prior to installation. CDOT will return controller, fully programmed for contractor to install and integrate into the controller cabinet.

EQUIPMENT INFORMATION

CONTROLLER.....2070LX
 CABINETTS-2
 SOFTWAREECONOLITE EOS-2070
 CABINET MOUNT.....BASE
 LOADBAY POSITIONS.....16
 LOAD SWITCHES USED.....1,2
 PHASES USED.....1,2
 OLA.....NOT USED
 OLB.....NOT USED
 OLC.....NOT USED
 OLD.....NOT USED



Plans Prepared For:
CITY OF CHARLOTTE
 DEPARTMENT OF
 TRANSPORTATION
 600 E. 4TH ST. CHARLOTTE, NC 28202
 704.359.4191 FAX: 704.359.4660

Plans Prepared By:

DRMP, Inc.
 8000 Regency Parkway, Suite 110
 Cary, NC 27513
 NC License No. C-2216 (919) 659-1038

NO.	DATE	BY	REVISION DESCRIPTION



Designed by: Lisa M. Moon 25/2022

DOCUMENT NOT CONSIDERED FINAL UNLESS ALL SIGNATURES COMPLETED

W-5710AK JOB NO.	D.J.W PREPARED BY	03-2022 DATE
01907 SIGNAL NO.	10-2400 NCDOT ID NO.	L. MOON APPROVER

**NC 16 (BROOKSHIRE BLVD) SB
 @ PLEASANT GROVE RD U-TURN**
**MISCELLANEOUS
 DETAILS**

SHEET
SIG6.6
 OF
SIG6.6

- 1 INSTALL SIGNAL CABLE
- 2 INSTALL ETHERNET CABLE
- 3 EXISTING ETHERNET (OR COAX) CABLE
- 4 INSTALL SMFO CABLE
- 5 EXISTING SMFO CABLE
- 6 INSTALL FIBER OPTIC DROP CABLE
- 7 INSTALL TRACER WIRE
- 8 TRENCH
- 9 INSTALL PVC CONDUIT
- 10 INSTALL RIGID, GALVANIZED STEEL CONDUIT
- 11 INSTALL RIGID, GALVANIZED STEEL RISER WITH WEATHERHEAD
- 12 INSTALL RIGID, GALVANIZED STEEL RISER WITH FIBER OPTIC CABLE SEAL
- 13 INSTALL OUTER-DUCT POLYETHYLENE CONDUIT
- 14 INSTALL POLYETHYLENE CONDUIT
- 15 DIRECTIONAL DRILL CONDUIT
- 16 BORE AND JACK CONDUIT
- 17 INSTALL CABLE(S) IN EXISTING CONDUIT
- 18 INSTALL CABLE(S) IN NEW CONDUIT
- 19 INSTALL CABLE(S) IN EXISTING RISER
- 20 INSTALL CABLE(S) IN NEW RISER
- 21 INSTALL CABLE(S) IN EXISTING CONDUIT STUB-OUTS
- 22 INSTALL NEW CONDUIT INTO EXISTING CABINET BASE (USE EXISTING CONDUIT STUB-OUTS WHEN AVAILABLE)
- 23 INSTALL NEW RISER INTO EXISTING CABINET BASE (USE EXISTING CONDUIT STUB-OUTS WHEN AVAILABLE)
- 24 INSTALL NEW CONDUIT INTO EXISTING POLE MOUNTED CABINET
- 25 INSTALL NEW RISER INTO EXISTING POLE MOUNTED CABINET
- 26 INSTALL NEW ETHERNET EDGE SWITCH
- 27 INSTALL NEW FIBER OPTIC TRANSCEIVER
- 28 INSTALL INTERCONNECT CENTER, PATCH PANEL, JUMPERS AND FUSION SPLICE CABLE IN CABINET
- 29 INSTALL UNDERGROUND SPLICE ENCLOSURE
- 30 INSTALL AERIAL SPLICE ENCLOSURE
- 31 MODIFY EXISTING INTERCONNECT CENTER /SPLICE ENCLOSURE
- 32 INSTALL POLE MOUNTED SPLICE CABINET
- 33 INSTALL BASE MOUNTED SPLICE CABINET

- 34 INSTALL CABINET FOUNDATION
- 35 INSTALL CCTV CAMERA POLE MOUNTED CABINET
- 36 INSTALL CCTV CAMERA ASSEMBLY
- 37 INSTALL CCTV CAMERA WOOD POLE
- 38 INSTALL TYPE III PEDESTAL POLE AND FOUNDATION FOR CCTV
- 39 INSTALL CDOT TYPE 1 JUNCTION BOX
- 40A INSTALL CDOT TYPE 2 JUNCTION BOX
- 40B INSTALL CDOT UH-2 SPECIAL OVERSIZED JUNCTION BOX (36" x 24" x 30")
- 41 REMOVE EXISTING JUNCTION BOX
- 42 INSTALL WOOD POLE
- 43 REMOVE EXISTING WOOD POLE
- 44 INSTALL AERIAL GUY ASSEMBLY
- 45 INSTALL STANDARD GUY ASSEMBLY
- 46 INSTALL SIDEWALK GUY ASSEMBLY
- 47 INSTALL MESSENGER CABLE
- 48A REMOVE EXISTING COMMUNICATIONS AND MESSENGER CABLE
- 48B REMOVE EXISTING COMMUNICATIONS CABLE
- 49 BACK PULL EXISTING COMMUNICATIONS CABLE
- 50 INSTALL CELL MODEM AND ANTENNA
- 51 INSTALL CABLE STORAGE RACKS (SNOW SHOES) AND STORE 100 FEET OF CABLE
- 52A INSTALL DELINEATOR MARKER
- 52B INSTALL JUNCTION BOX MARKER
- 53A STORE 20 FEET OF COMMUNICATIONS CABLE
- 53B STORE 50 FEET OF EACH COMMUNICATIONS CABLE
- 54 LASH CABLE(S) TO EXISTING COMMUNICATIONS CABLE
- 55 LASH CABLE(S) TO EXISTING MESSENGER CABLE
- 56 LASH CABLE(S) TO NEW MESSENGER CABLE
- 57 MODIFY EXISTING ELECTRICAL SERVICE
- 58 INSTALL NEW ELECTRICAL SERVICE
- 59 INSTALL NEW EQUIPMENT CABINET DISCONNECT
- 60 BOND TRACER WIRE TO EQUIPMENT GROUND BUS
- 61 DO NOT BOND TRACER WIRE TO EQUIPMENT GROUND BUS
- 62 BOND RISER AND MESSENGER CABLE TO POLE GROUND
- 63 BOND RISER TO POLE GROUND
- 64 BOND MESSENGER CABLE TO POLE GROUND
- 65 INSTALL HEAT SHRINK TUBING RETROFIT KIT
- 66 INSTALL MOLDABLE DUCT SEAL
- 67 SLACK SPAN

- 68 INTERCEPT EXISING CONDUIT
- 69 INSTALL ELECTRONIC BALL MARKER
- 70 MODIFY EXISTING CCTV CAMERA ASSEMBLY

LEGEND

	NEW FIBER OPTIC COMMUNICATIONS CABLE
	EXISTING COMMUNICATIONS CABLE
	EXISTING COMMUNICATIONS CABLE TO BE REMOVED
	NEW AERIAL GUY ASSEMBLY
	NEW CONDUIT
	EXISTING CONDUIT
	NEW DIRECTIONAL DRILLED CONDUIT

NEW		EXISTING
	OVERSIZED JUNCTION BOX	
	WOOD POLE	
	AERIAL SPLICE ENCLOSURE	
	UNDERGROUND SPLICE ENCLOSURE	
	METAL POLE	
	CCTV ASSEMBLY	
	STANDARD GUY ASSEMBLY	
	SIDEWALK GUY ASSEMBLY	
	CABLE STORAGE RACKS (SNOW SHOES)	
	SIGNAL/EQUIPMENT CABINET	
	SPLICE CABINET	
	FLAT PANEL ANTENNA (SINGLE)	
	YAGI ANTENNA (DOUBLE) FOR REPEATER OPERATION	
	YAGI ANTENNA (SINGLE)	
	OMNI ANTENNA	
	SIGNAL POLE	
	SIGNAL INVENTORY NUMBER	

CONSTRUCTION NOTE SYMBOLOGY KEY

	INDICATES NUMBER OF CABLES, LOOPS, ETC.
	INDICATES NUMBER OF FIBERS PER CABLE, TWISTED PAIRS PER CABLE, ETC.
	INDICATES NUMBER OF RISER(S)/CONDUIT(S)
	INDICATES DIAMETER OF RISER(S)/CONDUIT(S) (INCH)

	NUMBER OF CABLE(S)
	NUMBER OF FIBERS/TWISTED PAIRS
	NUMBER OF RISER(S)/CONDUIT(S)
	DIAMETER OF RISER(S)/CONDUIT(S) (INCH)

'SS' symbol"/>	DISTANCE ABOVE (IN)/ATTACHMENT POINT REFERENCE POINT
	REFERENCE POINT
'SS' symbol"/>	DISTANCE BELOW (IN)/ATTACHMENT POINT

"SS"	REFERENCE LOCATION
FS =	FRONT SIDE OF POLE
BS =	BACK SIDE OF POLE

City of Charlotte
Department of Transportation
600 East Fourth Street
Charlotte, North Carolina 28202
Phone: (704) 336-4119

Plans Prepared For:

REVISIONS

DOCUMENT NOT CONSIDERED FINAL UNLESS ALL SIGNATURES COMPLETE

<p>Plans Prepared By:</p> <p>DRMP, Inc. 8000 Regency Parkway, Suite 110 Charlotte, NC 28213 (704) 655-1038 NC License No. C-2713</p>	<table border="1" style="width: 100%; border-collapse: collapse;"> <tr> <td style="width: 25%;">NA</td> <td style="width: 25%;">SCALE</td> <td style="width: 25%;">NCDOT SIGNAL ID</td> <td style="width: 25%;">C. Silver</td> </tr> <tr> <td style="width: 25%;">W-57/0AK</td> <td style="width: 25%;">JOB NO.</td> <td style="width: 25%;">Signal ID</td> <td style="width: 25%;">D. White</td> </tr> <tr> <td style="width: 25%;">SHEET</td> <td style="width: 25%;">SCP 1</td> <td style="width: 25%;">PREPARED BY</td> <td style="width: 25%;">L. Moon</td> </tr> <tr> <td style="width: 25%;">OF</td> <td style="width: 25%;">OF</td> <td style="width: 25%;">CHECKED BY</td> <td style="width: 25%;">AUGUST 2022</td> </tr> <tr> <td style="width: 25%;">DATE</td> <td style="width: 25%;">DATE</td> <td style="width: 25%;">APPROVED BY</td> <td style="width: 25%;">DATE</td> </tr> </table>	NA	SCALE	NCDOT SIGNAL ID	C. Silver	W-57/0AK	JOB NO.	Signal ID	D. White	SHEET	SCP 1	PREPARED BY	L. Moon	OF	OF	CHECKED BY	AUGUST 2022	DATE	DATE	APPROVED BY	DATE
NA	SCALE	NCDOT SIGNAL ID	C. Silver																		
W-57/0AK	JOB NO.	Signal ID	D. White																		
SHEET	SCP 1	PREPARED BY	L. Moon																		
OF	OF	CHECKED BY	AUGUST 2022																		
DATE	DATE	APPROVED BY	DATE																		

SIGNAL COMMUNICATION PLAN CONSTRUCTION NOTES

SHEET SCP 1 OF 17



City of Charlotte
Department of Transportation
600 East Fourth Street
Charlotte, North Carolina 28202
Phone: (704) 336-4119



REVISIONS

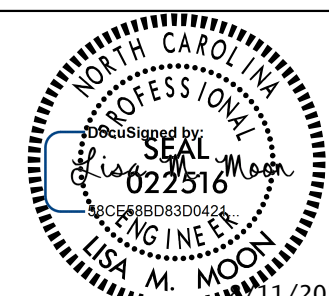

DOCUMENT NOT CONSIDERED FINAL
UNLESS ALL SIGNATURES COMPLETED

Plans Prepared By:

DRMP, Inc.
8000 Regency Parkway, Suite 110
Charlotte, NC 28226
NC License No. C-2213 (819) 855-0338

W-5710AK	1" = 50'
JOB NO.	SCALE
00838, 01904	10-0659, 10-2403
Signal ID	NC DOT SIGNAL ID
D. White	C. Silver
PREPARED BY	CHECKED BY
L. Moon	AUGUST 2022
APPROVED BY	DATE

SIGNAL COMMUNICATION PLAN LAYOUT

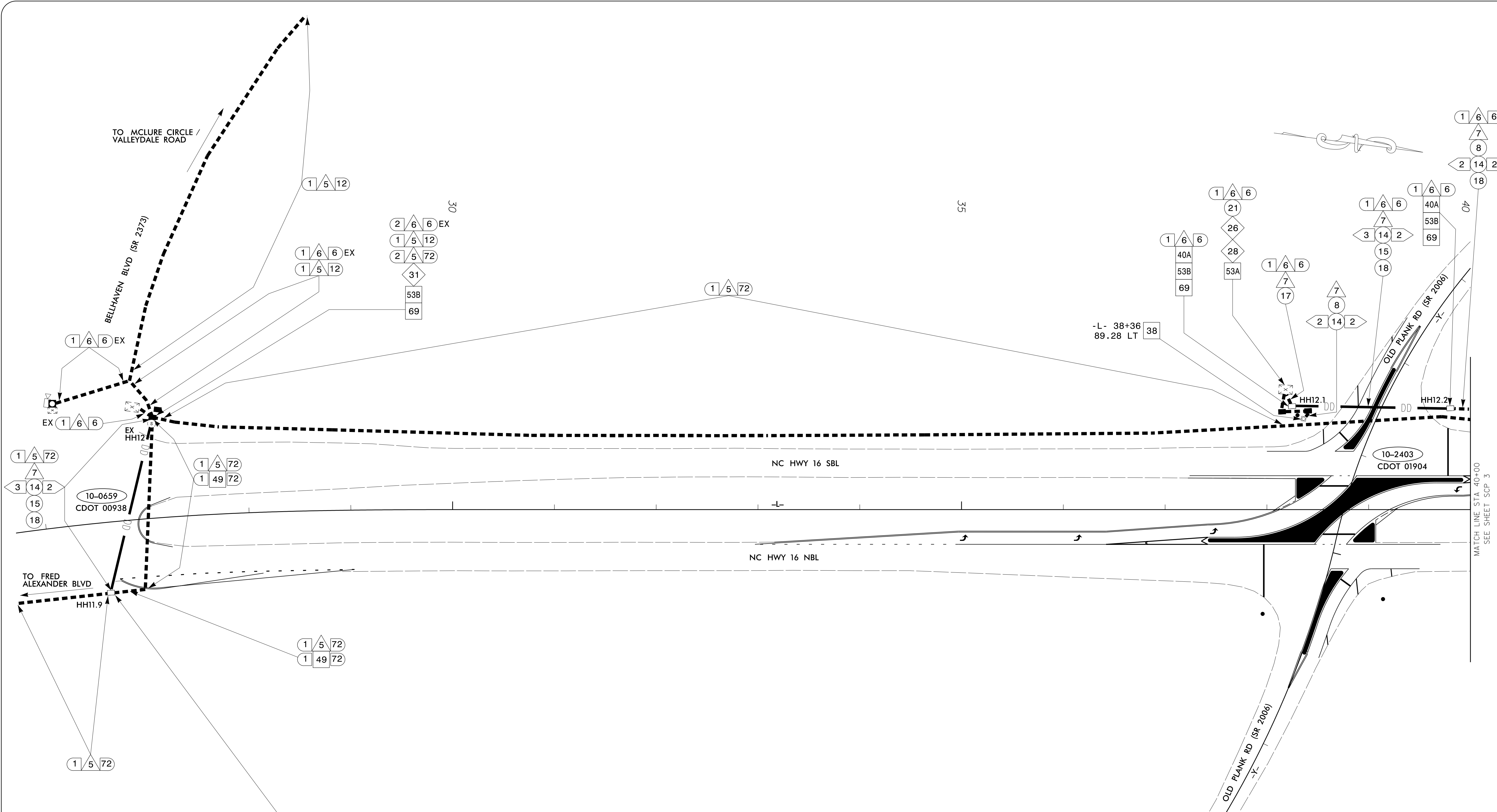

CONSTRUCTION NOTES:

1. ALL EFFORTS SHALL BE MADE TO LIMIT THE AMOUNT OF DOWN TIME TO THE SYSTEM. PRIOR TO DISCONNECTION OF THE EXISTING FO CABLE, DOCUMENT AND TAKE PHOTOS OF EXISTING SPLICE.
2. CONTRACTOR TO RECORD EXISTING SPLICE ARRANGEMENT FOR COMPARISON TO THE SUPPLIED SPLICE DETAILS. IF DISCREPANCIES EXIST, CONTACT THE ENGINEER TO DETERMINE HOW TO PROCEED WITH REPLACING. PROVIDE AS-BUILT PLANS TO THE ENGINEER IF FINAL SPLICE ARRANGEMENT DIFFERS FROM THE SUPPLIED SPLICE DETAILS.
3. FIVE (5) DAYS PRIOR TO CUTTING ANY EXISTING FIBER AND FIVE (5) DAYS PRIOR TO BEGINNING WORK ON THE SIGNAL SYSTEM, CONTACT THE CHARLOTTE ENGINEERING PROJECT COORDINATOR, MARK ODEM, AT (980)230-1847 TO COORDINATE DOWN TIME FOR SIGNAL SYSTEM DUE TO THIS PROJECT. NOTIFY ENGINEERING PROJECT COORDINATOR AFTER ALL WORK PERFORMED TO ENSURE THAT ALL FIBER CIRCUITS ARE FUNCTIONING PROPERLY. WORK IS NOT COMPLETE UNTIL THE SIGNAL SYSTEM IS BACK UP AND OPERATIONAL.
4. MAINTAIN AS MUCH EXISTING FIBER OPTIC CABLE AS POSSIBLE. ANY ADDITIONAL SPARE CABLE NOT SPECIFIED IN CONSTRUCTION NOTES SHALL BE STORED IN JUNCTION BOXES NOTED.
5. DISCONNECT AND PULL BACK EXISTING FIBER OPTIC CABLE FROM EXISTING SPLICE LOCATION TO NEW JUNCTION BOX AS SHOWN.
6. REROUTE EXISTING CABLE IN NEW UNDERGROUND CONDUIT SYSTEM AS SHOWN, BACK TO THE EXISTING SPLICE. RE-SPLICE IN EXISTING CONFIGURATION TO MAINTAIN SIGNAL SYSTEM UNTIL ALL FINAL SIGNALS ARE CONSTRUCTED. FOR FINAL CONFIGURATION, SEE SPLICE DETAILS TO CREATE GROUP I04.

- 1 5 72
- 40A
- 53A SEE NOTE 4
- 68
- 69

MATCH LINE STA 40+00
SEE SHEET SCP 3

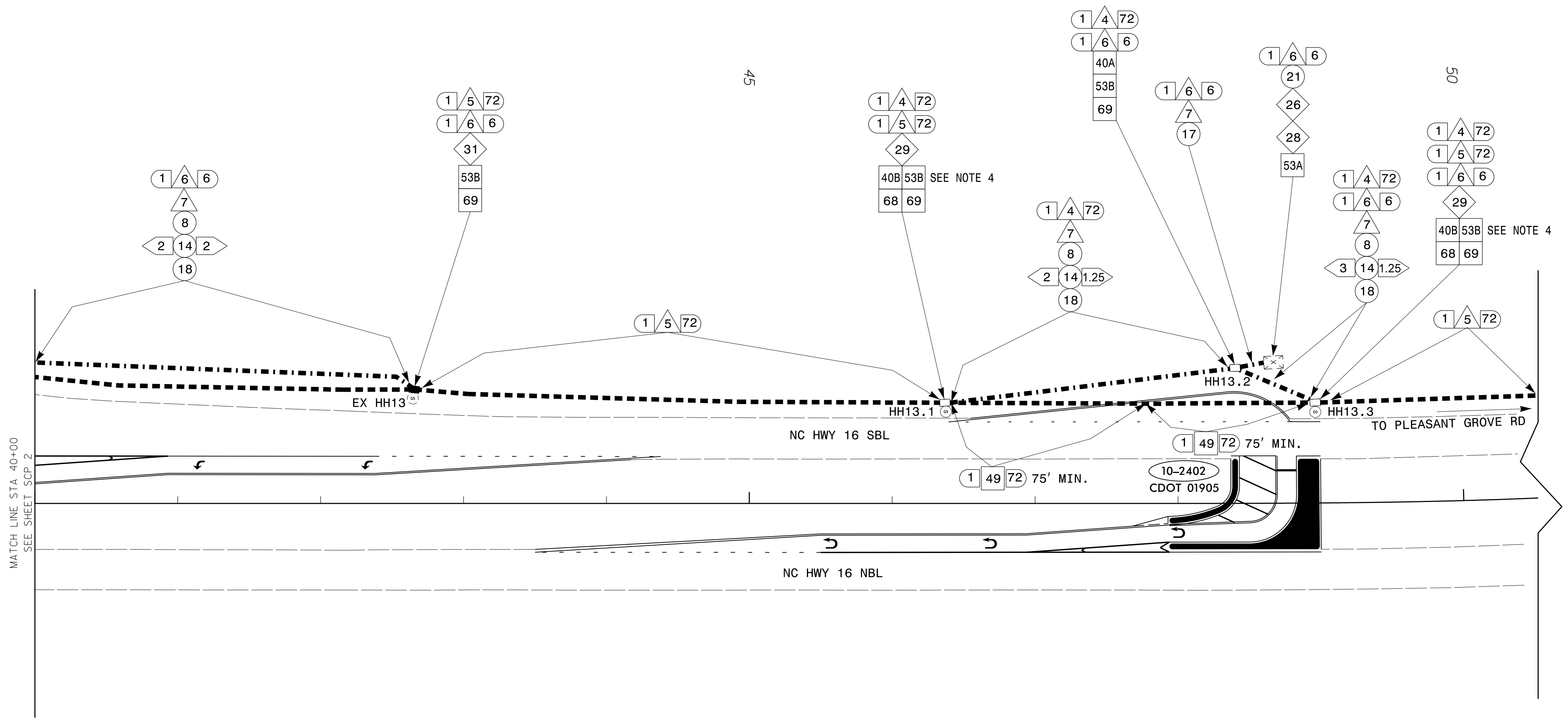
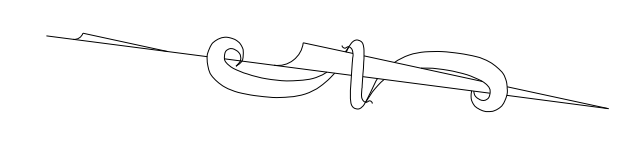

CONSTRUCTION NOTES:

1. ALL EFFORTS SHALL BE MADE TO LIMIT THE AMOUNT OF DOWN TIME TO THE SYSTEM. PRIOR TO DISCONNECTION OF THE EXISTING FO CABLE, DOCUMENT AND TAKE PHOTOS OF EXISTING SPLICE.
2. CONTRACTOR TO RECORD EXISTING SPLICE ARRANGEMENT FOR COMPARISON TO THE SUPPLIED SPLICE DETAILS. IF DISCREPANCIES EXIST, CONTACT THE ENGINEER TO DETERMINE HOW TO PROCEED WITH REPLACING. PROVIDE AS-BUILT PLANS TO THE ENGINEER IF FINAL SPLICE ARRANGEMENT DIFFERS FROM THE SUPPLIED SPLICE DETAILS.
3. FIVE (5) DAYS PRIOR TO CUTTING ANY EXISTING FIBER AND FIVE (5) DAYS PRIOR TO BEGINNING WORK ON THE SIGNAL SYSTEM, CONTACT THE CHARLOTTE ENGINEERING PROJECT COORDINATOR, MARK ODEM, AT (980)230-1847 TO COORDINATE DOWN TIME FOR SIGNAL SYSTEM DUE TO THIS PROJECT. NOTIFY ENGINEERING PROJECT COORDINATOR AFTER ALL WORK PERFORMED TO ENSURE THAT ALL FIBER CIRCUITS ARE FUNCTIONING PROPERLY. WORK IS NOT COMPLETE UNTIL THE SIGNAL SYSTEM IS BACK UP AND OPERATIONAL.
4. MAINTAIN AS MUCH EXISTING FIBER OPTIC CABLE AS POSSIBLE. ANY ADDITIONAL SPARE CABLE NOT SPECIFIED IN CONSTRUCTION NOTES SHALL BE STORED IN JUNCTION BOXES NOTED.
5. PULL BACK EXISTING FIBER OPTIC CABLE TO NEW JUNCTION BOXES AS SHOWN.
6. UTILIZE EXISTING CABLES FOR PROPOSED SPLICES AS SHOWN. BUTT SPLICE COLOR-TO-COLOR TO MAINTAIN SYSTEM DURING SIGNAL CONSTRUCTION. UPDATE SPLICE IN HH13.3 FOR NEW SIGNAL IN PROPOSED GROUP I04 FOR FINAL CONFIGURATION.



Plans Prepared For:
City of Charlotte
 Department of Transportation
 600 East Fourth Street
 Charlotte, North Carolina 28202
 Phone: (704) 336-4119



REVISIONS

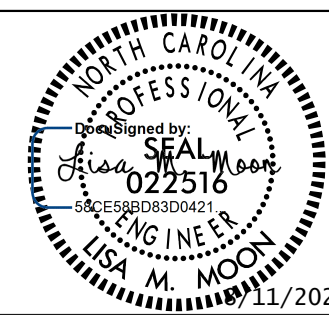

DOCUMENT NOT CONSIDERED FINAL UNLESS ALL SIGNATURES COMPLETED

Plans Prepared By:

DRMP
 DRMP, Inc.
 8000 Regency Parkway, Suite 110
 NC License No. C-2213 (819) 855-1038

W-5710AK	1" = 50'
JOB NO.	SCALE
01905	10-2402
Signal ID	NC DOT SIGNAL ID
D. White	C. Silver
PREPARED BY	CHECKED BY
L. Moon	AUGUST 2022
APPROVED BY	DATE

**SIGNAL
 COMMUNICATION
 PLAN
 LAYOUT**



City of Charlotte
Department of Transportation
600 East Fourth Street
Charlotte, North Carolina 28202
Phone: (704) 336-4119



REVISIONS

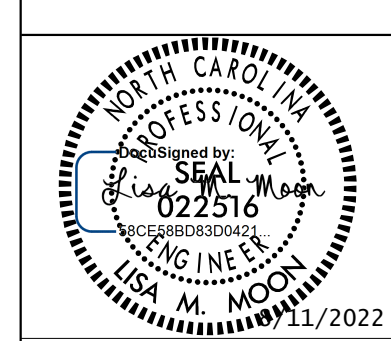

DOCUMENT NOT CONSIDERED FINAL UNLESS ALL SIGNATURES COMPLETED

Plans Prepared By:

DRMP, Inc.
8000 Regency Parkway, Suite 110
NC License No. C-2213 (819) 855-1038

W-5710AK	1" = 50'
JOB NO.	SCALE
1906, 940	10-2401, 10-0880
Signal ID	NC DOT SIGNAL ID
D. White	C. Silver
PREPARED BY	CHECKED BY
L. Moon	AUGUST 2022
APPROVED BY	DATE

SIGNAL COMMUNICATION PLAN LAYOUT

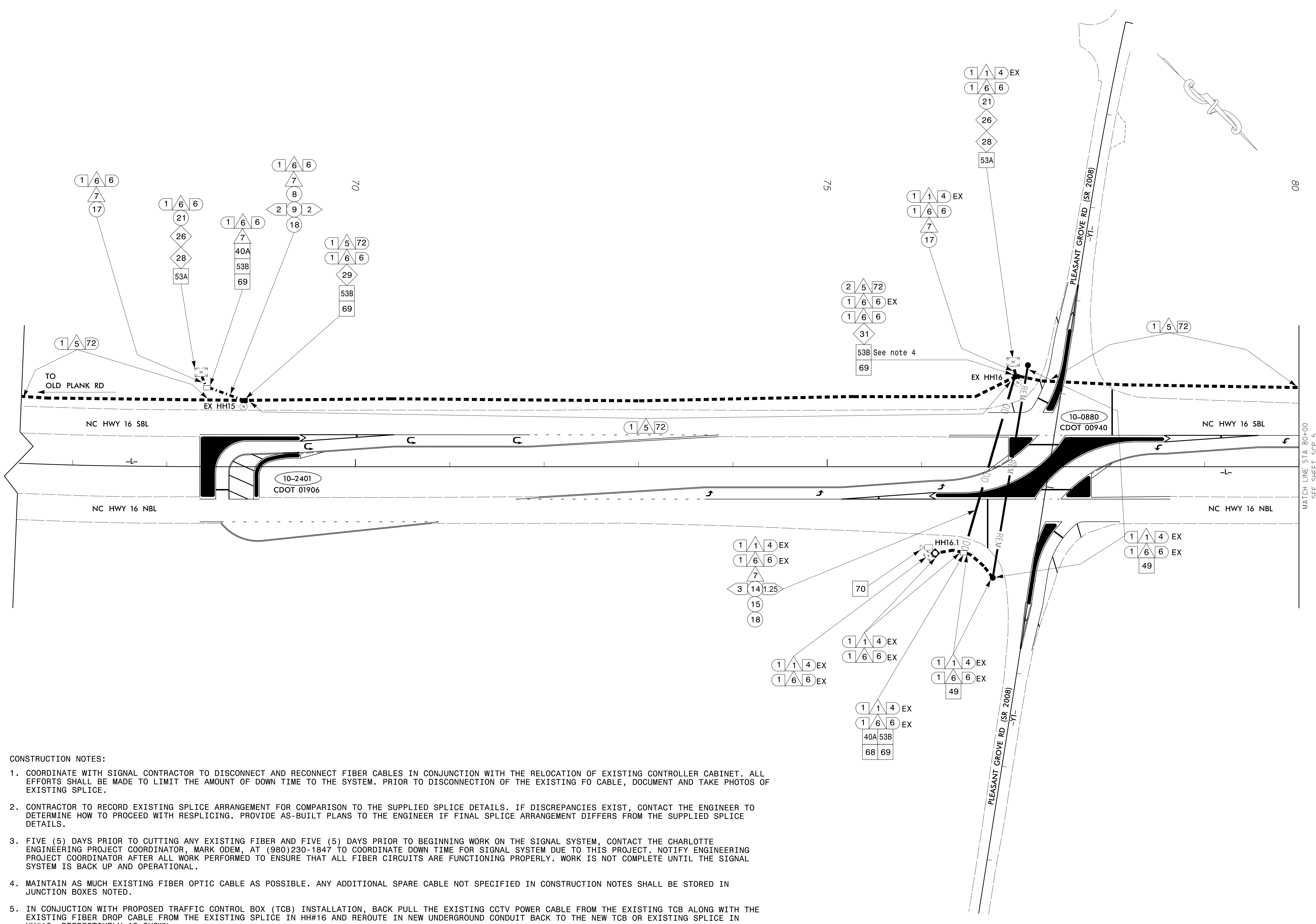

- CONSTRUCTION NOTES:
- COORDINATE WITH SIGNAL CONTRACTOR TO DISCONNECT AND RECONNECT FIBER CABLES IN CONJUNCTION WITH THE RELOCATION OF EXISTING CONTROLLER CABINET. ALL EFFORTS SHALL BE MADE TO LIMIT THE AMOUNT OF DOWN TIME TO THE SYSTEM. PRIOR TO DISCONNECTION OF THE EXISTING FO CABLE, DOCUMENT AND TAKE PHOTOS OF EXISTING SPLICE.
 - CONTRACTOR TO RECORD EXISTING SPLICE ARRANGEMENT FOR COMPARISON TO THE SUPPLIED SPLICE DETAILS. IF DISCREPANCIES EXIST, CONTACT THE ENGINEER TO DETERMINE HOW TO PROCEED WITH RESPLICING. PROVIDE AS-BUILT PLANS TO THE ENGINEER IF FINAL SPLICE ARRANGEMENT DIFFERS FROM THE SUPPLIED SPLICE DETAILS.
 - FIVE (5) DAYS PRIOR TO CUTTING ANY EXISTING FIBER AND FIVE (5) DAYS PRIOR TO BEGINNING WORK ON THE SIGNAL SYSTEM, CONTACT THE CHARLOTTE ENGINEERING PROJECT COORDINATOR, MARK ODEM, AT (980)230-1847 TO COORDINATE DOWN TIME FOR SIGNAL SYSTEM DUE TO THIS PROJECT. NOTIFY ENGINEERING PROJECT COORDINATOR AFTER ALL WORK PERFORMED TO ENSURE THAT ALL FIBER CIRCUITS ARE FUNCTIONING PROPERLY. WORK IS NOT COMPLETE UNTIL THE SIGNAL SYSTEM IS BACK UP AND OPERATIONAL.
 - MAINTAIN AS MUCH EXISTING FIBER OPTIC CABLE AS POSSIBLE. ANY ADDITIONAL SPARE CABLE NOT SPECIFIED IN CONSTRUCTION NOTES SHALL BE STORED IN JUNCTION BOXES NOTED.
 - IN CONJUNCTION WITH PROPOSED TRAFFIC CONTROL BOX (TCB) INSTALLATION, BACK PULL THE EXISTING CCTV POWER CABLE FROM THE EXISTING TCB ALONG WITH THE EXISTING FIBER DROP CABLE FROM THE EXISTING SPLICE IN HH#16 AND REROUTE IN NEW UNDERGROUND CONDUIT BACK TO THE NEW TCB OR EXISTING SPLICE IN HH#16, RESPECTIVELY AS SHOWN.
 - SPLICE NEW DROP CABLE IN EXISTING CONFIGURATION TO MAINTAIN SIGNAL SYSTEM UNTIL ALL FINAL SIGNALS ARE CONSTRUCTED. FOR FINAL CONFIGURATION, SEE SPLICE DETAILS TO CREATE GROUP I04.



City of Charlotte
Department of Transportation
600 East Fourth Street
Charlotte, North Carolina 28202
Phone: (704) 336-4119



REVISIONS

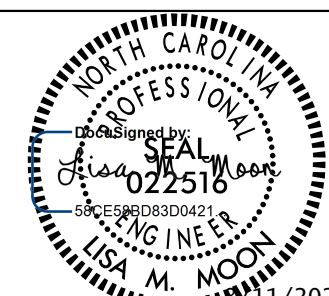

DOCUMENT NOT CONSIDERED FINAL
UNLESS ALL SIGNATURES COMPLETE

Plans Prepared By:



DRMP
DRMP, Inc.
8000 Regency Parkway, Suite 110
Charlotte, NC 28226
NC License No. C-2213 (819) 855-1038

W-57/OAK JOB NO. 1807	1" = 50' SCALE
D. White SIGNAL ID PREPARED BY	10-2400 NCDOT SIGNAL ID
L. Moon APPROVED BY	C. Silver CHECKED BY
	AUGUST 2022 DATE

SIGNAL
COMMUNICATION
PLAN
LAYOUT

SHEET
SCP 5
OF
SCP 17

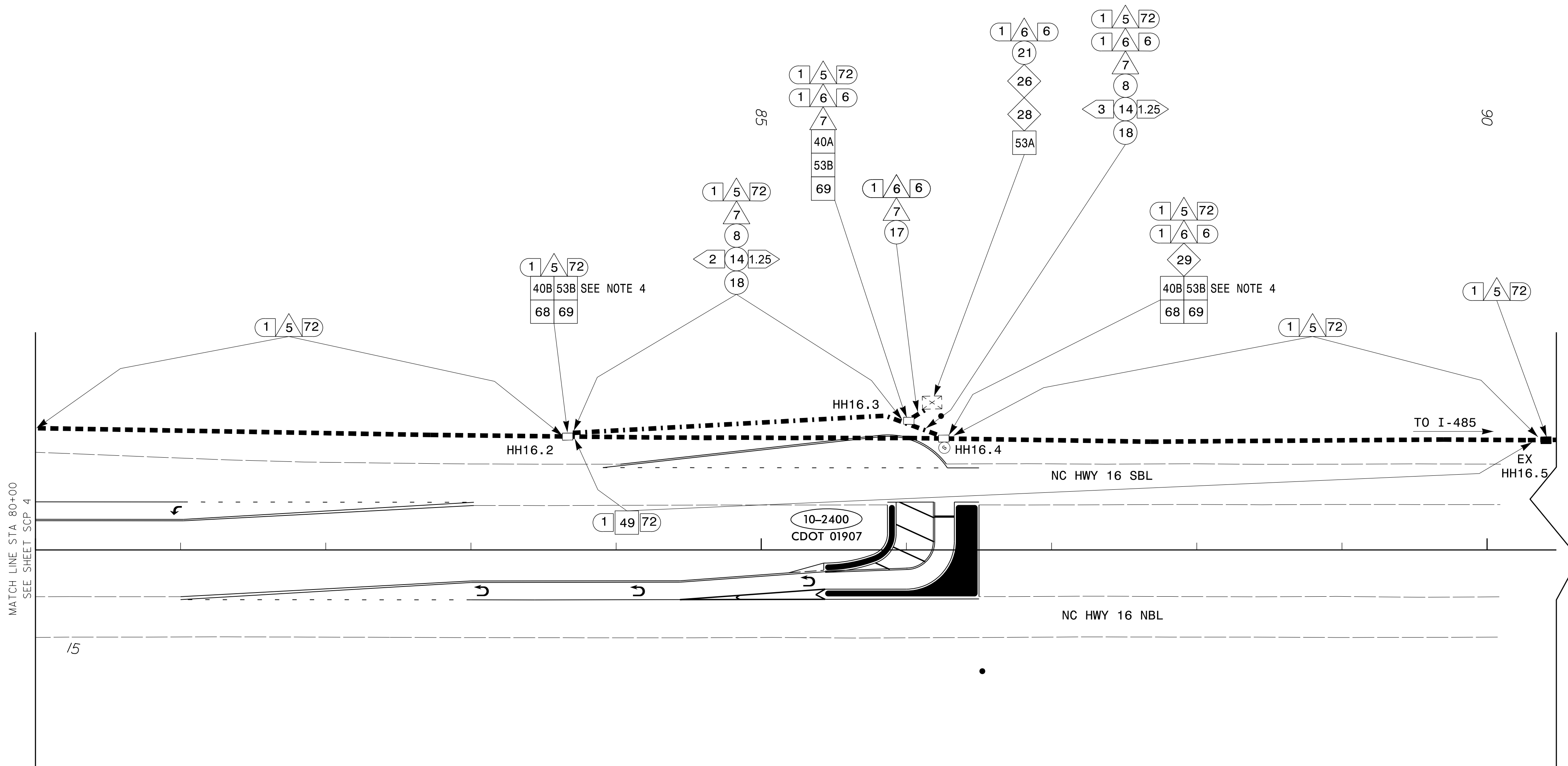

CONSTRUCTION NOTES:

1. ALL EFFORTS SHALL BE MADE TO LIMIT THE AMOUNT OF DOWN TIME TO THE SYSTEM. PRIOR TO DISCONNECTION OF THE EXISTING FO CABLE, DOCUMENT AND TAKE PHOTOS OF EXISTING SPLICE.
2. CONTRACTOR TO RECORD EXISTING SPLICE ARRANGEMENT FOR COMPARISON TO THE SUPPLIED SPLICE DETAILS. IF DISCREPANCIES EXIST, CONTACT THE ENGINEER TO DETERMINE HOW TO PROCEED WITH REPLICING. PROVIDE AS-BUILT PLANS TO THE ENGINEER IF FINAL SPLICE ARRANGEMENT DIFFERS FROM THE SUPPLIED SPLICE DETAILS.
3. FIVE (5) DAYS PRIOR TO CUTTING ANY EXISTING FIBER AND FIVE (5) DAYS PRIOR TO BEGINNING WORK ON THE SIGNAL SYSTEM, CONTACT THE CHARLOTTE ENGINEERING PROJECT COORDINATOR, MARK ODEM, AT (980)230-1847 TO COORDINATE DOWN TIME FOR SIGNAL SYSTEM DUE TO THIS PROJECT. NOTIFY ENGINEERING PROJECT COORDINATOR AFTER ALL WORK PERFORMED TO ENSURE THAT ALL FIBER CIRCUITS ARE FUNCTIONING PROPERLY. WORK IS NOT COMPLETE UNTIL THE SIGNAL SYSTEM IS BACK UP AND OPERATIONAL.
4. MAINTAIN AS MUCH EXISTING FIBER OPTIC CABLE AS POSSIBLE. ANY ADDITIONAL SPARE CABLE NOT SPECIFIED IN CONSTRUCTION NOTES SHALL BE STORED IN JUNCTION BOXES NOTED.
5. DISCONNECT BUTT SPLICE AT EX HH16.5 AND PULL BACK EXISTING FIBER OPTIC CABLE TO NEW HH 16.2 AS SHOWN.
6. UTILIZE EXISTING CABLES FOR PROPOSED SPLICES AS SHOWN.
7. PULL ADDITIONAL SPARE CABLE FROM EX HH 16 AS NECESSARY TO BE ABLE TO SPLICE AT HH16.4 AND TO HAVE SPARE CABLE IN HH16.2 AND HH16.3.
8. INSTALL SPLICE IN HH16.4 FOR NEW SIGNAL IN PROPOSED GROUP IO4 FOR FINAL CONFIGURATION.

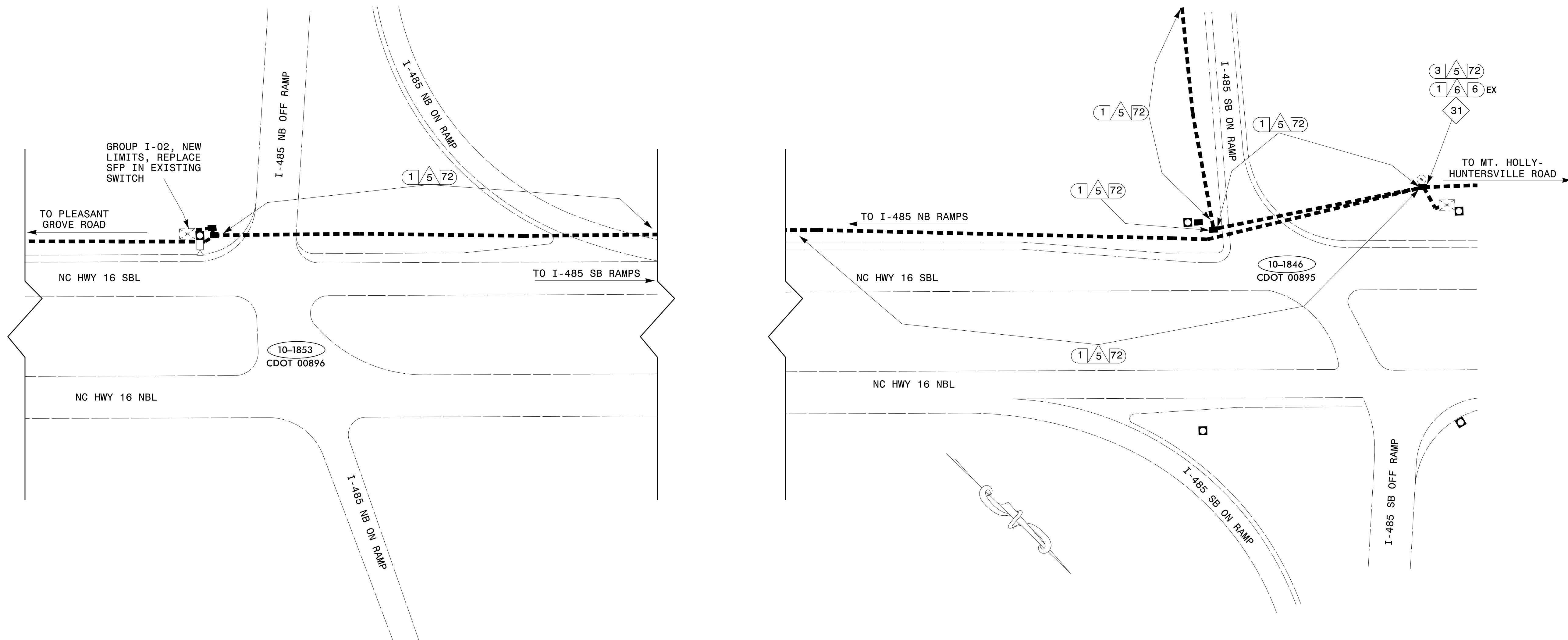

CONSTRUCTION NOTES:

1. ALL EFFORTS SHALL BE MADE TO LIMIT THE AMOUNT OF DOWN TIME TO THE SYSTEM. PRIOR TO DISCONNECTION OF THE EXISTING FO CABLE, DOCUMENT AND TAKE PHOTOS OF EXISTING SPLICE.
2. CONTRACTOR TO RECORD EXISTING SPLICE ARRANGEMENT FOR COMPARISON TO THE SUPPLIED SPLICE DETAILS. IF DISCREPANCIES EXIST, CONTACT THE ENGINEER TO DETERMINE HOW TO PROCEED WITH REPLICING. PROVIDE AS-BUILT PLANS TO THE ENGINEER IF FINAL SPLICE ARRANGEMENT DIFFERS FROM THE SUPPLIED SPLICE DETAILS.
3. FIVE (5) DAYS PRIOR TO CUTTING ANY EXISTING FIBER AND FIVE (5) DAYS PRIOR TO BEGINNING WORK ON THE SIGNAL SYSTEM, CONTACT THE CHARLOTTE ENGINEERING PROJECT COORDINATOR, MARK ODEM, AT (980)230-1847 TO COORDINATE DOWN TIME FOR SIGNAL SYSTEM DUE TO THIS PROJECT. NOTIFY ENGINEERING PROJECT COORDINATOR AFTER ALL WORK PERFORMED TO ENSURE THAT ALL FIBER CIRCUITS ARE FUNCTIONING PROPERLY. WORK IS NOT COMPLETE UNTIL THE SIGNAL SYSTEM IS BACK UP AND OPERATIONAL.
4. COORDINATE WITH PROJECT I-5973. SPLICE 895 WILL BE MODIFIED UNDER BOTH PROJECTS AND MAY BE RELOCATED IN THE SAME QUADRANT UNDER I-5973. PROPOSED WORK UNDER I-5973 IS SHOWN AS EXISTING.

PROPOSED FIBER OPTIC ETHERNET SWITCHES & SFP OPTICS

TCB Location	Sheet	Intersection	Switch	Group	SFP 1		SFP 2	
					Status	Range	Status	Range
TCB 10-0659/0938	SCP 2	NC 16 (Brookshire Blvd) at Bellhaven Blvd	EXISTING	I-04	EXISTING*	70 KM	EXISTING*	10 KM
TCB 10-2403/01904	SCP 2	NC 16 (Brookshire Blvd) at Old Plank Road	NEW	I-04	NEW	10 KM	NEW	10 KM
TCB 10-2402/01905	SCP 3	NC 16 (Brookshire Blvd) SB at Old Plank Road U-turn	NEW	I-04	NEW	10 KM	NEW	10 KM
TCB 10-2401/01906	SCP 4	NC 16 (Brookshire Blvd) NB at Pleasant Grove Road U-turn	NEW	I-04	NEW	10 KM	NEW	10 KM
TCB 10-0880/0940	SCP 4	NC 16 (Brookshire Blvd) at Pleasant Grove Road	NEW	I-04	NEW	10 KM	NEW	10 KM
TCB 10-2400/01907	SCP 5	NC 16 (Brookshire Blvd) SB at Pleasant Grove Road U-turn	NEW	I-04	NEW	10 KM	NEW	70 KM
TCB 10-1853/0896	SCP 6	NC 16 (Brookshire Blvd) at I-485 NB Ramp	EXISTING	I-02	NEW	70 KM	EXISTING*	10 KM
TCB 10-1846/0895	SCP 6	NC 16 (Brookshire Blvd) at I-485 SB Ramp	EXISTING	I-04	EXISTING*	10 KM	EXISTING*	10 KM
Old City Hall	NA	NA	EXISTING	I-04	NEW **	70 KM	-	-
NCDOT Hub 6	NA	NA	EXISTING	I-04	NEW **	10 KM	-	-

Note: All SFP's shall be 1GB Optic

* FOR INFORMATION ONLY

** PROVIDE SFP AND JUMPERS TO THE CITY. CITY WILL INSTALL IN APPROPRIATE LOCATION.

TO COMPLETE THE CIRCUIT FOR NEW GROUP I-04, CDOT WILL INSTALL THE APPROPRIATE SFPs AND JUMPERS AT OLD CITY HALL AND AT NCDOT HUB 6, LOCATED AT THE INTERCHANGE OF I-485 AND I-85. FOR INFORMATIONAL PURPOSES ONLY, THE SPLICE OUTSIDE HUB 6 AND THE CDOT SWITCH INSIDE HUB 6 IS SHOWN ON SHEETS SCP 16 AND SCP 17.

THE CONTRACTOR WILL BE RESPONSIBLE FOR SUPPLYING APPROPRIATE SMALL FORM-FACTOR PLUG-ABLE (SFP) OPTICS AND JUMPERS FOR USE AT OLD CITY HALL AND NCDOT HUB 6.



City of Charlotte
Department of Transportation
600 East Fourth Street
Charlotte, North Carolina 28202
Phone: (704) 336-4119



REVISIONS

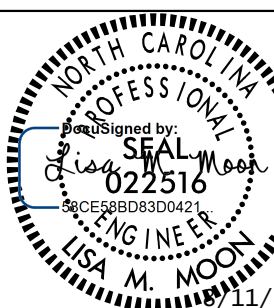

11/2022

DOCUMENT NOT CONSIDERED FINAL UNLESS ALL SIGNATURES COMPLETED

Plans Prepared By:
DRMP
DRMP, Inc.
8000 Regency Parkway, Suite 110
Charlotte, NC 28213 (704) 655-1038
NC License No. 02213

1" = 50'	SCALE
10-1853, 10-1846	NCDOT SIGNAL ID
C. Silver	CHECKED BY
AUGUST 2022	DATE

W-5710AK	JOB NO.
895, 896	SIGNAL ID
D. White	PREPARED BY
L. Moon	APPROVED BY

SIGNAL COMMUNICATION PLAN LAYOUT

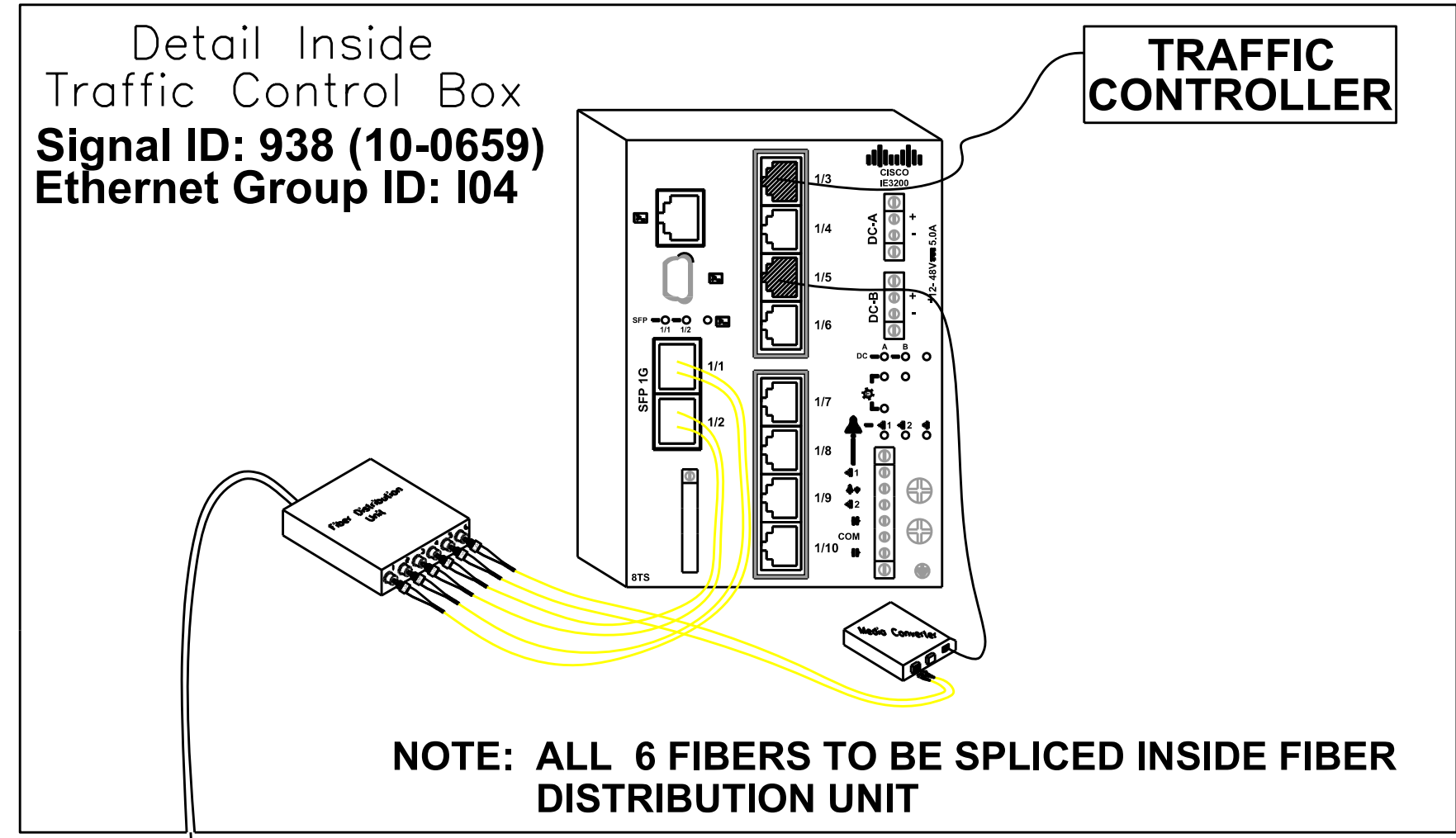

SPLICE 00938

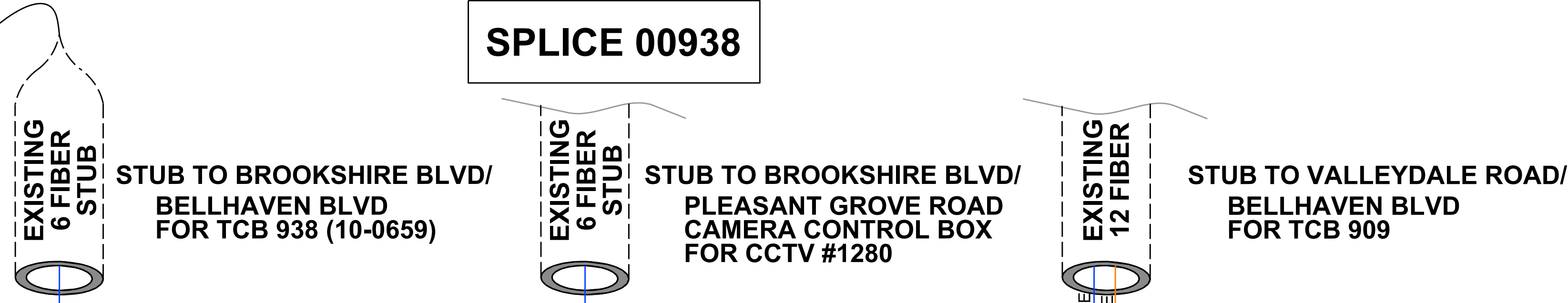

LEGEND

- EXISTING SPLICE
- NEW SPLICE

ALL UNUSED FIBERS ARE TO BE EXPRESSED THROUGH

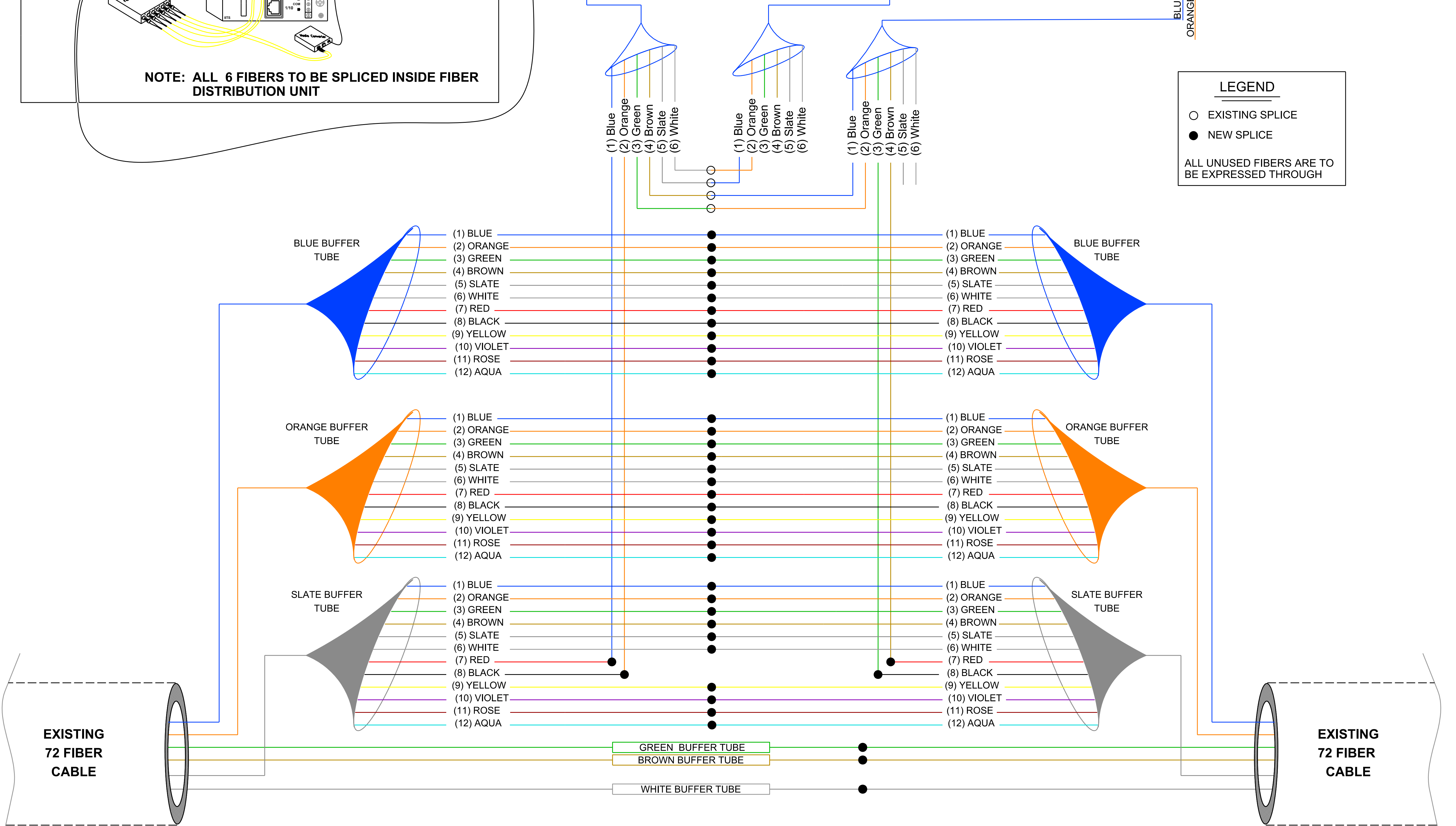

TO/FROM RTMS UNIT AT EX HH# 10.5 FOR TCB 824

SPLICE CASE IN HANDHOLE EX-HH#12 AT BROOKSHIRE BLVD AND BELLHAVEN BLVD

TO/FROM HH#13 AT OLD RTMS UNIT #5 FOR TCB 1904 (10-2403)

CHARLOTTE

City of Charlotte
Department of Transportation
600 East Fourth Street
Charlotte, North Carolina 28202
Phone: (704) 336-4119

Plans Prepared For:

REVISIONS

DRMP
DRMP, Inc.
8000 Regency Parkway, Suite 110
Charlotte, NC 28226
NC License No. C-22713 (819) 850-1038

W-57/0AK JOB NO.	NA SCALE	NA SIGNAL ID	C. Silver CHECKED BY	AUGUST 2022 DATE
D. White PREPARED BY	L. Moon APPROVED BY			

SIGNAL COMMUNICATION PLAN
SPLICE DIAGRAMS

SHEET SCP 7 OF SCP 17

LEGEND

○ EXISTING SPLICE
● NEW SPLICE

ALL UNUSED FIBERS ARE TO BE EXPRESSED THROUGH

SPLICE 01904

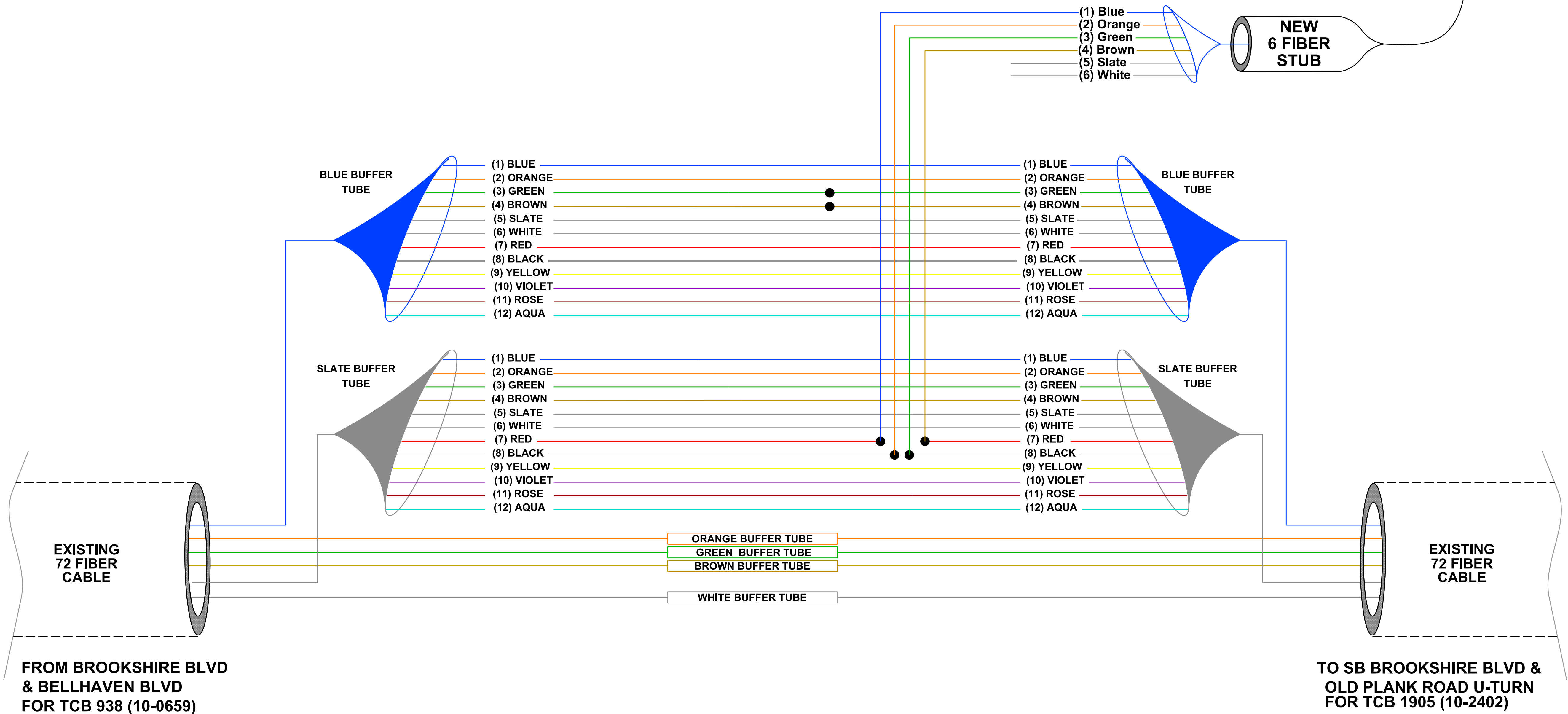
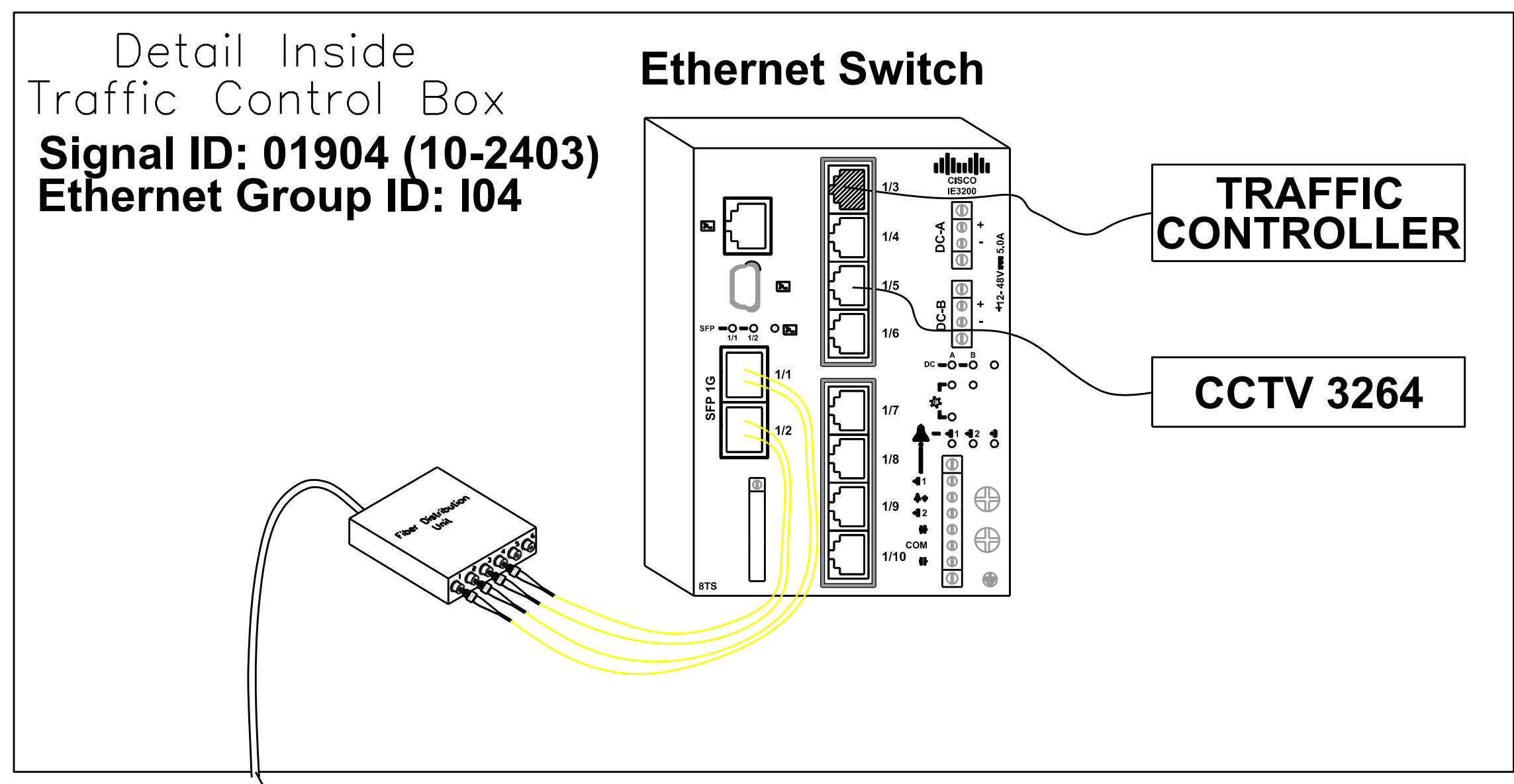

SPLICE CASE IN EX. HANDHOLE# 13 ON SB BROOKSHIRE BLVD AT ~300' NORTH OF OLD PLANK ROAD



Plans Prepared For:
City of Charlotte
Department of Transportation
600 East Fourth Street
Charlotte, North Carolina 28202
Phone: (704) 336-4119



REVISIONS

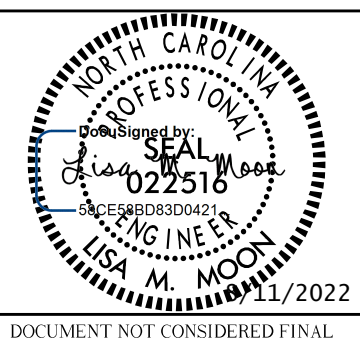

DOCUMENT NOT CONSIDERED FINAL UNLESS ALL SIGNATURES COMPLETED

Plans Prepared By:
DRMP
DRMP, Inc.
8000 Regency Parkway, Suite 110
Charlotte, NC 28213
NC License No. C-2713 (819) 855-1038

NA	SCALE	10-2403	NC DOT SIGNAL ID	C. Silver	CHECKED BY	AUGUST 2022	DATE
W-57/OAK	JOB NO.	NA	Signal ID	D. White	PREPARED BY	L. Moon	APPROVED BY

SIGNAL COMMUNICATION PLAN
SPLICE DIAGRAMS

BUTT SPLICE IN HH13.1 ON BROOKSHIRE BLVD

LEGEND

○ EXISTING SPLICE
● NEW SPLICE

ALL UNUSED FIBERS ARE TO BE EXPRESSED THROUGH

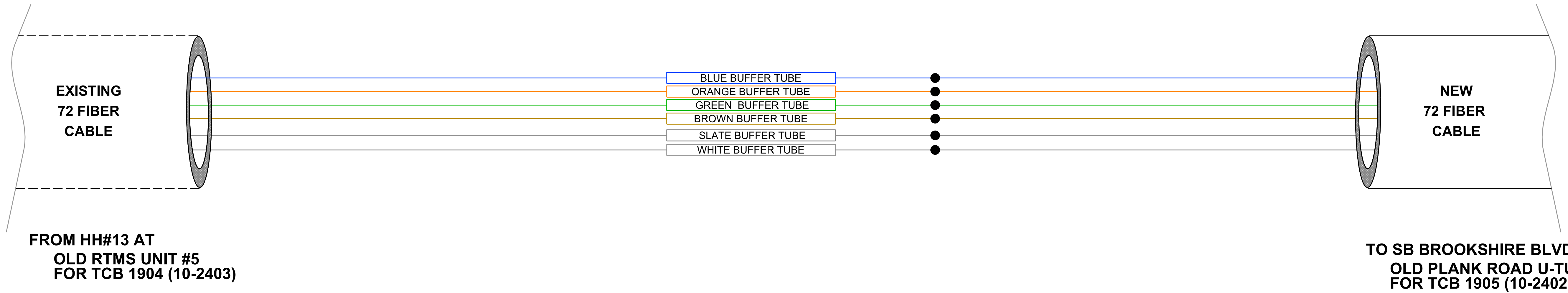

SPLICE CASE IN HANDHOLE #13.1 ON BROOKSHIRE BLVD ~1100' NORTH OF OLD PLANK ROAD



Plans Prepared For:
City of Charlotte
 Department of Transportation
 600 East Fourth Street
 Charlotte, North Carolina 28202
 Phone: (704) 336-4119



REVISIONS

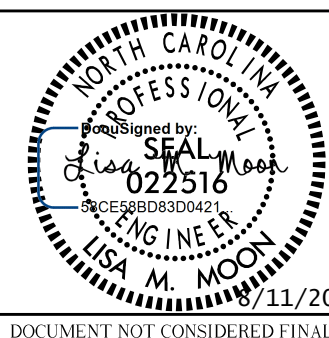

DOCUMENT NOT CONSIDERED FINAL UNLESS ALL SIGNATURES COMPLETED

Plans Prepared By:
DRMP
 DRMP, Inc.
 8000 Regency Parkway, Suite 110
 NC License No. C-2213 (819) 850-1038

W-57/0AK JOB NO.	NA	SCALE	NA
NA	NA	NC DOT SIGNAL ID	NA
D. White PREPARED BY	C. Silver	CHECKED BY	AUGUST 2022
L. Moon APPROVED BY		DATE	

SIGNAL COMMUNICATION
 PLAN
 SPLICE DIAGRAMS

LEGEND

- EXISTING SPLICE
- NEW SPLICE

ALL UNUSED FIBERS ARE TO BE EXPRESSED THROUGH

SPLICE 01905

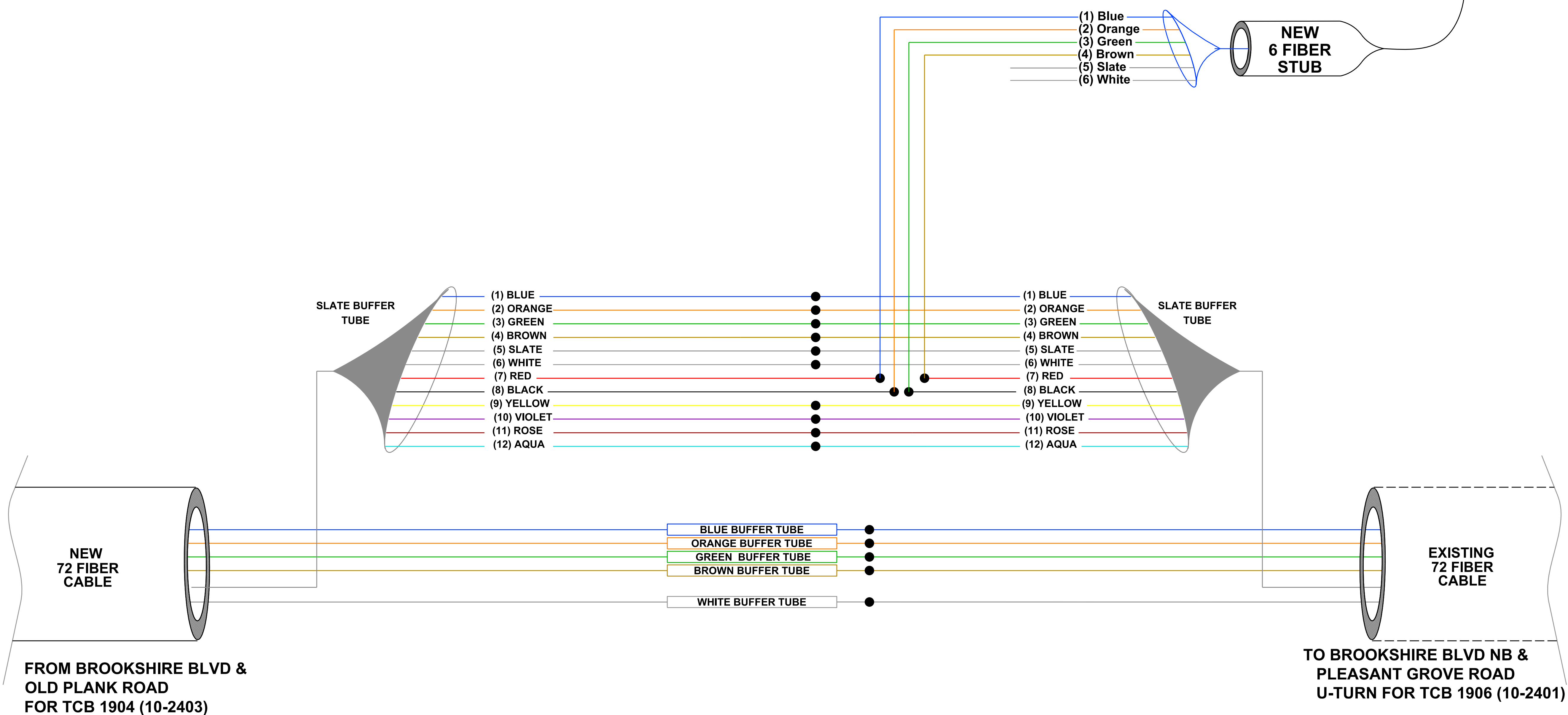
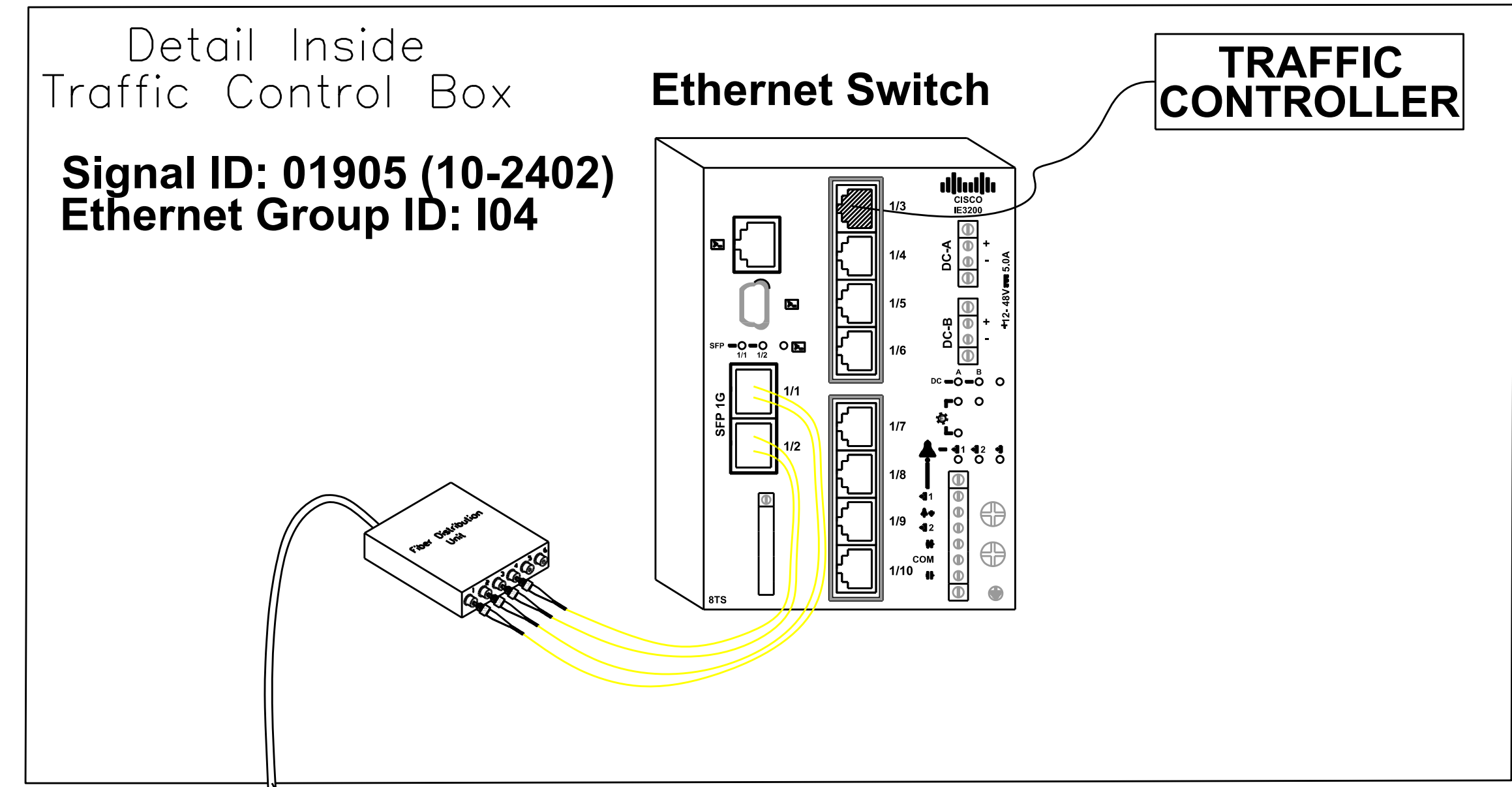

SPLICE CASE IN EX HANDHOLE# 13.3 ON SB BROOKSHIRE BLVD AT OLD PLANK ROAD U-TURN



Plans Prepared For:
City of Charlotte
 Department of Transportation
 600 East Fourth Street
 Charlotte, North Carolina 28202
 Phone: (704) 336-4119



REVISIONS

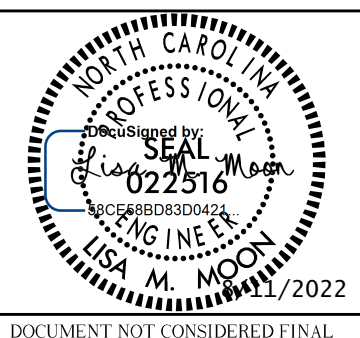

DOCUMENT NOT CONSIDERED FINAL UNLESS ALL SIGNATURES COMPLETED

Plans Prepared By:
DRMP
 DRMP, Inc.
 8000 Regency Parkway, Suite 110
 NC License No. C-2213 (819) 850-1038

NA	SCALE	100% 100/100	NC DOT SIGNAL ID	C. Silver	CHECKED BY	AUGUST 2022	DATE
W-57/0AK	JOB NO.	NA	Signal ID	D. White	PREPARED BY	L. Moon	APPROVED BY

SIGNAL COMMUNICATION PLAN
 SPLICE DIAGRAMS

LEGEND

- EXISTING SPLICE
- NEW SPLICE

ALL UNUSED FIBERS ARE TO BE EXPRESSED THROUGH

SPLICE 01906

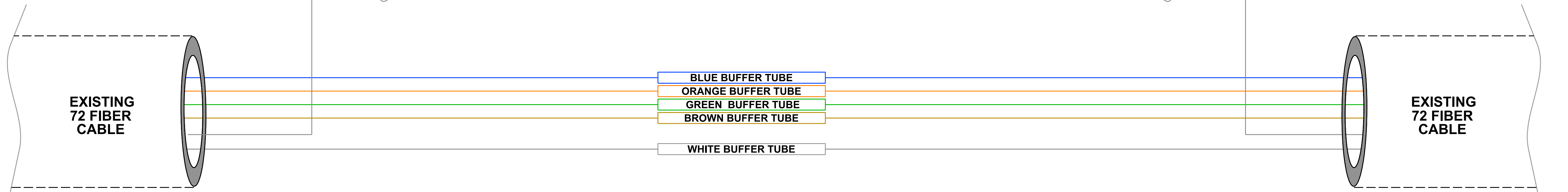
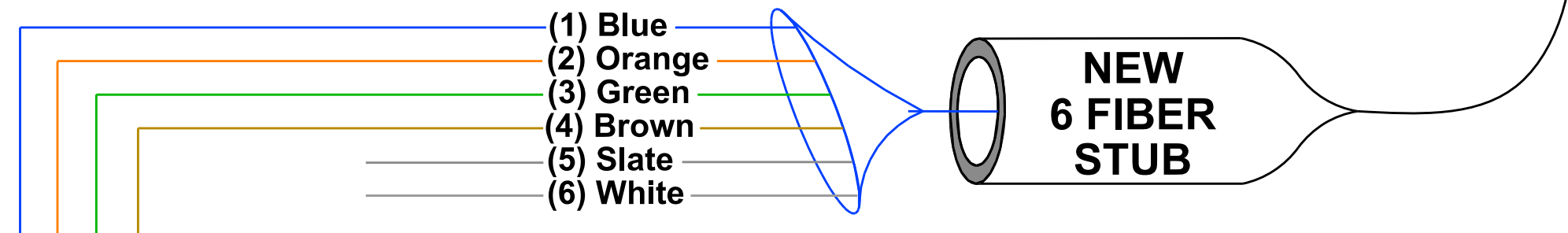
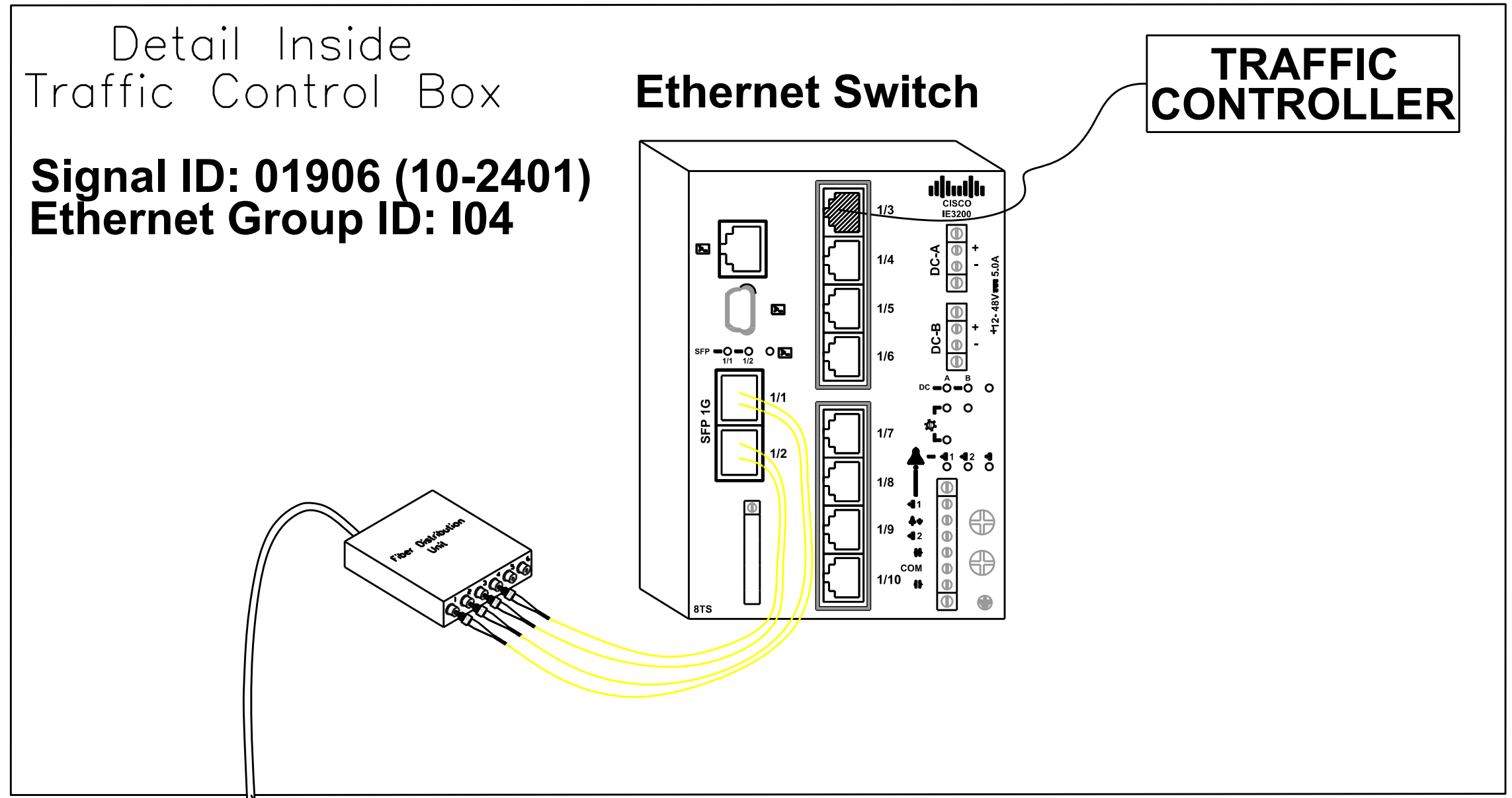

FROM SB BROOKSHIRE BLVD & OLD PLANK ROAD U-TURN FOR TCB 1905 (10-2402)

SPLICE CASE IN HANDHOLE# 15 ON NB BROOKSHIRE BLVD AT PLEASANT GROVE RD U-TURN

TO BROOKSHIRE BLVD & PLEASANT GROVE ROAD FOR TCB 940 (10-0880)



Plans Prepared For:
City of Charlotte
Department of Transportation
600 East Fourth Street
Charlotte, North Carolina 28202
Phone: (704) 336-4119



REVISIONS



DOCUMENT NOT CONSIDERED FINAL UNLESS ALL SIGNATURES COMPLETE

Plans Prepared By:
DRMP
DRMP, Inc.
8000 Regency Parkway, Suite 110
Charlotte, NC 28213 | (704) 655-1038
NC License No. C-2713

W-57/0AK	NA	SCALE	DATE
JOB NO.	10-2401	NC DOT SIGNAL ID	AUGUST 2022
Signal ID	C. Silver	CHECKED BY	
D. White		APPROVED BY	
PREPARED BY	L. Moon		

SIGNAL COMMUNICATION PLAN
SPLICE DIAGRAMS

SHEET SCP 11 OF SCP 17

LEGEND

- EXISTING SPLICE
- NEW SPLICE

ALL UNUSED FIBERS ARE TO BE EXPRESSED THROUGH

SPLICE 00940

STUB TO BROOKSHIRE BLVD/
PLEASANT GROVE ROAD
CAMERA CONTROL BOX
FOR CCTV #1281

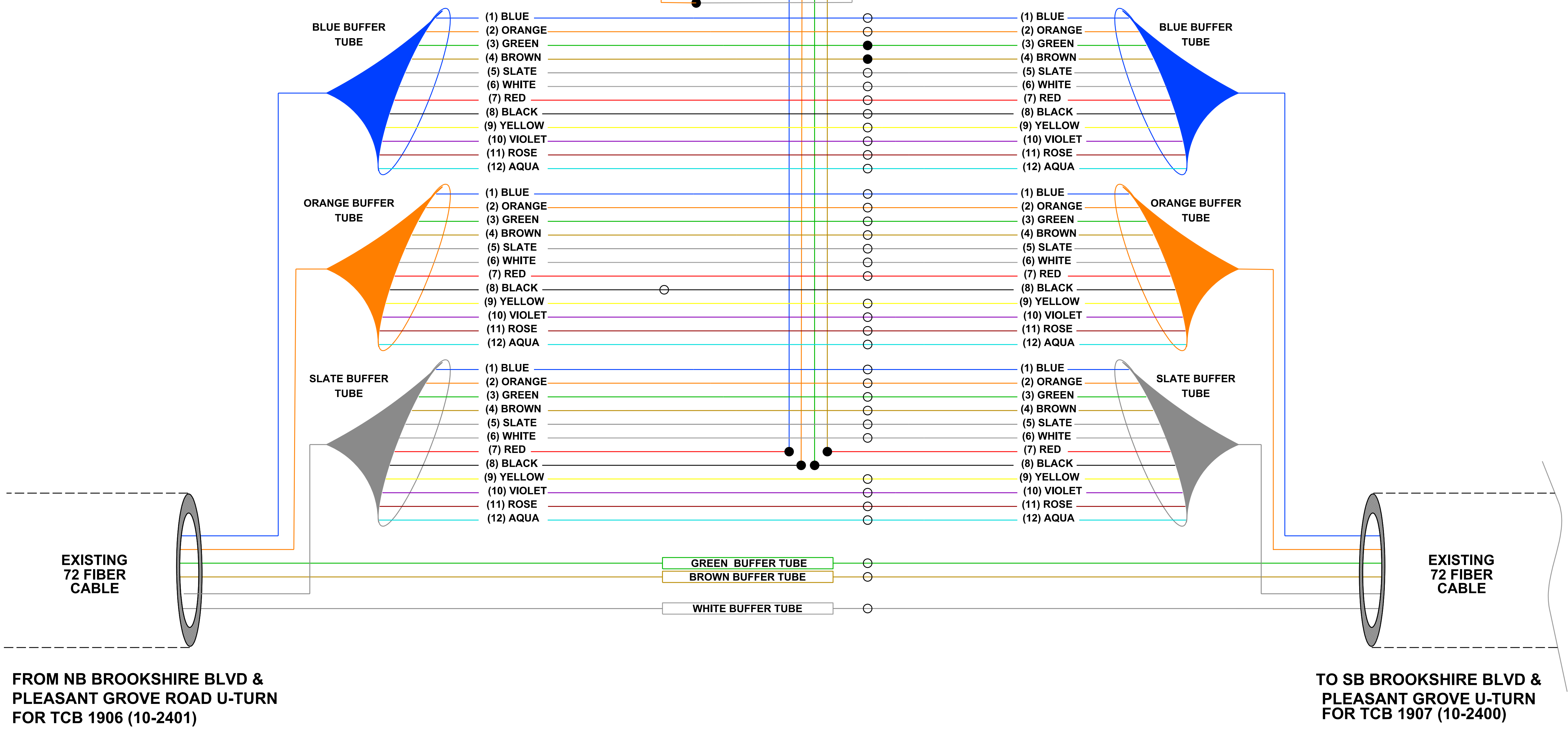
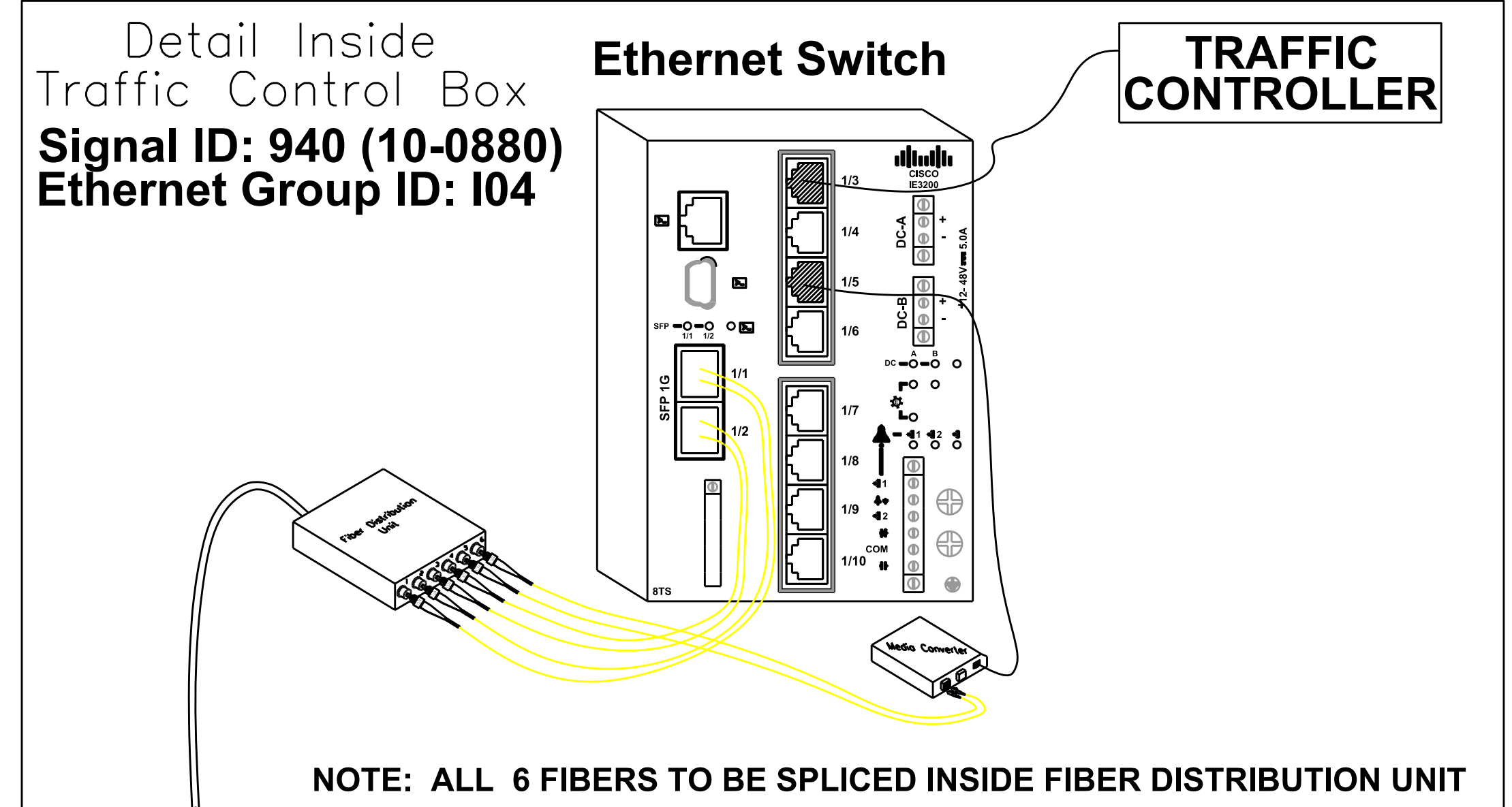
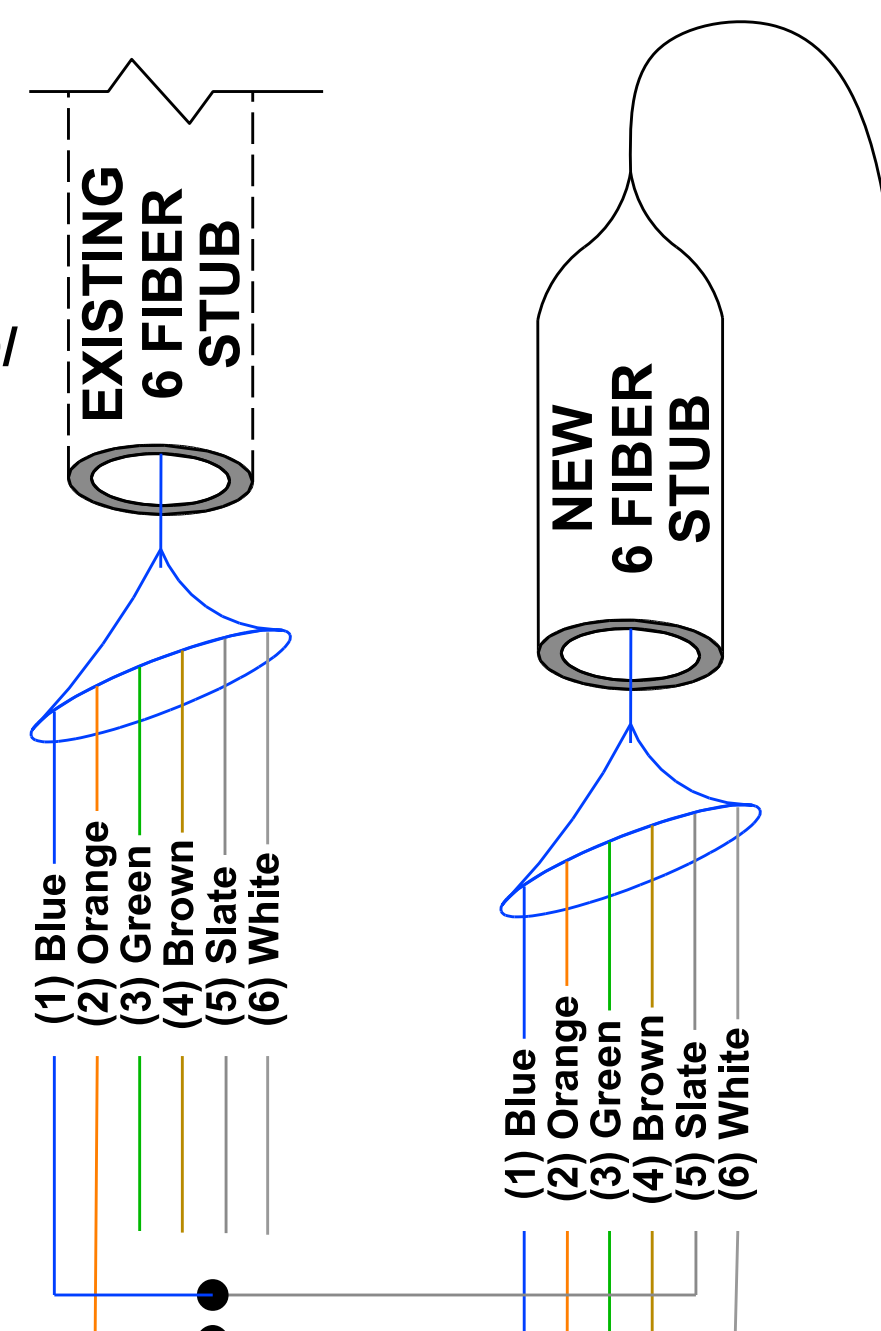

SPLICE CASE IN HANDHOLE# 16 ON BROOKSHIRE BLVD AT PLEASANT GROVE ROAD



City of Charlotte
Department of Transportation
600 East Fourth Street
Charlotte, North Carolina 28202
Phone: (704) 336-4119



REVISIONS

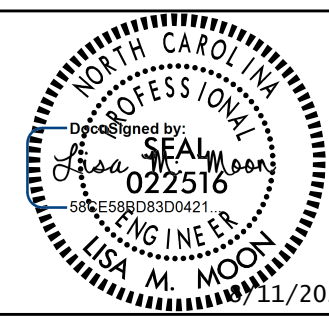

DOCUMENT NOT CONSIDERED FINAL UNLESS ALL SIGNATURES COMPLETED

Plans Prepared By:

DRMP, Inc.
8000 Regency Parkway, Suite 110
NC License No. C-2713 (819) 850-1038

NA	SCALE	10-0880	NC DOT SIGNAL ID	C. Silver	CHECKED BY	AUGUST 2022	DATE
W-5770AK	JOB NO.	NA	Signal ID	D. White	PREPARED BY	L. Moon	APPROVED BY

SIGNAL COMMUNICATION PLAN
SPLICE DIAGRAMS

SHEET SCP 12 OF SCP 17

SHEET INTENTIONALLY LEFT BLANK.



SHEET
SCP 13
OF
SCP 17

SIGNAL COMMUNICATION
PLAN
SPICE DIAGRAMS

W-57(OAK) JOB NO.	NA	SCALE	NA
Signal ID	NA	NC DOT SIGNAL ID	NA
PREPARED BY	D. White	CHECKED BY	C. Silver
APPROVED BY	L. Moon	DATE	AUGUST 2022

Plans Prepared By:



DRMP
DRMP, Inc.
8000 Regency Parkway, Suite 110
NC License No. C-2213 (819) 855-1038

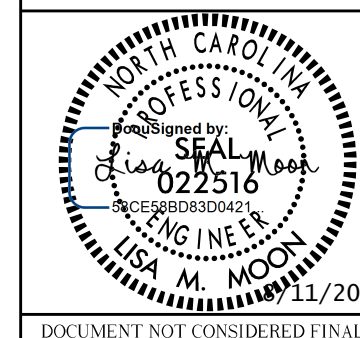

REVISIONS

Plans Prepared For:



City of Charlotte
Department of Transportation
600 East Fourth Street
Charlotte, North Carolina 28202
Phone: (704) 336-4119

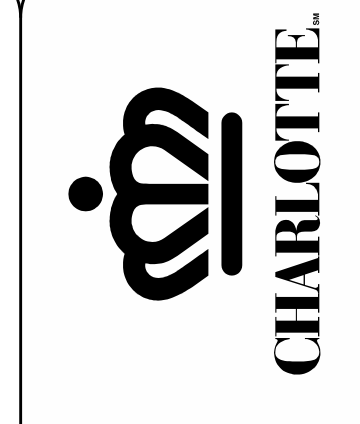

LEGEND

○ EXISTING SPLICE
● NEW SPLICE

ALL UNUSED FIBERS ARE TO BE EXPRESSED THROUGH

SPLICE 01907

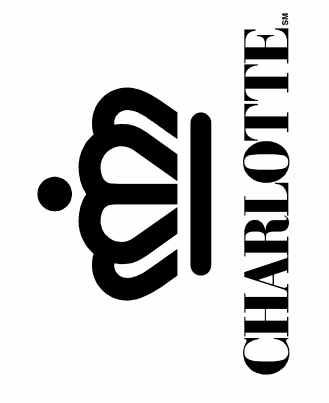
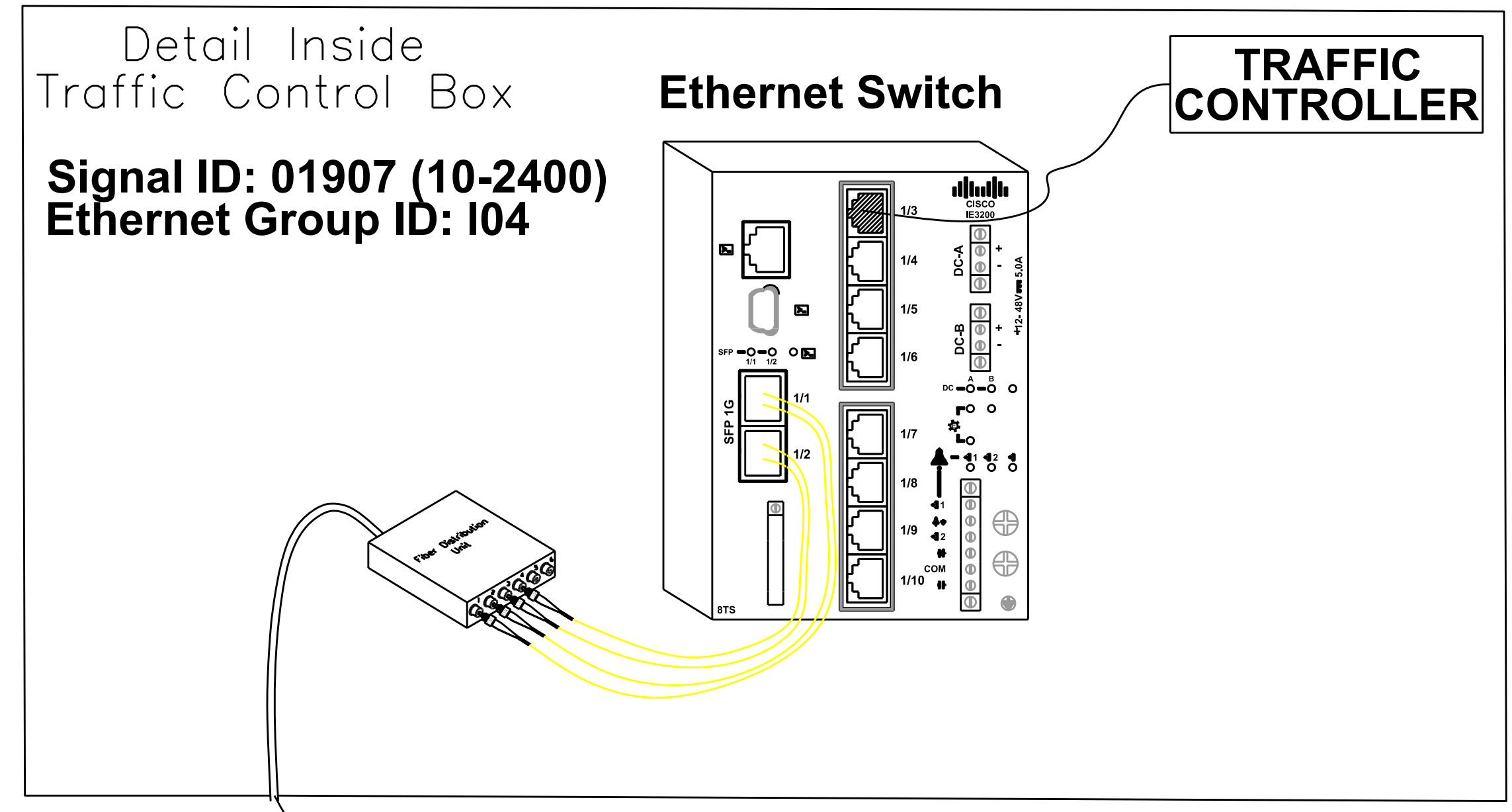

Plans Prepared For:
City of Charlotte
Department of Transportation
600 East Fourth Street
Charlotte, North Carolina 28202
Phone: (704) 336-4119



REVISIONS

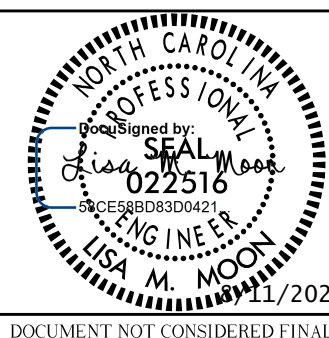

DOCUMENT NOT CONSIDERED FINAL UNLESS ALL SIGNATURES COMPLETED

Plans Prepared By:
DRMP
DRMP, Inc.
8000 Regency Parkway, Suite 110
Charlotte, NC 28213 (704) 850-1038
NC License No. C-2213

W-57/0AK	NA	SCALE	NA
JOB NO.	10-2400	NC DOT SIGNAL ID	C. Silver
NA	Signal ID	CHECKED BY	AUGUST 2022
D. White	PREPARED BY	DATE	
L. Moon	APPROVED BY		

SIGNAL COMMUNICATION PLAN
SPLICE DIAGRAMS

SHEET SCP 14 OF SCP 17

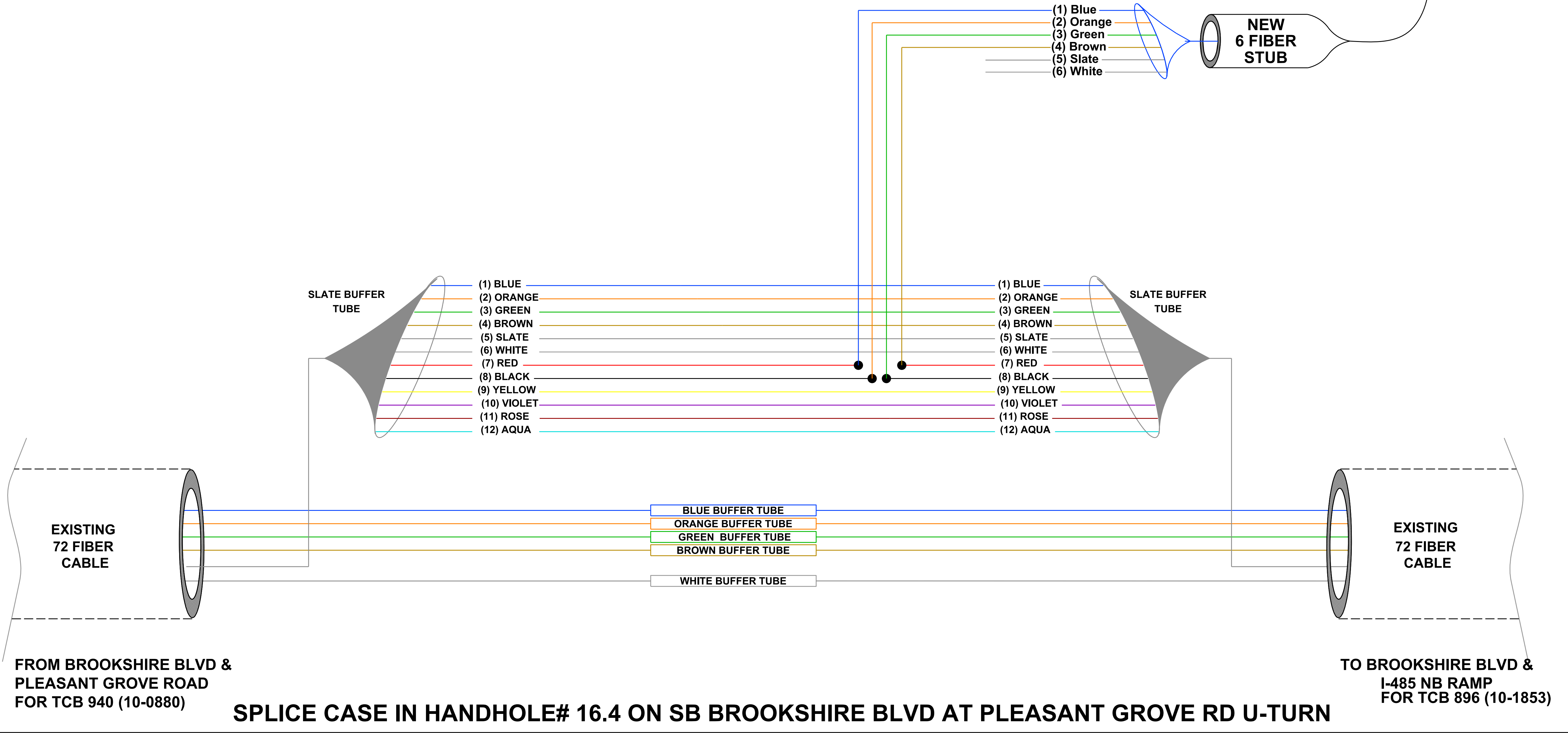

LEGEND

- EXISTING SPLICE
- NEW SPLICE

ALL UNUSED FIBERS ARE TO BE EXPRESSED THROUGH

SPLICE 00895

STUB TO BROOKSHIRE BLVD/
I-485 SB RAMP CONTROLLER
FOR TCB 895 (10-1856)

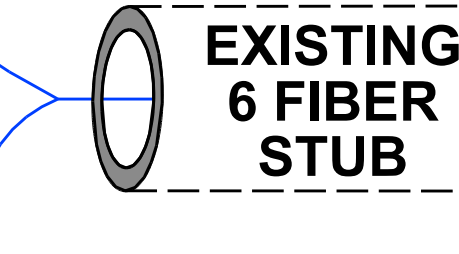

- (1) BLUE I1
- (2) ORANGE I1
- (3) GREEN I2
- (4) BROWN I2
- (5) SLATE
- (6) WHITE
- (7) RED 485 DIST
- (8) BLACK 485 DIST
- (9) YELLOW
- (10) VIOLET
- (11) ROSE
- (12) AQUA



- (1) BLUE
- (2) ORANGE
- (3) GREEN
- (4) BROWN
- (5) SLATE
- (6) WHITE
- (7) RED
- (8) BLACK
- (9) YELLOW
- (10) VIOLET
- (11) ROSE
- (12) AQUA



- (1) BLUE I29
- (2) ORANGE I29
- (3) GREEN
- (4) BROWN
- (5) SLATE
- (6) WHITE
- (7) RED I4
- (8) BLACK I4
- (9) YELLOW
- (10) VIOLET
- (11) ROSE
- (12) AQUA



- (1) BLUE I1
- (2) ORANGE I1
- (3) GREEN I2
- (4) BROWN I2
- (5) SLATE
- (6) WHITE
- (7) RED I4
- (8) BLACK 485 DIST
- (9) YELLOW
- (10) VIOLET
- (11) ROSE
- (12) AQUA



- (1) BLUE I29
- (2) ORANGE I29
- (3) GREEN
- (4) BROWN
- (5) SLATE
- (6) WHITE
- (7) RED
- (8) BLACK
- (9) YELLOW
- (10) VIOLET
- (11) ROSE
- (12) AQUA



- (1) BLUE I2
- (2) ORANGE I2
- (3) GREEN I2
- (4) BROWN I2
- (5) SLATE
- (6) WHITE
- (7) RED
- (8) BLACK
- (9) YELLOW
- (10) VIOLET
- (11) ROSE
- (12) AQUA



- (1) BLUE
- (2) ORANGE
- (3) GREEN
- (4) BROWN
- (5) SLATE
- (6) WHITE
- (7) RED
- (8) BLACK
- (9) YELLOW
- (10) VIOLET
- (11) ROSE
- (12) AQUA



- (1) BLUE
- (2) ORANGE
- (3) GREEN
- (4) BROWN
- (5) SLATE
- (6) WHITE
- (7) RED
- (8) BLACK
- (9) YELLOW
- (10) VIOLET
- (11) ROSE
- (12) AQUA

TO BROOKSHIRE BLVD/
MT HOLLY-HUNTERSVILLE RD

FROM BROOKSHIRE BLVD/
I-485 NB RAMP

EXISTING
72 FIBER
CABLE

EXISTING
72 FIBER
CABLE

TO/FROM NCDOT HUB 6
AT I-485 & I-85

EXISTING
72 FIBER
CABLE

GREEN BUFFER TUBE
BROWN BUFFER TUBE
WHITE BUFFER TUBE

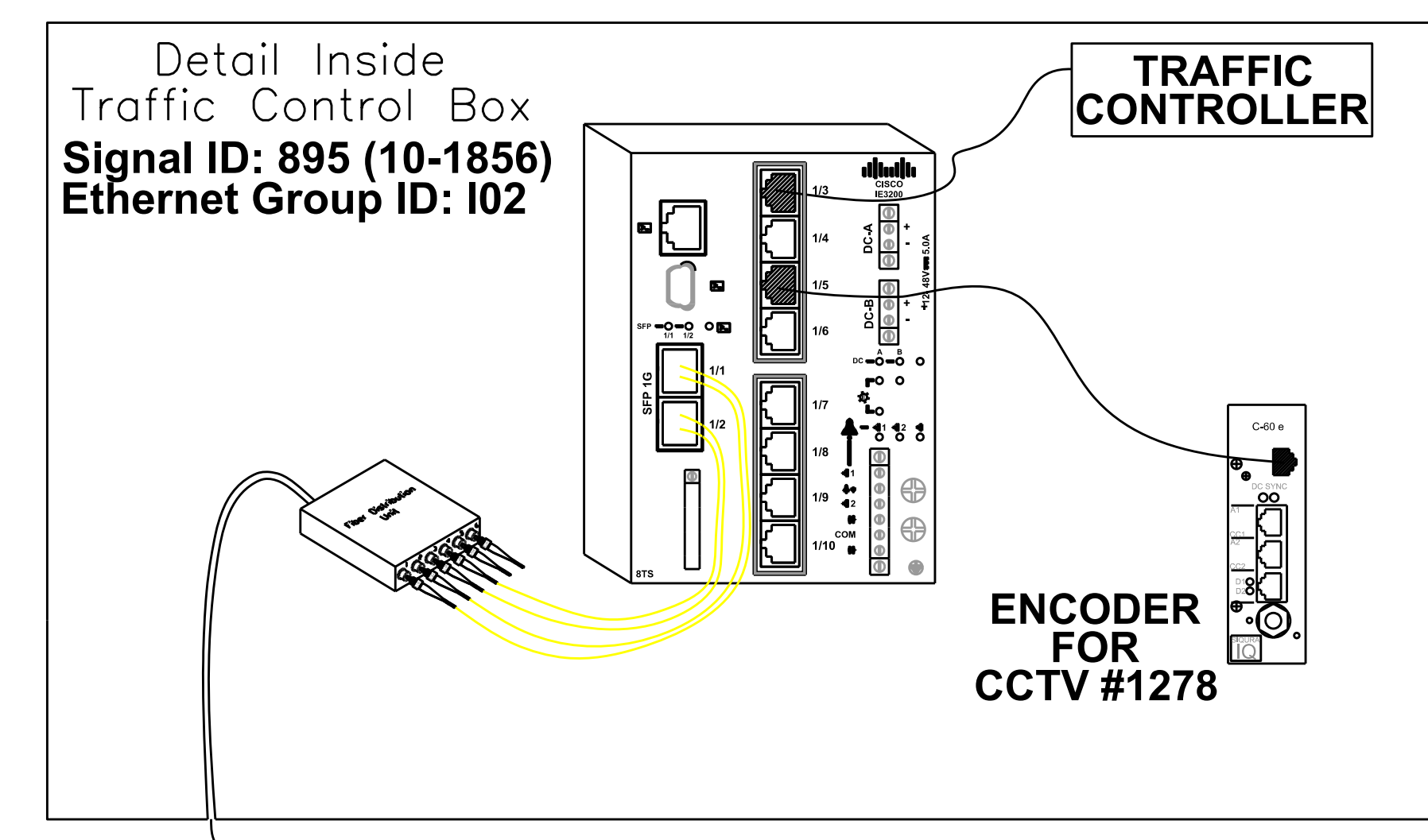

SPLICE CASE IN EX HANDHOLE AT BROOKSHIRE BLVD / I-485 SB RAMP



CHARLOTTE

Plans Prepared For:
City of Charlotte
 Department of Transportation
 600 East Fourth Street
 Charlotte, North Carolina 28202
 Phone: (704) 336-4119



REVISIONS

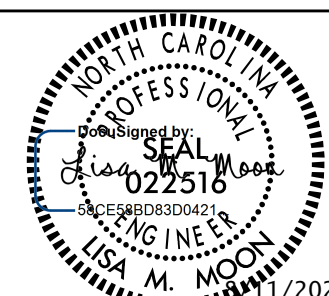

DOCUMENT NOT CONSIDERED FINAL
UNLESS ALL SIGNATURES COMPLETED

Plans Prepared By:

DRMP
 DRMP, Inc.
 8000 Regency Parkway, Suite 110
 NC License No. C-2213 (919) 850-0338

NA	SCALE	NA	DATE
W-57/0AK	NA	C. Silver	AUGUST 2022
JOB NO.	NA	CHECKED BY	
Signal ID	D. White	APPROVED BY	
	L. Moon		

SIGNAL COMMUNICATION PLAN

SPLICE DIAGRAMS

SHEET **SCP 15** OF **SCP 17**

NCDOT HUB 6 AT I-85

LEGEND

- EXISTING SPLICE
- NEW SPLICE

ALL UNUSED FIBERS ARE TO BE EXPRESSED THROUGH

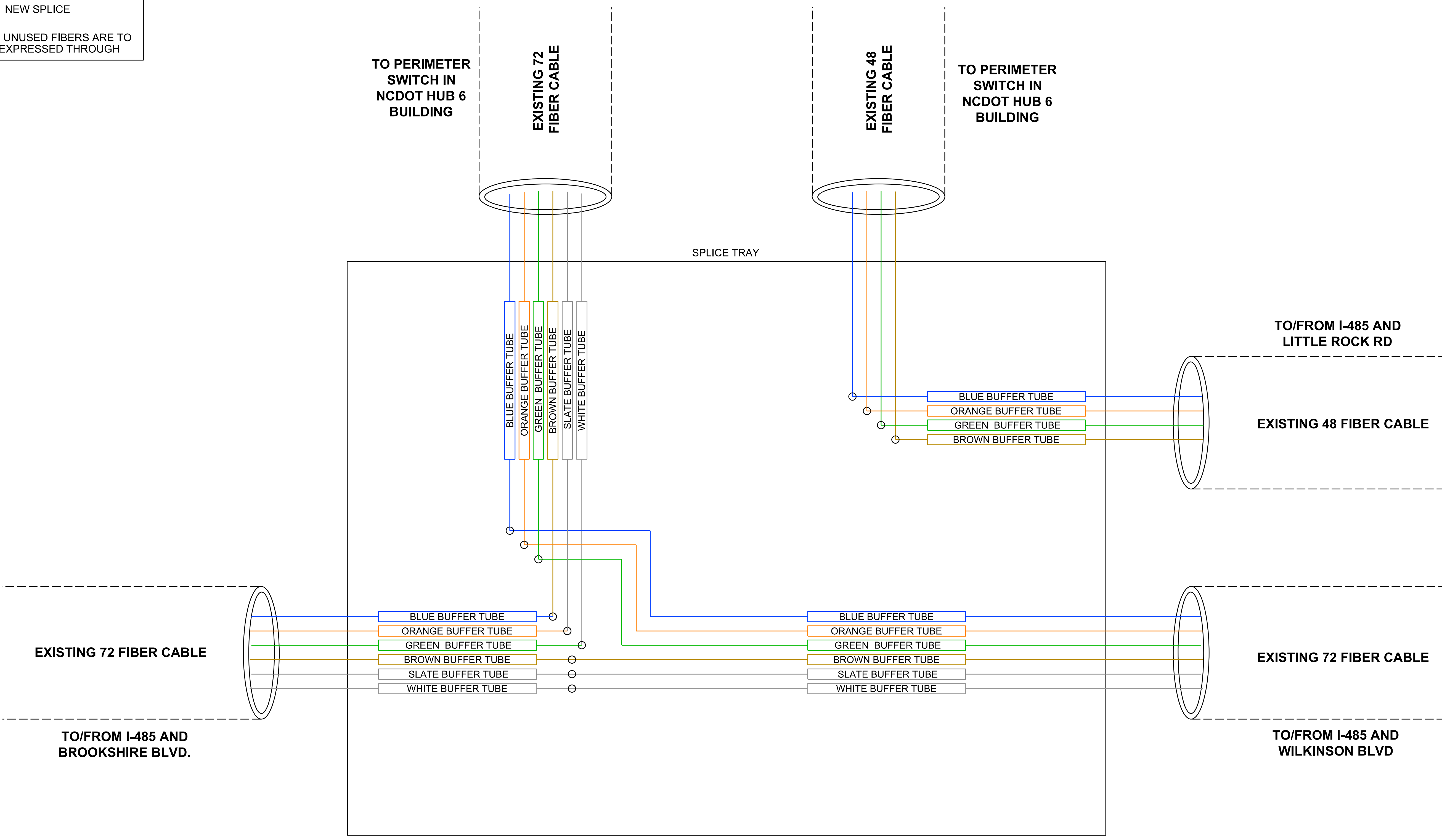

**EXISTING SPLICE CASE IN HANDHOLE AT NCDOT HUB 6 AT I-85 & I-485
(INFORMATION ONLY)**

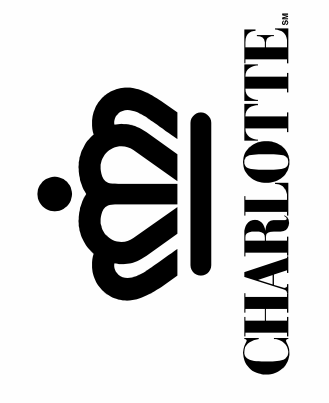

City of Charlotte
Department of Transportation
600 East Fourth Street
Charlotte, North Carolina 28202
Phone: (704) 336-4119



REVISIONS

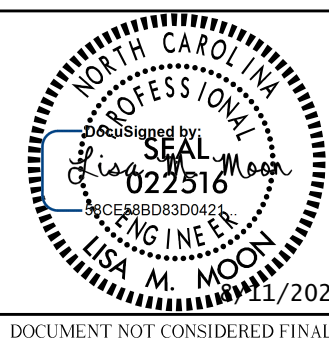

DOCUMENT NOT CONSIDERED FINAL UNLESS ALL SIGNATURES COMPLETE

Plans Prepared By:

DRMP

DRMP, Inc.
8000 Regency Parkway, Suite 110
Charlotte, NC 28213 (704) 655-1038
NC License No. C-2213

W-57/0AK JOB NO.	NA	SCALE	NA
NA Signal ID	NA	NCDOT SIGNAL ID	NA
D. White PREPARED BY	C. Silver	CHECKED BY	AUGUST 2022 DATE
L. Moon APPROVED BY			

SIGNAL COMMUNICATION
PLAN
SPLICE DIAGRAMS

PERIMETER SWITCH I-485 HUB

PERIMETER SWITCH TERMINATIONS
NCDOT HUB ON I-485
NORTH OF I-85/I-485 INTERCHANGE

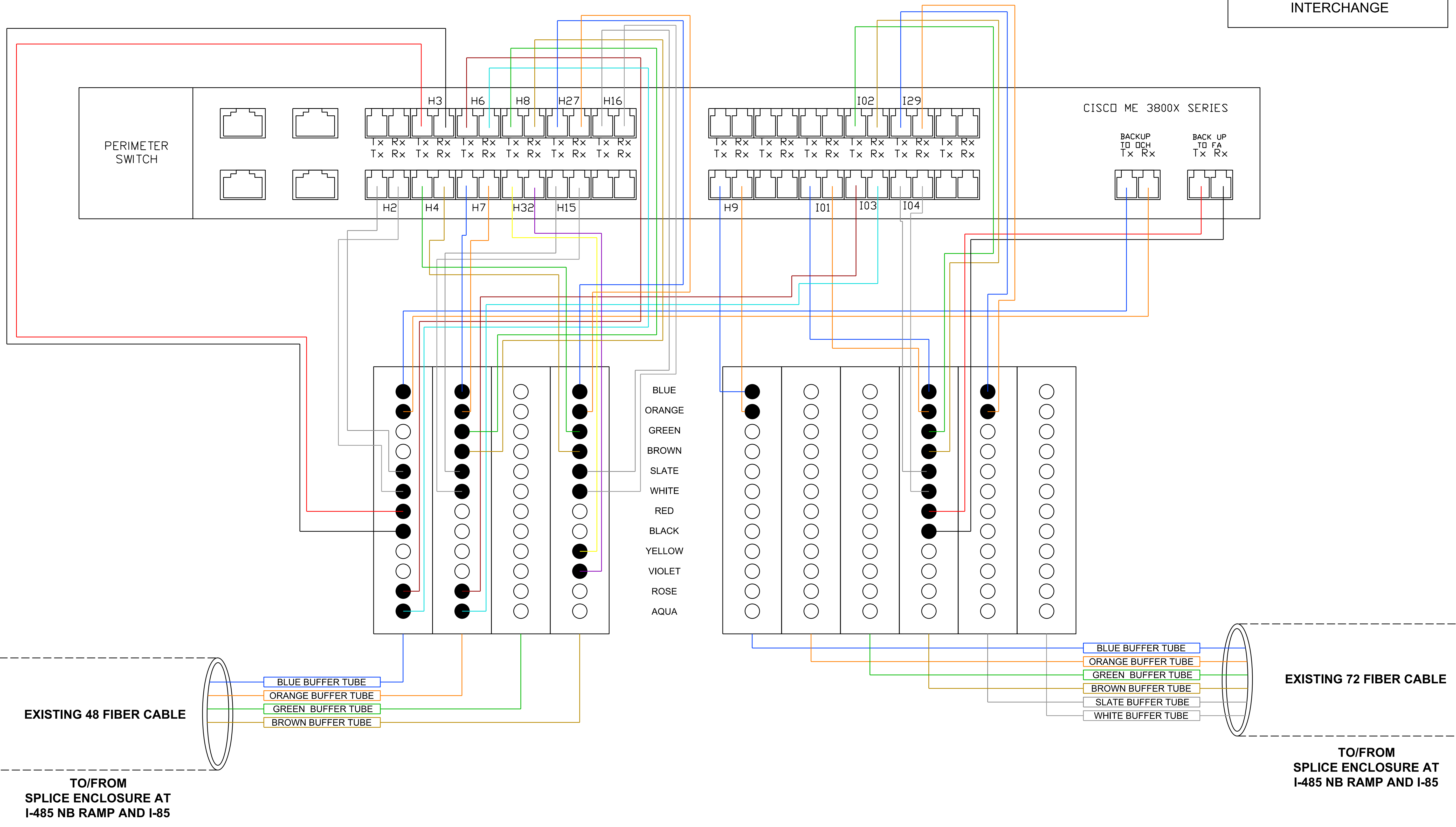

**EXISTING PERIMETER SWITCH IN NCDOT HUB 6 AT I-85 & I-485
(INFORMATION ONLY - CDOT TO MAKE CONNECTIONS)**



City of Charlotte
Department of Transportation
600 East Fourth Street
Charlotte, North Carolina 28202
Phone: (704) 336-4119



REVISIONS

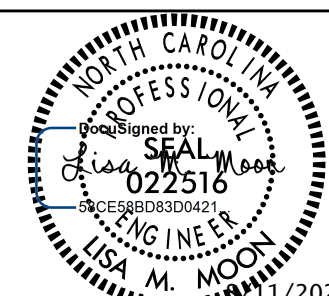

DOCUMENT NOT CONSIDERED FINAL UNLESS ALL SIGNATURES COMPLETED

Plans Prepared By:

DRMP, Inc.
8000 Regency Parkway, Suite 110
NC License No. C-2213 (819) 850-1038

NA	SCALE
NA	NCDOT SIGNAL ID
C. Silver	CHECKED BY
AUGUST 2022	DATE

W-5710AK	JOB NO.
NA	SIGNAL ID
D. White	PREPARED BY
L. Moon	APPROVED BY

**SIGNAL COMMUNICATION PLAN
SPICE DIAGRAMS**

**STATE OF NORTH CAROLINA
DEPARTMENT OF TRANSPORTATION**

**SIGNING PLAN
MECKLENBURG COUNTY**

**LOCATION: NC 16 AT OLD PLANK RD. (SR-2006) AND
PLEASANT GROVE RD. (SR-2008) RCI**

<small>PROJECT REFERENCE NO.</small> W-5710AK	<small>SHEET NO.</small> SIGN-01
<small>APPROVED:</small>	
<small>DATE:</small> 06/01/2022	
<small>SEAL</small> 	
<small>DOCUMENT NOT CONSIDERED FINAL UNLESS ALL SIGNATURES COMPLETED</small>	

T.I.P.: W-5710AK

ROADWAY STANDARD DRAWING

THE FOLLOWING ROADWAY STANDARDS AS APPEAR IN "ROADWAY STANDARD DRAWINGS" - PROJECT SERVICES UNIT - N.C. DEPARTMENT OF TRANSPORTATION - RALEIGH, N.C., DATED JANUARY 2018 ARE APPLICABLE TO THIS PROJECT AND BY REFERENCE HEREBY ARE CONSIDERED A PART OF THESE PLANS:

<u>STD. NO.</u>	<u>TITLE</u>
901.50	ARROWS AND SHIELDS
904.10	ORIENTATION OF GROUND MOUNTED SIGNS
904.50	MOUNTING OF TYPE 'D', 'E' AND 'F' SIGNS ON 'U' CHANNEL POSTS
910.30	SIGNING SIGNALIZED AND UNSIGNALIZED SUPERSTREET

GENERAL NOTES

- . SIGNS FURNISHED BY STATE
- . CONFIRM IN WRITING AT LEAST 4 MONTHS IN ADVANCE, THE ACTUAL DATE THE DEPARTMENT FURNISHED SIGNS WILL BE REQUIRED.
- . IF REMOVAL OR RELOCATION OF SIGNS ON PRIVATE STREET (NON-STATE MAINTAINED) IS REQUIRED DUE TO CONSTRUCTION, THE CONTRACTOR SHALL INFORM THE ENGINEER. THE WORK WILL BE COMPLETED BY OTHERS.
- . WHEN NOT STATIONED OR DIMENSIONED ON PLANS, ALL 'E' AND 'F' SIGNS SHALL BE FIELD LOCATED BY THE ENGINEER
- . ALL EXISTING SIGNS ON "U" CHANNEL POST WITHIN THE PROJECT LIMITS SHALL BE REMOVED AND DISPOSED OF UNLESS OTHERWISE NOTED ON PLANS.
- . WHEN EXISTING SIGNS ARE REMOVED AND INSTALLED ON NEW SUPPORTS, THE RE-ERECTION SHALL IMMEDIATELY FOLLOW THE REMOVAL.
- . THE BACKGROUND FOR TYPE E & F SIGNS SHALL BE TYPE C REFLECTIVE SHEETING.
- . SEE ROADWAY PLANS FOR GUARD/GUIDE RAIL DETAILS.

SUMMARY OF QUANTITIES

ITEM NO.		ITEM DESCRIPTION	QUANTITY	UNIT
DESC. NO.	SECT. NO.			
4072000000	903	SUPPORTS, 3 LB STEEL U-CHANNEL	1000	L.F.
4102000000	904	SIGN ERECTION, TYPE E	52	EA.
4108000000	904	SIGN ERECTION, TYPE F	15	EA.
4116100000	904	SIGN ERECTION, RELOCATE SIGN TYPE E (GROUND MOUNTED)	2	EA.
4238000000	907	DISPOSAL OF SIGN, D, E OR F	1	EA.
4155000000	907	DISPOSAL OF SIGN SYSTEM, U-CHANNEL	38	EA.
4192000000	907	DISPOSAL OF SUPPORT, U-CHANNEL	1	EA.

PROJECT NOTES

- 1 DISPOSAL OF SIGN SYSTEM, U-CHANNEL
- 2 DISPOSAL OF SIGN, D, E OR F
- 3 RELOCATE SIGN, TYPE E
- 4 DISPOSAL OF SUPPORT, U-CHANNEL



INDEX

<u>SHEET NO.</u>	<u>DESCRIPTION</u>
SIGN-1	TITLE SHEET
SIGN-2	TYPE "E" SIGNS
SIGN-3	TYPE "F" SIGNS
SIGN-4	SIGN DESIGNS
SIGN-5-8	SIGNING PLAN SHEETS

PLAN PREPARED BY: N.C.D.O.T. SIGNING AND DELINEATION UNIT

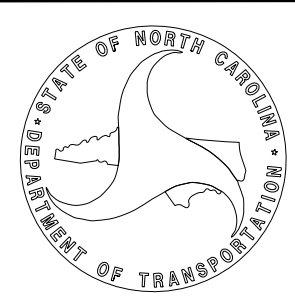
K. L. JORDAN SIGNING & DELINEATION REGIONAL ENGINEER
J. G. MARTINEZ, PE SIGNING & DELINEATION PROJECT DESIGN ENGINEER



PROJECT REFERENCE NO. W-5710AK	SHEET NO. SIGN-02
APPROVED:  4A70B418C88461	
DATE: 05/04/2022	
SEAL 	
DOCUMENT NOT CONSIDERED FINAL UNLESS ALL SIGNATURES COMPLETED	

401 QUANTITY REQ'D 1

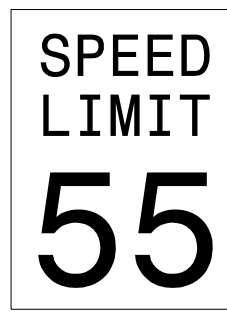

30" X 36"
R2-1

ONE "U" POSTS PER SIGN

406 QUANTITY REQ'D 2

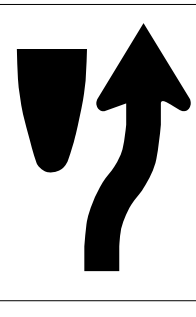

24" X 30"
R4-7

ONE "U" POST PER SIGN

411 QUANTITY REQ'D 2

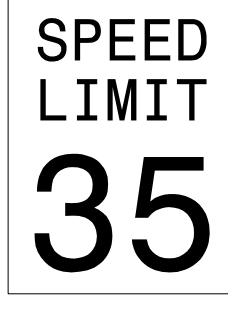

24" X 30"
R2-1

ONE "U" POST PER SIGN

402 QUANTITY REQ'D 4



42" X 30"
R5-1a

ONE "U" POST PER SIGN

407 QUANTITY REQ'D 2

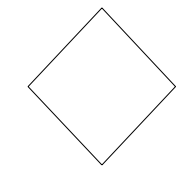

18" X 18"
OM1-3

MOUNT BELOW SIGN 406
IN 2 INSTALLATIONS

412 QUANTITY REQ'D 1



24" X 24"
R5-2

ONE "U" POST PER SIGN

403 QUANTITY REQ'D 8

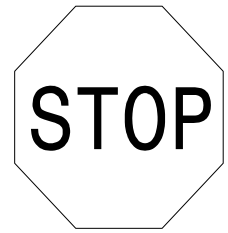

36" X 36"
R1-1

MOUNT BELOW SIGN 404
IN 4 INSTALLATIONS

ONE "U" POST PER SIGN

408 QUANTITY REQ'D 8



36" X 36"
R5-1

ONE "U" POST PER SIGN

413 QUANTITY REQ'D 1



24" X 12"
SEE SIGN DESIGN

MOUNT BELOW SIGN 412
IN 1 INSTALLATIONS

404 QUANTITY REQ'D 4



36" X 12"
R6-1 (R)

ONE "U" POST PER SIGN

409 QUANTITY REQ'D 8

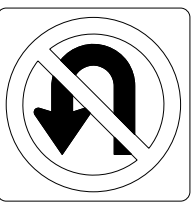

36" X 36"
R3-4

ONE "U" POST PER SIGN

405 QUANTITY REQ'D 4



54" X 18"
R6-1 (L)

TWO "U" POSTS PER SIGN

410 QUANTITY REQ'D 7

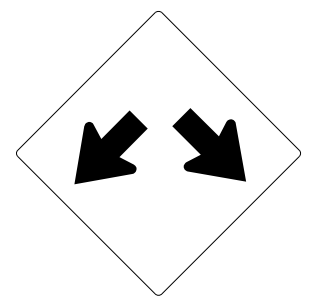

36" X 36"
W12-1

ONE "U" POST PER SIGN

TYPE "E" SIGNS

05/03/22 U:\Projects\2022 Sign Designs\Div 10\W-5710AK\W-5710AK_Signing.dgn

APPROVED: *Jose G. Martinez*
4A7DB418C88461...

DATE: 05/04/2022



**DOCUMENT NOT CONSIDERED FINAL
UNLESS ALL SIGNATURES COMPLETED**

501 508

TO 24" X 12"
SOUTH NORTH 2- 24" X 12"
16 16 2- 24" X 24"
21" X 21"
21" X 15"
AHEAD 24" X 12"

TWO "U" POSTS PER SIGN

506 514

TO 24" X 12"
SOUTH NORTH 2- 24" X 12"
16 16 2- 24" X 24"
2- 21" X 15"

TWO "U" POSTS PER SIGN

502 509

SOUTH 24" X 12"
16 24" X 24"
21" X 21"

ONE "U" POST PER SIGN

507 515

TO 24" X 12"
NORTH SOUTH 2- 24" X 12"
16 16 2- 24" X 24"
2- 21" X 15"

TWO "U" POSTS PER SIGN

503 510

NORTH 24" X 12"
16 24" X 24"

ONE "U" POST PER SIGN

513

SOUTH 24" X 12"
16 24" X 24"

ONE "U" POST PER SIGN

504 511

TO 24" X 12"
NORTH SOUTH 2- 24" X 12"
16 16 2- 24" X 24"
21" X 21"
21" X 15"
AHEAD 24" X 12"

TWO "U" POSTS PER SIGN

505 512

NORTH 24" X 12"
16 24" X 24"
21" X 21"

ONE "U" POST PER SIGN

TYPE "F" SIGNS

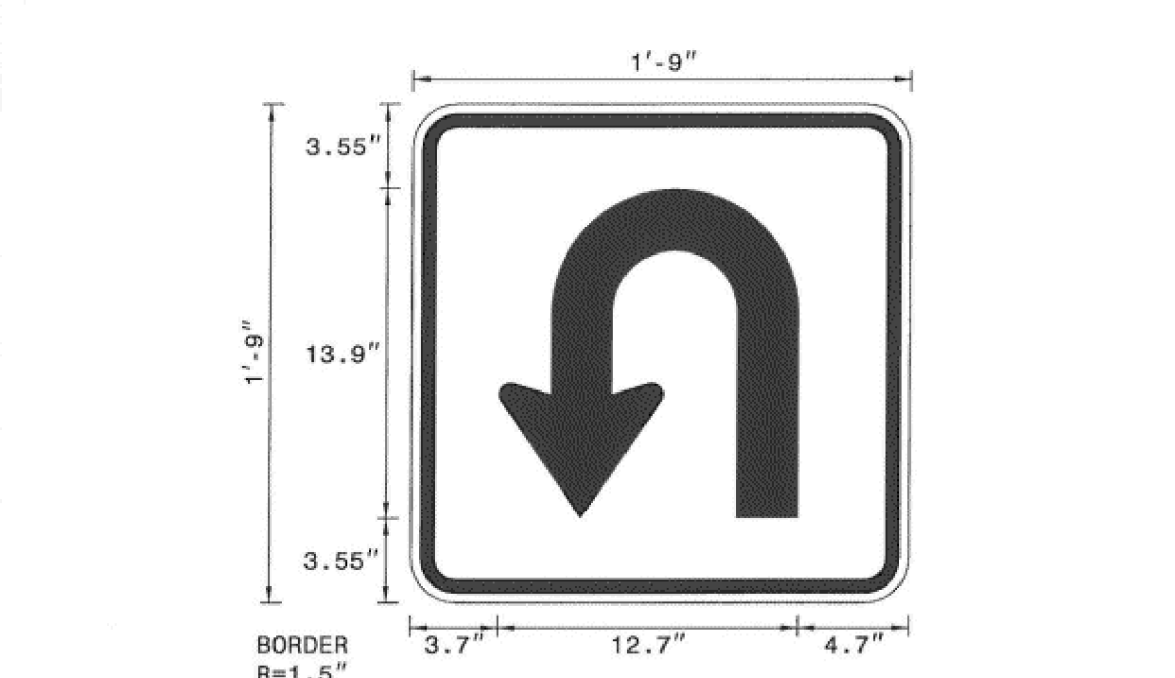
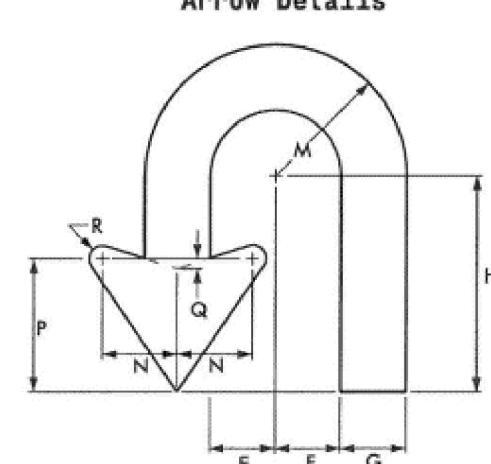
<p>SIGN NUMR: TYPE: F Ground QUANTITY: 1</p> <p>SIGN WIDTH: 1'-9" HEIGHT: 1'-9" TOTAL AREA: 3.1 Sq.Ft.</p> <p>MAT'L: 0.063" ALUMINUM</p> <p>BORDER TYPE: RECESSED RECESS: 0.38" WIDTH: 0.63" RADII: 1.5" NO. Z BARS: LENGTH:</p>	<p>BACKG. COLOR: White COPY COLOR: Black</p> <p>DESIGN BY: PROJECT ID:</p> <p>CHK BY: DIV:</p> <p>STD #: DATE:</p> <p style="text-align: right;">N. C. DEPARTMENT OF TRANSPORTATION DIVISION OF HIGHWAYS TRANSPORTATION MOBILITY & SAFETY SIGNING & DELINEATION UNIT</p>	 <p>BORDER R=1.5" TH=0.63" IN=0.38"</p>																		
<p>NOTES:</p> <ol style="list-style-type: none"> Legend and border shall be direct applied Non-reflective sheeting. Background shall be Grade C reflective sheeting. 																				
<p>Arrow Details</p>  <table border="1" style="margin: 10px auto;"> <thead> <tr> <th>ARROW DIMENSIONS (INCHES)</th> <th>F</th> <th>G</th> <th>H</th> <th>M</th> <th>N</th> <th>P</th> <th>Q</th> <th>R</th> </tr> </thead> <tbody> <tr> <td></td> <td>2.625</td> <td>2.625</td> <td>8.659</td> <td>5.25</td> <td>3</td> <td>5.25</td> <td>0.375</td> <td>0.5</td> </tr> </tbody> </table> <p>Spacing Factor is 1 unless specified otherwise FILENAME: GSENG</p>			ARROW DIMENSIONS (INCHES)	F	G	H	M	N	P	Q	R		2.625	2.625	8.659	5.25	3	5.25	0.375	0.5
ARROW DIMENSIONS (INCHES)	F	G	H	M	N	P	Q	R												
	2.625	2.625	8.659	5.25	3	5.25	0.375	0.5												

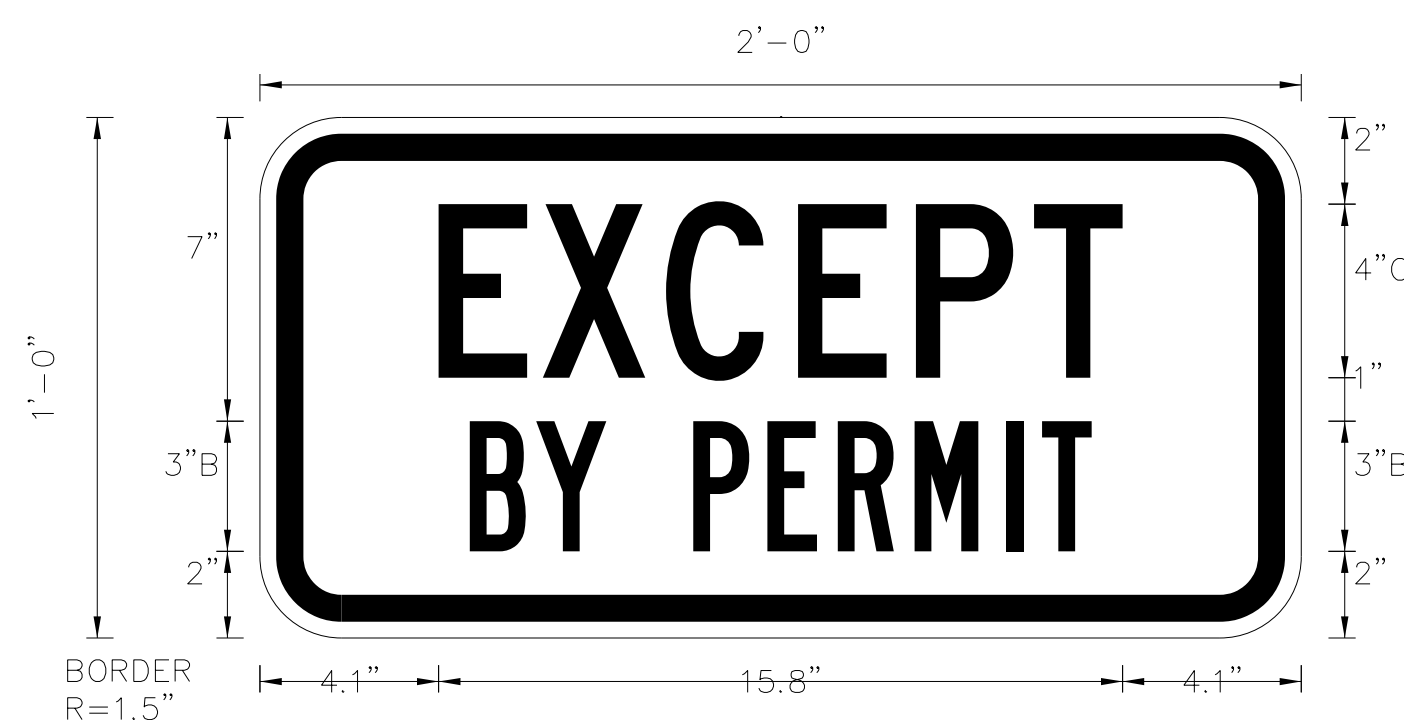
<p>SIGN NUMBER: 413 TYPE: E QUANTITY: 1</p> <p>SIGN WIDTH: 2'-0" HEIGHT: 1'-0" TOTAL AREA: 2.0 Sq.Ft.</p> <p>BORDER TYPE: FLUSH RECESS: 0.38" WIDTH: 0.63" RADII: 1.5"</p> <p>NO. Z BARS: LENGTH:</p>	<p>BACKG COLOR: White COPY COLOR: Black</p> <p>DESIGN BY: jgm PROJECT ID: W-5710AK</p> <p>CHECKED BY: LOCATION: Apr 28, 2022 DIV: 10</p>	 <p>BORDER R=1.5" TH=0.63" IN=0.38"</p> <p style="text-align: right;">Spacing Factor is 1 unless specified otherwise</p>																																																																															
<p>USE NOTES: 1,2</p> <ol style="list-style-type: none"> Legend and border(except those that are colored black) shall be direct applied Grade B sheeting. Background shall be Grade C reflective sheeting. Shields; A, B, and C type arrows shall be on 0.032" (0.8mm) aluminum and demountable. Bottom panel shall be yellow Grade C sheeting. Legend shall be direct applied black non-reflective sheeting. Yellow panel is: 																																																																																	
<p>LETTER POSITIONS</p> <p>Letter spacings are to start of next letter</p> <table border="1" style="width: 100%; border-collapse: collapse;"> <thead> <tr> <th></th> <th>E</th> <th>X</th> <th>C</th> <th>E</th> <th>P</th> <th>T</th> <th></th> <th></th> <th></th> <th></th> <th></th> <th></th> <th></th> <th></th> <th></th> <th></th> <th></th> <th></th> <th>Series/Size Text Length</th> </tr> </thead> <tbody> <tr> <td></td> <td>4.1</td> <td>2.4</td> <td>2.8</td> <td>3</td> <td>2.7</td> <td>2.7</td> <td>2</td> <td>4.1</td> <td></td> <td></td> <td></td> <td></td> <td></td> <td></td> <td></td> <td></td> <td></td> <td></td> <td>C 2000 15.8</td> </tr> <tr> <td></td> <td></td> <td>B</td> <td>Y</td> <td></td> <td>P</td> <td>E</td> <td>R</td> <td>M</td> <td>I</td> <td>T</td> <td></td> <td></td> <td></td> <td></td> <td></td> <td></td> <td></td> <td></td> <td>B 2000 14.3</td> </tr> <tr> <td></td> <td>4.8</td> <td>1.5</td> <td>1.6</td> <td>2</td> <td>1.7</td> <td>1.6</td> <td>1.8</td> <td>2.1</td> <td>0.8</td> <td>1.1</td> <td>4.8</td> <td></td> <td></td> <td></td> <td></td> <td></td> <td></td> <td></td> </tr> </tbody> </table> <p>FILENAME: W-5710AK_Signing_Existing</p> <p style="text-align: right;">NORTH CAROLINA D.O.T. SIGN DETAIL</p>				E	X	C	E	P	T													Series/Size Text Length		4.1	2.4	2.8	3	2.7	2.7	2	4.1											C 2000 15.8			B	Y		P	E	R	M	I	T									B 2000 14.3		4.8	1.5	1.6	2	1.7	1.6	1.8	2.1	0.8	1.1	4.8							
	E	X	C	E	P	T													Series/Size Text Length																																																														
	4.1	2.4	2.8	3	2.7	2.7	2	4.1											C 2000 15.8																																																														
		B	Y		P	E	R	M	I	T									B 2000 14.3																																																														
	4.8	1.5	1.6	2	1.7	1.6	1.8	2.1	0.8	1.1	4.8																																																																						

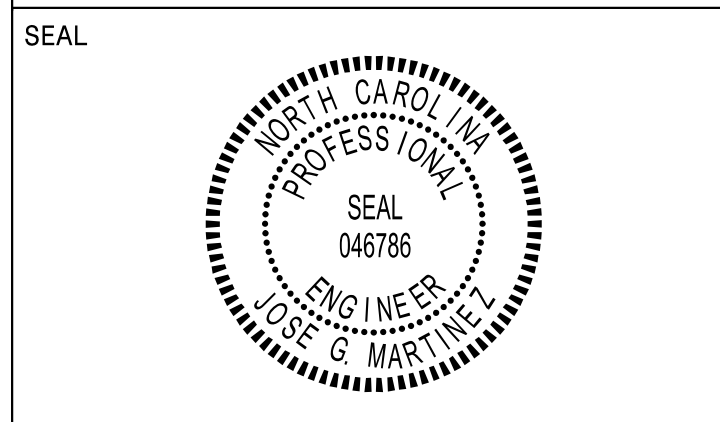

**DOCUMENT NOT CONSIDERED FINAL
UNLESS ALL SIGNATURES COMPLETED**

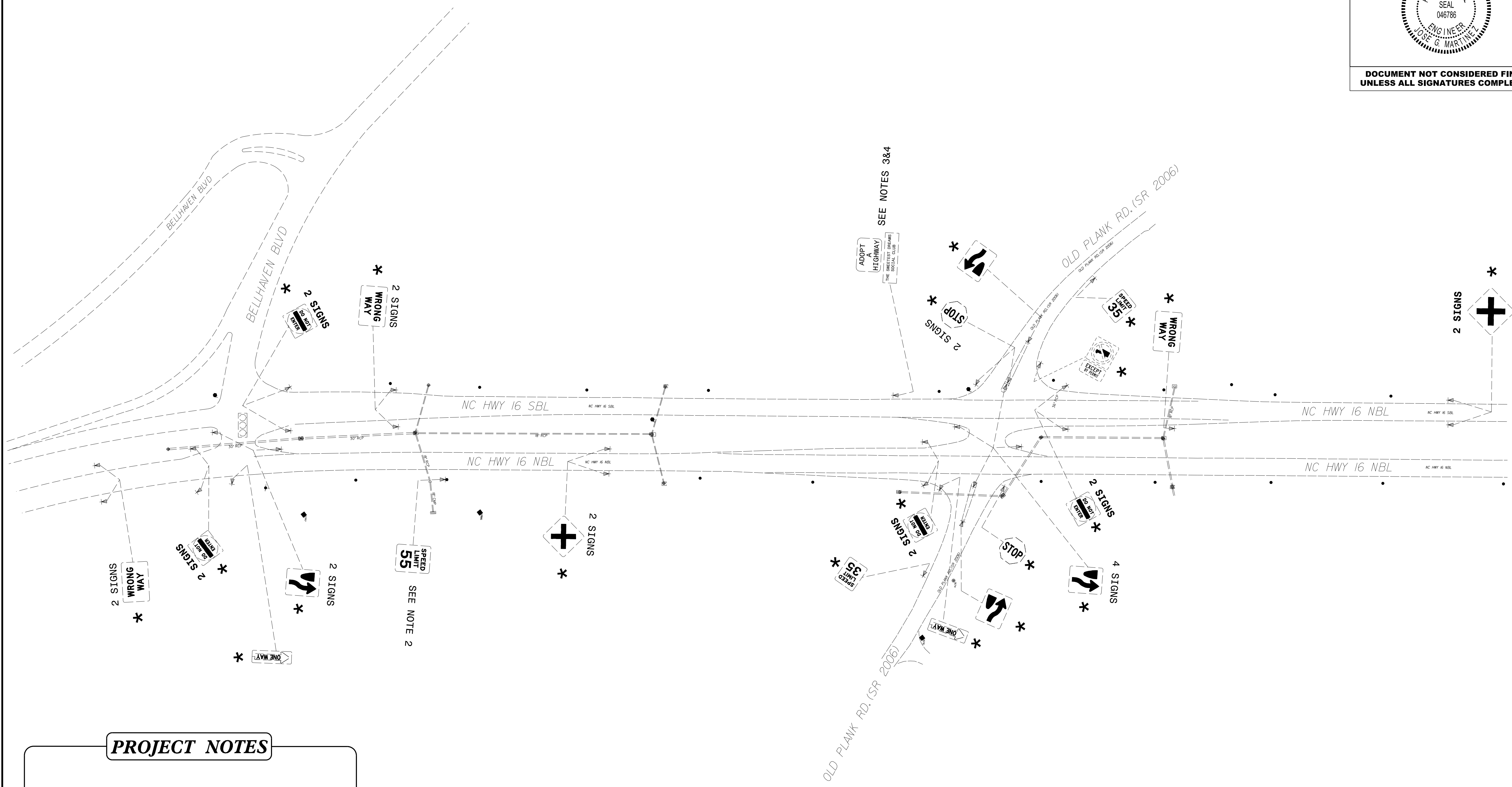
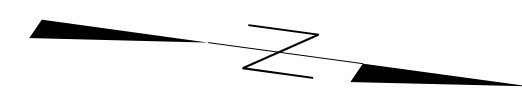

PROJECT NOTES

- 1 DISPOSAL OF SIGN SYSTEM, U-CHANNEL
- 2 DISPOSAL OF SIGN, D, E, OR F
- 3 RELOCATE SIGN, TYPE E
- 4 DISPOSAL OF SUPPORT, U-CHANNEL

* SEE NOTE 1

EXISTING SIGNS

04/29/22
 U:\Projects\2022 Sign Designs\Div 10\W-5710AK\W-5710AK_Signing_Existing.dgn
 Jose G. Martinez

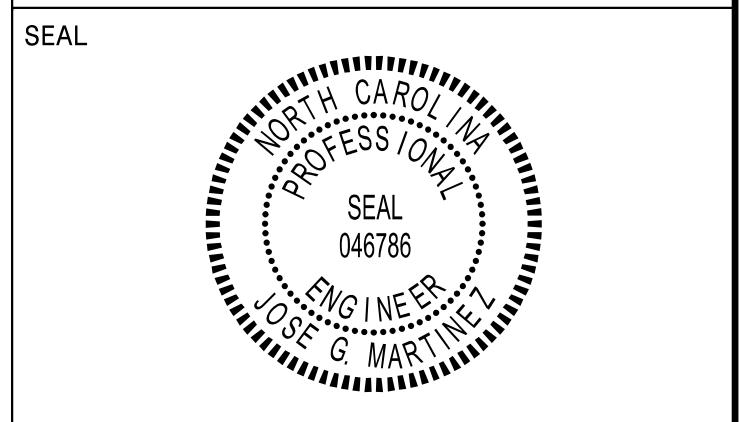

**DOCUMENT NOT CONSIDERED FINAL
UNLESS ALL SIGNATURES COMPLETED**

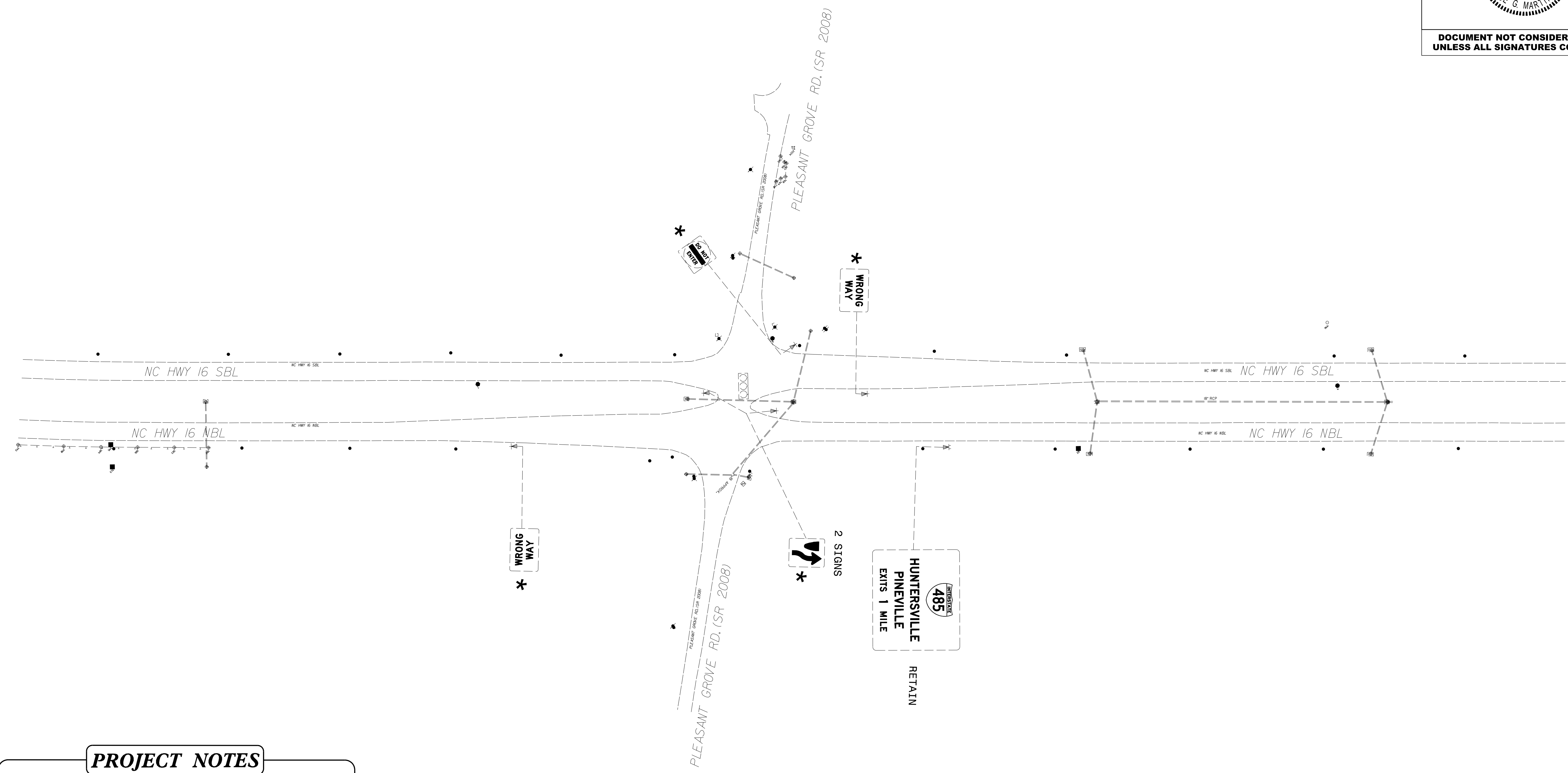
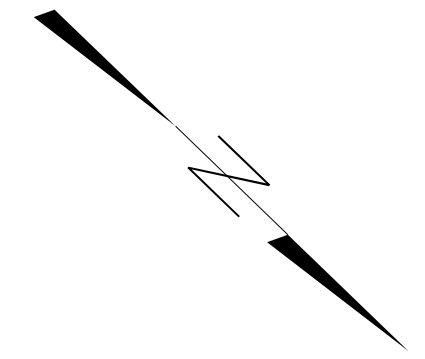

PROJECT NOTES

- 1 DISPOSAL OF SIGN SYSTEM, U-CHANNEL
- 2 DISPOSAL OF SIGN, D, E, OR F
- 3 RELOCATE SIGN, TYPE E
- 4 DISPOSAL OF SUPPORT, U-CHANNEL

* SEE NOTE 1

EXISTING SIGNS

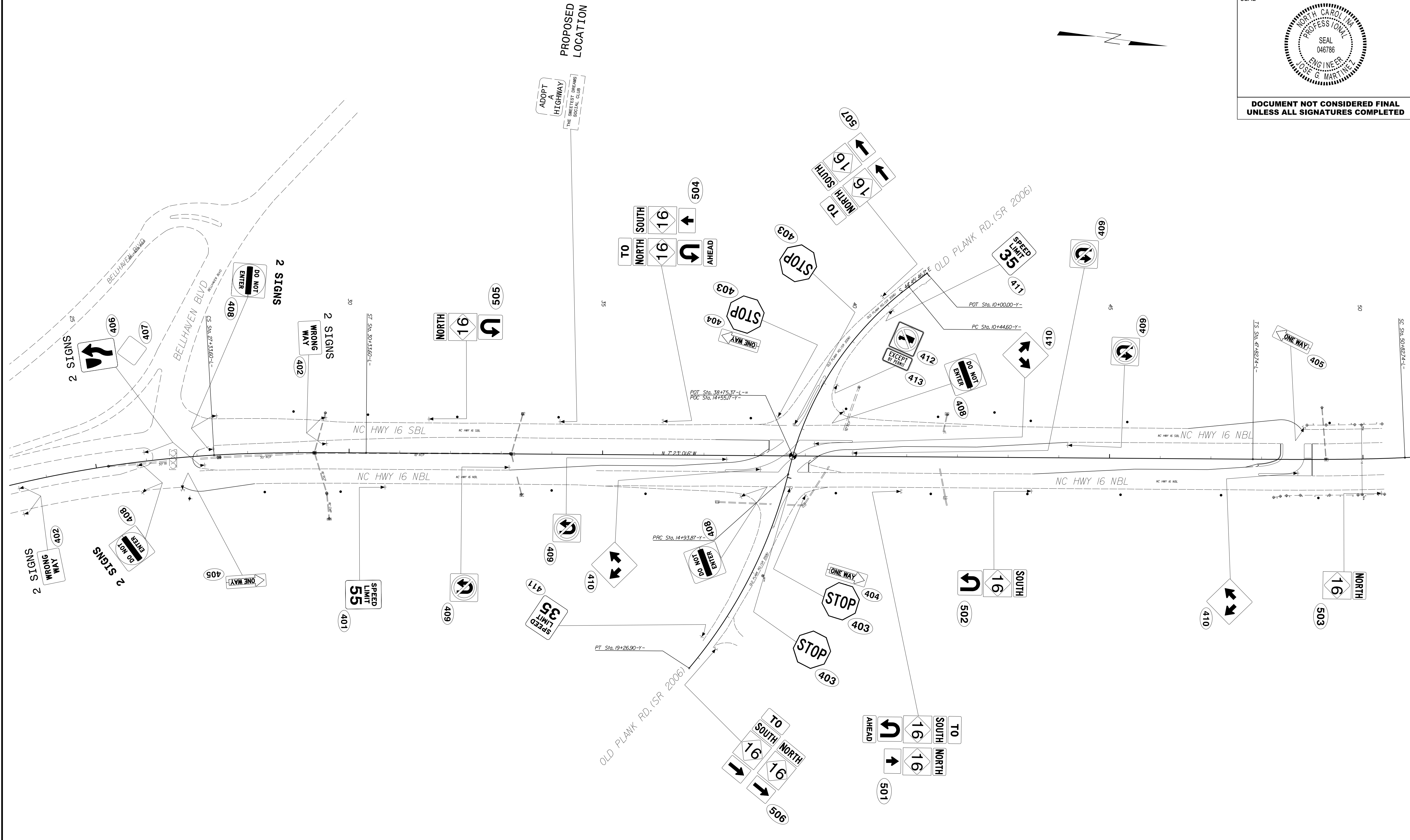
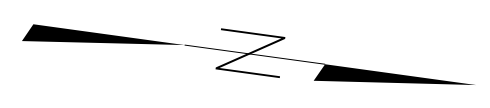

04/29/22
 U:\Projects\2022 Sign Designs\Div 10\W-5710AK\W-5710AK_Signing_Proposed.dgn
 User: jmartinez

PROPOSED SIGNS

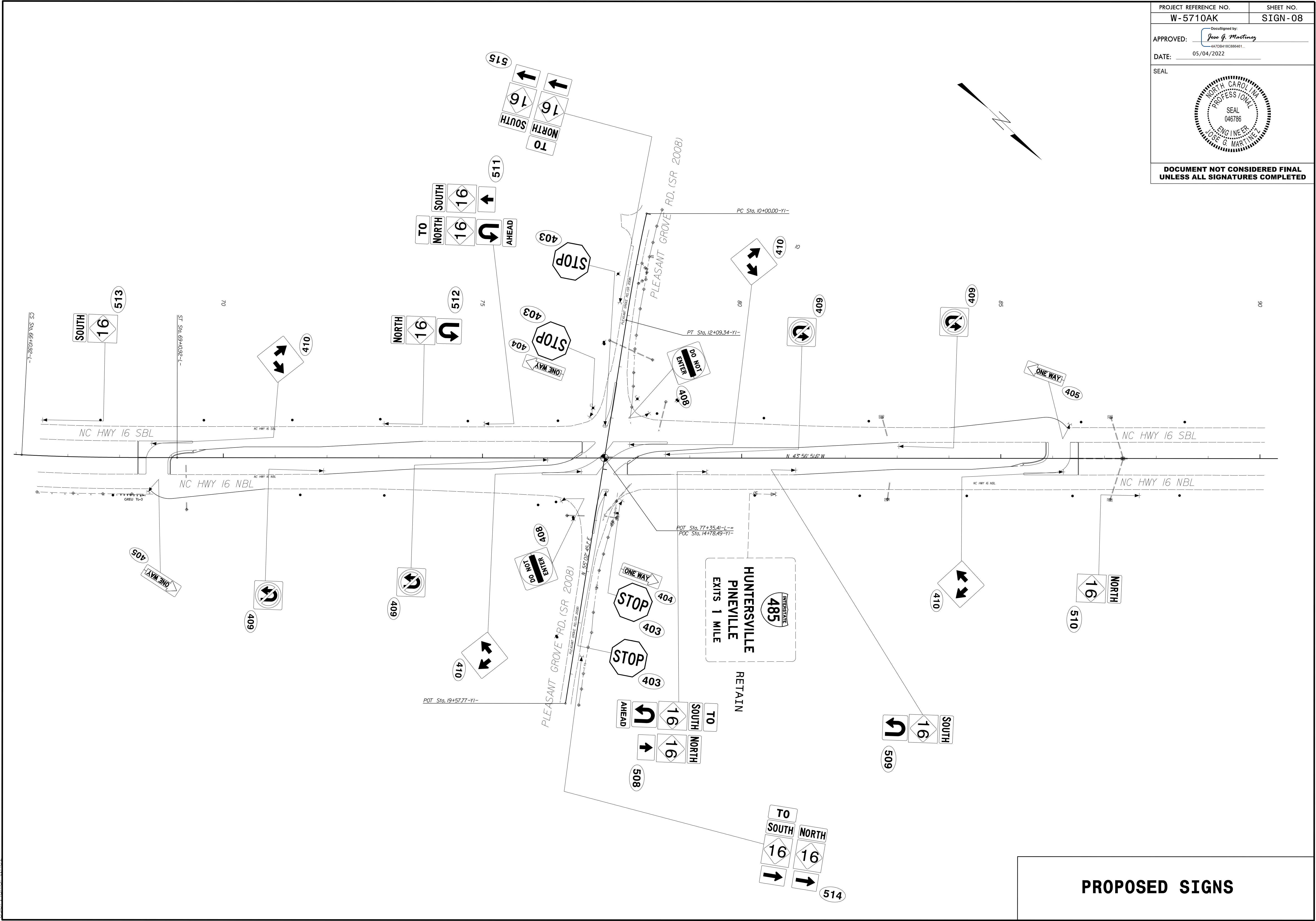

PROPOSED SIGNS

PROJECT NO.	SHEET NO.
44856.3.39	TCP-1
F.A. PROJECT NO. HSIP-00610651	

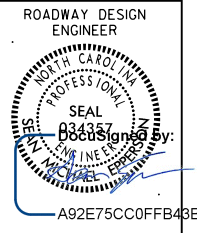

INSTALL ALL SIGNS PERTAINING TO HATCHED AREA DURING THIS PHASE SEE SHEETS SIGN-01 - SIGN-06

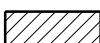
 Phase I of Construction

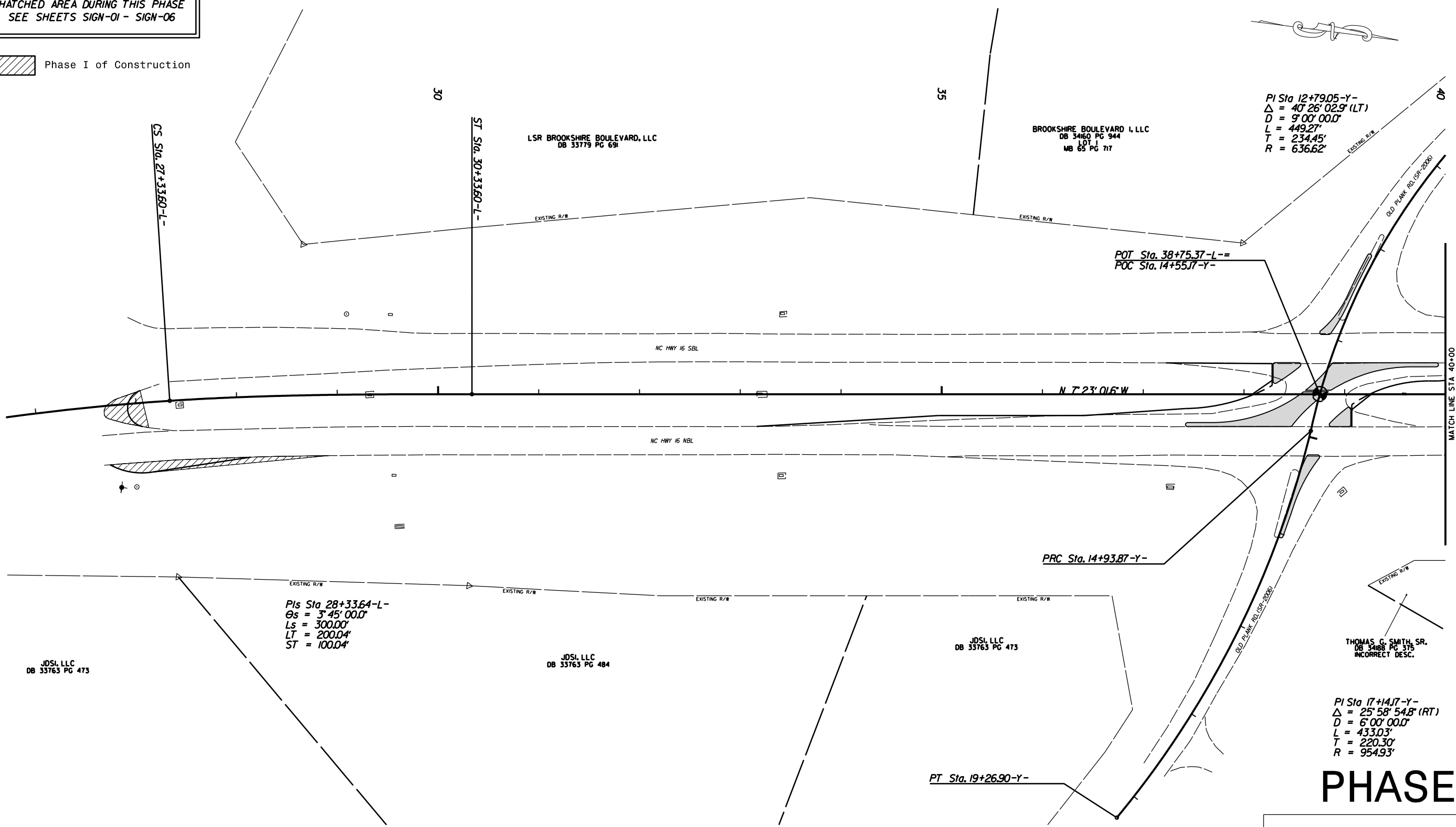

PHASE I

SIGNALIZED RCI ON NC 16 AT OLD PLANK RD.(SR-2006) AND PLEASANT GROVE RD.(SR-2008)

SCALE	1"=50'		REVISIONS
DATE	3-2022		
DWG. BY	TBL		
DESIGN BY	TBL		
APPROVED	JDH		

MATCH LINE STA 40+00 SEE SHEET TCP-2

PROJECT NO.	SHEET NO.
44856.3.39	TCP-2
F.A. PROJECT NO. HSIP-00610651	

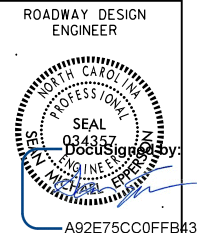

INSTALL ALL SIGNS PERTAINING TO HATCHED AREA DURING THIS PHASE SEE SHEETS SIGN-01 - SIGN-06

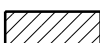
 Phase I of Construction

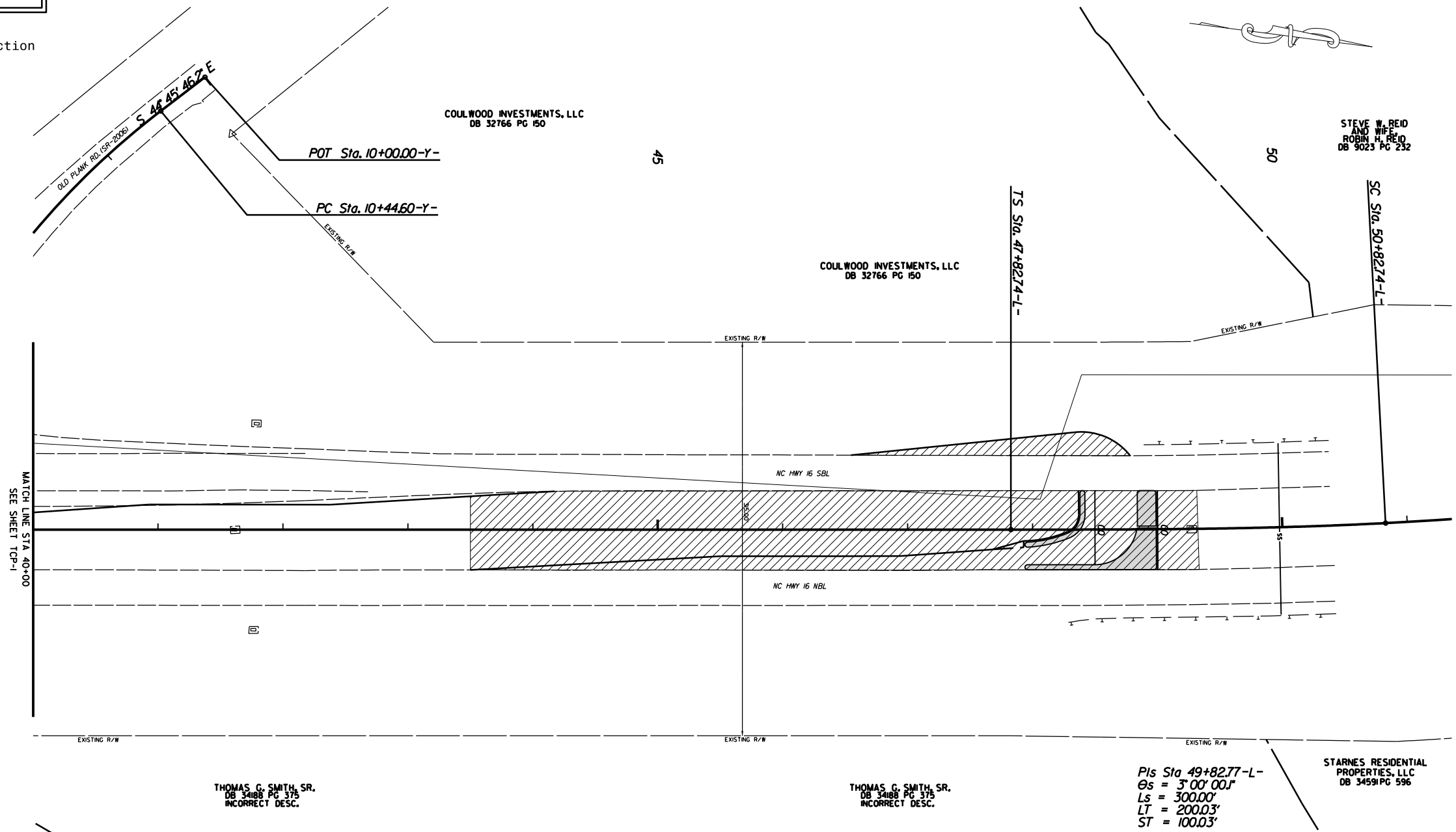

PHASE I

SIGNALIZED RCI ON NC 16 AT OLD PLANK RD.(SR-2006) AND PLEASANT GROVE RD.(SR-2008)

SCALE	1"=50'		REVISIONS
DATE	3-2022		
DWG. BY	TBL		
DESIGN BY	TBL		
APPROVED	JDH		

PROJECT NO.	SHEET NO.
44856.3.39	TCP-3
F.A. PROJECT NO. HSIP-00610651	

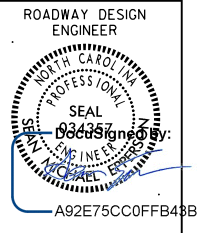

INSTALL ALL SIGNS PERTAINING TO HATCHED AREA DURING THIS PHASE SEE SHEETS SIGN-01 - SIGN-06

Phase II of Construction

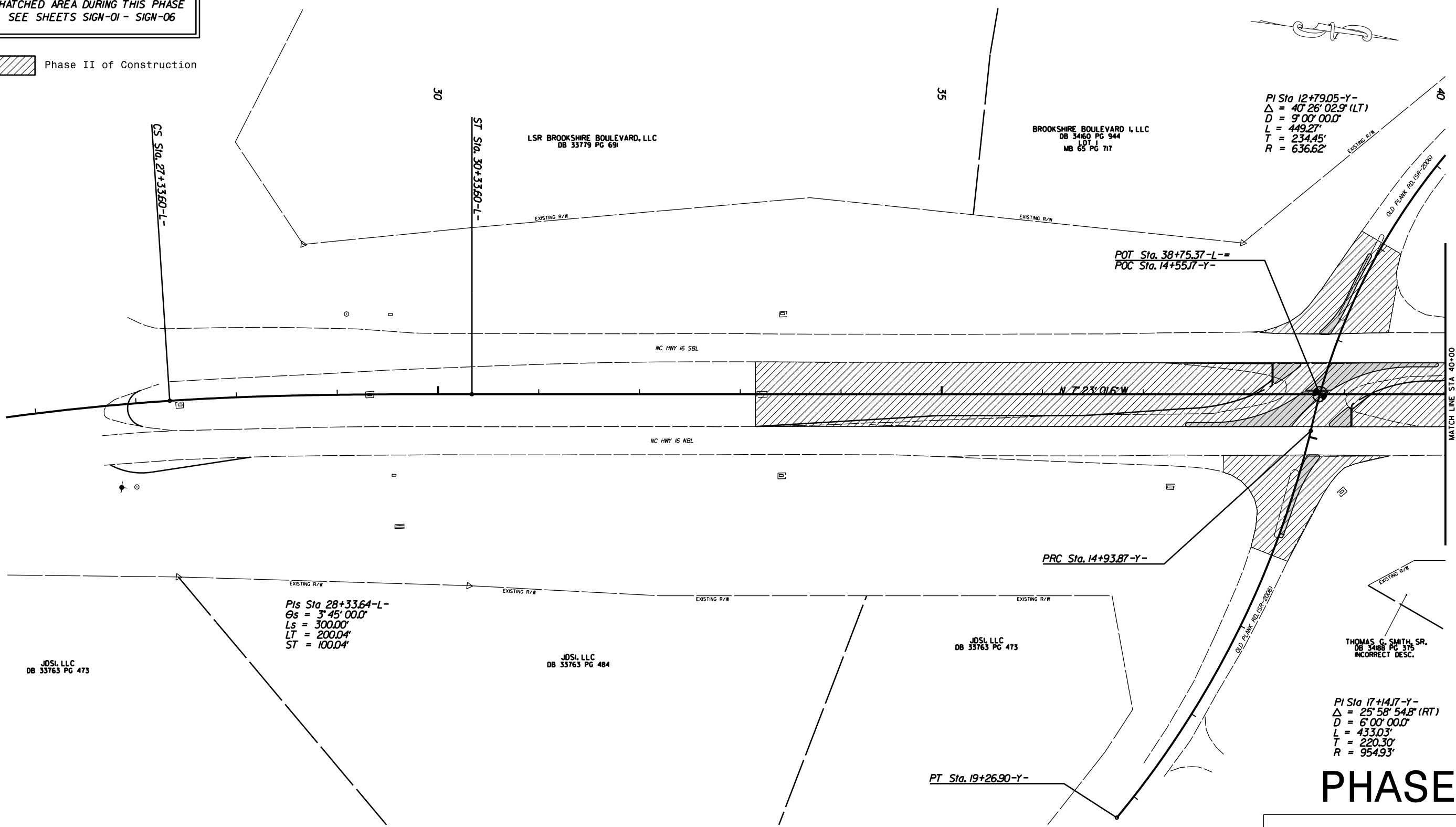

MATCH LINE STA. 40+00
SEE SHEET TCP-4

PHASE II

SIGNALIZED RCI ON NC 16
AT OLD PLANK RD.(SR-2006) AND
PLEASANT GROVE RD.(SR-2008)

SCALE	1"=50'		REVISIONS
DATE	3-2022		
DWG. BY	TBL		
DESIGN BY	TBL		
APPROVED	JDH		

PROJECT NO.	SHEET NO.
44856.3.39	TCP-4
F.A. PROJECT NO. HSIP-00610651	

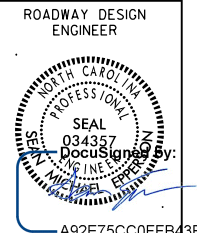

INSTALL ALL SIGNS PERTAINING TO HATCHED AREA DURING THIS PHASE SEE SHEETS SIGN-01 - SIGN-06

 Phase II of Construction

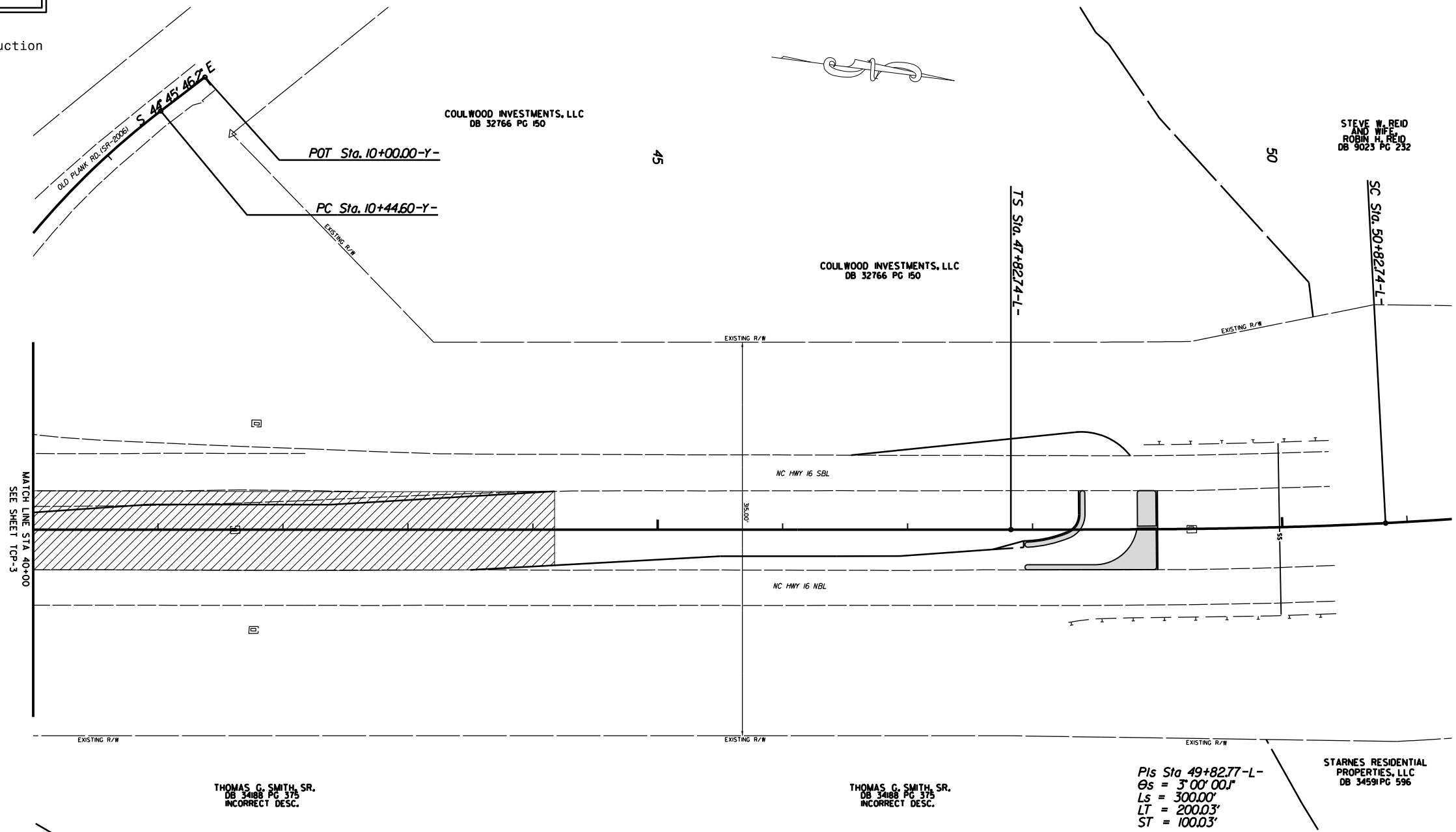

PHASE II

SIGNALIZED RCI ON NC 16 AT OLD PLANK RD.(SR-2006) AND PLEASANT GROVE RD.(SR-2008)

SCALE	1"=50'		REVISIONS
DATE	3-2022		
DWG. BY	TBL		
DESIGN BY	TBL		
APPROVED	JDH		

PROJECT NO.	SHEET NO.
44856.3.39	TCP-5
F.A. PROJECT NO. HSIP-00610651	

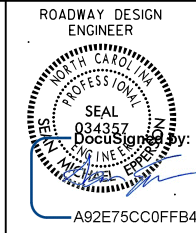

INSTALL ALL SIGNS PERTAINING TO HATCHED AREA DURING THIS PHASE SEE SHEETS SIGN-01 - SIGN-06

 Phase III of Construction

PI Sta 11+04.70-YI-
 $\Delta = 3^\circ 22' 43.2''$ (LT)
 $D = 136' 50.3''$
 $L = 209.34'$
 $T = 104.70'$
 $R = 3550.00'$

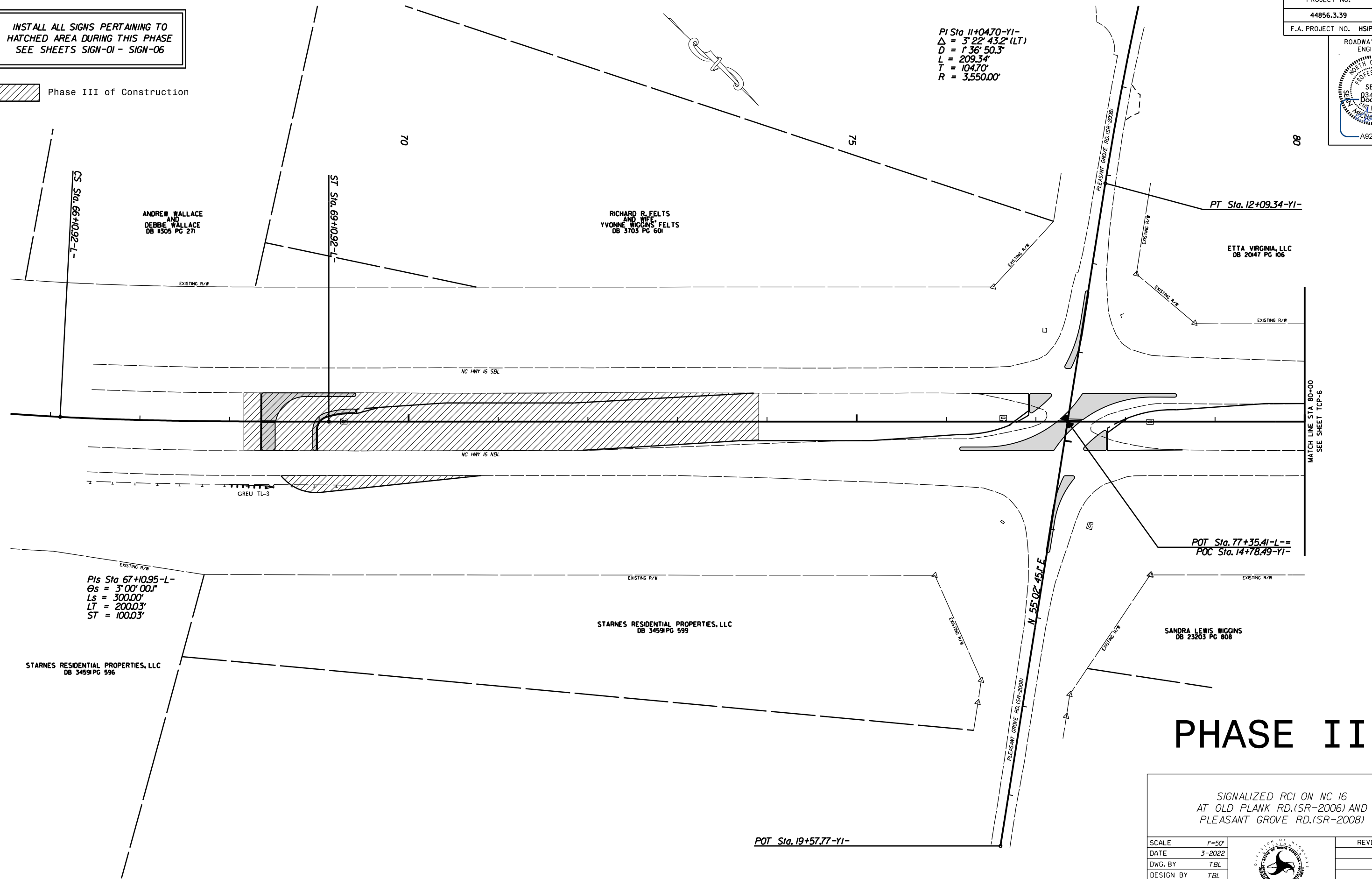

PHASE III

SIGNALIZED RCI ON NC 16 AT OLD PLANK RD.(SR-2006) AND PLEASANT GROVE RD.(SR-2008)	
SCALE	1"=50'
DATE	3-2022
DWG. BY	TBL
DESIGN BY	TBL
APPROVED	JDH
REVISIONS	



MATCH LINE STA 80+00 SEE SHEET TCP-6

08

POT Sta. 19+57.77-YI-

STARNES RESIDENTIAL PROPERTIES, LLC
DB 34591 PG 596

PIs Sta 67+10.95-L-
 $\theta_s = 3^\circ 00' 00''$
 $L_s = 300.00'$
 $LT = 200.03'$
 $ST = 100.03'$

ANDREW WALLACE AND DEBBIE WALLACE
DB #305 PG 271

RICHARD R. FELTS AND WIFE YVONNE WIGGINS' FELTS
DB 3703 PG 601

ETTA VIRGINIA, LLC
DB 20417 PG 106

SANDRA LEWIS WIGGINS
DB 23203 PG 808

STARNES RESIDENTIAL PROPERTIES, LLC
DB 34591 PG 599

EXISTING R/W

NC HWY 16 SBL

NC HWY 16 NBL

GREU TL-3

EXISTING R/W

EXISTING R/W

EXISTING R/W

EXISTING R/W

EXISTING R/W

EXISTING R/W

EXISTING R/W

EXISTING R/W

N 55°02'45"E

PLEASANT GROVE RD.(SR-2008)

PLEASANT GROVE RD.(SR-2008)

PT Sta. 12+09.34-YI-

POT Sta. 77+35.41-L-=
POC Sta. 14+78.49-YI-

CS Sta. 66+10.92-L-

ST Sta. 69+10.92-L-

INSTALL ALL SIGNS PERTAINING TO
HATCHED AREA DURING THIS PHASE
SEE SHEETS SIGN-01 - SIGN-06

 Phase III of Construction

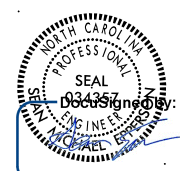
PROJECT NO.	SHEET NO.
44856.3.39	TCP-6
F.A. PROJECT NO. HSIP-001610651	
ROADWAY DESIGN ENGINEER	
	
A92E75CC0FFB43E...	

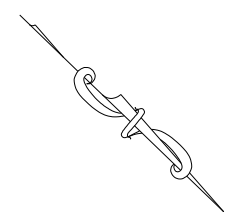
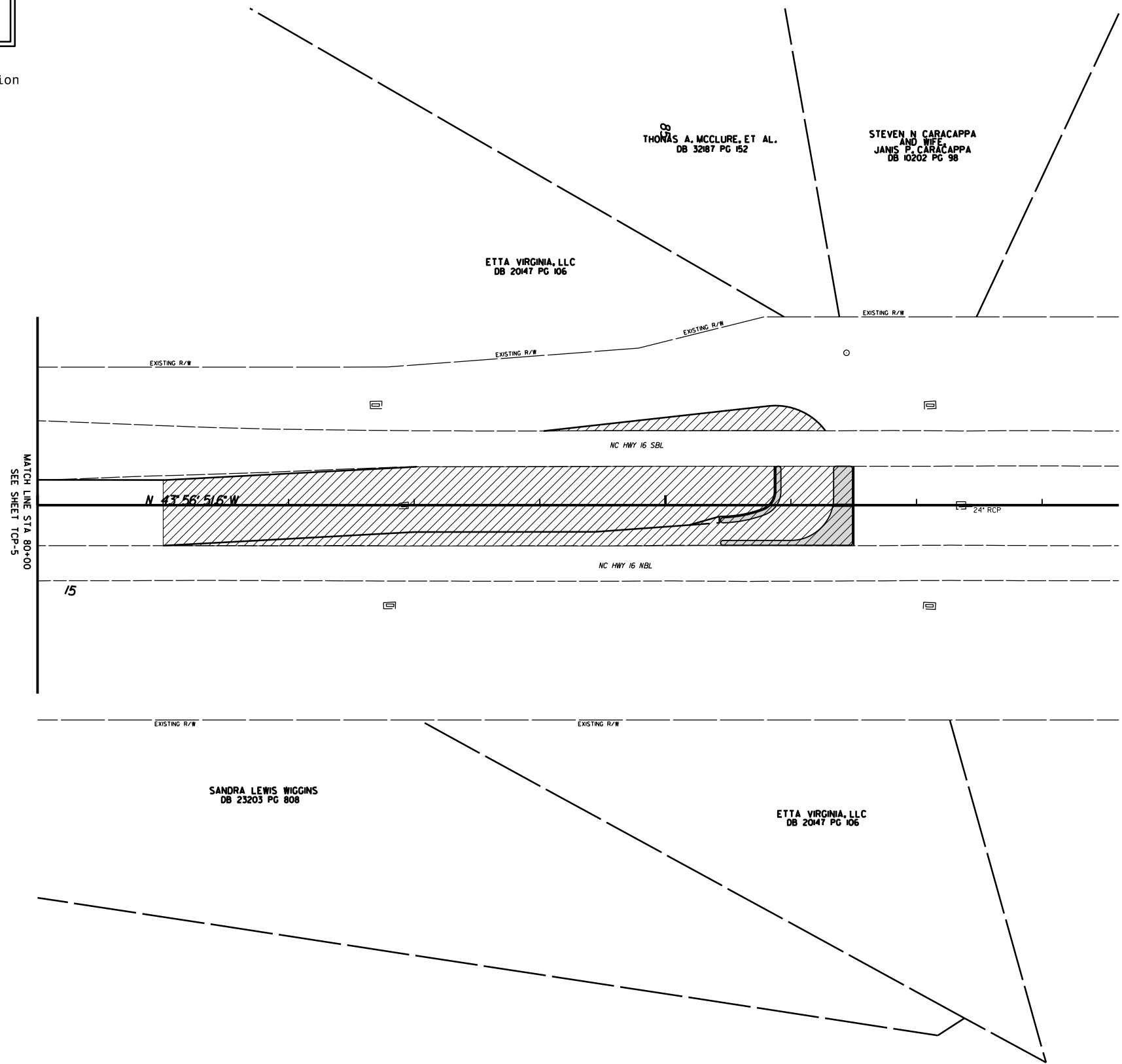

PHASE III

SIGNALIZED RCI ON NC 16
AT OLD PLANK RD.(SR-2006) AND
PLEASANT GROVE RD.(SR-2008)

SCALE	1"=50'		REVISIONS
DATE	3-2022		
DWG. BY	TBL		
DESIGN BY	TBL		
APPROVED	JDH		

PROJECT NO.	SHEET NO.
44856.3.39	TCP-7
F.A. PROJECT NO. HSIP-00610651	

ROADWAY DESIGN ENGINEER

SEAL

034387

DocuSign

A92E75CC0FFB48B

INSTALL ALL SIGNS PERTAINING TO HATCHED AREA DURING THIS PHASE SEE SHEETS SIGN-01 - SIGN-06

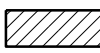
 Phase IV of Construction

PI Sta 11+04.70-YI-
 $\Delta = 3^{\circ} 22' 43.2"$ (LT)
 $D = 136' 50.3"$
 $L = 209.34'$
 $T = 104.70'$
 $R = 3550.00'$

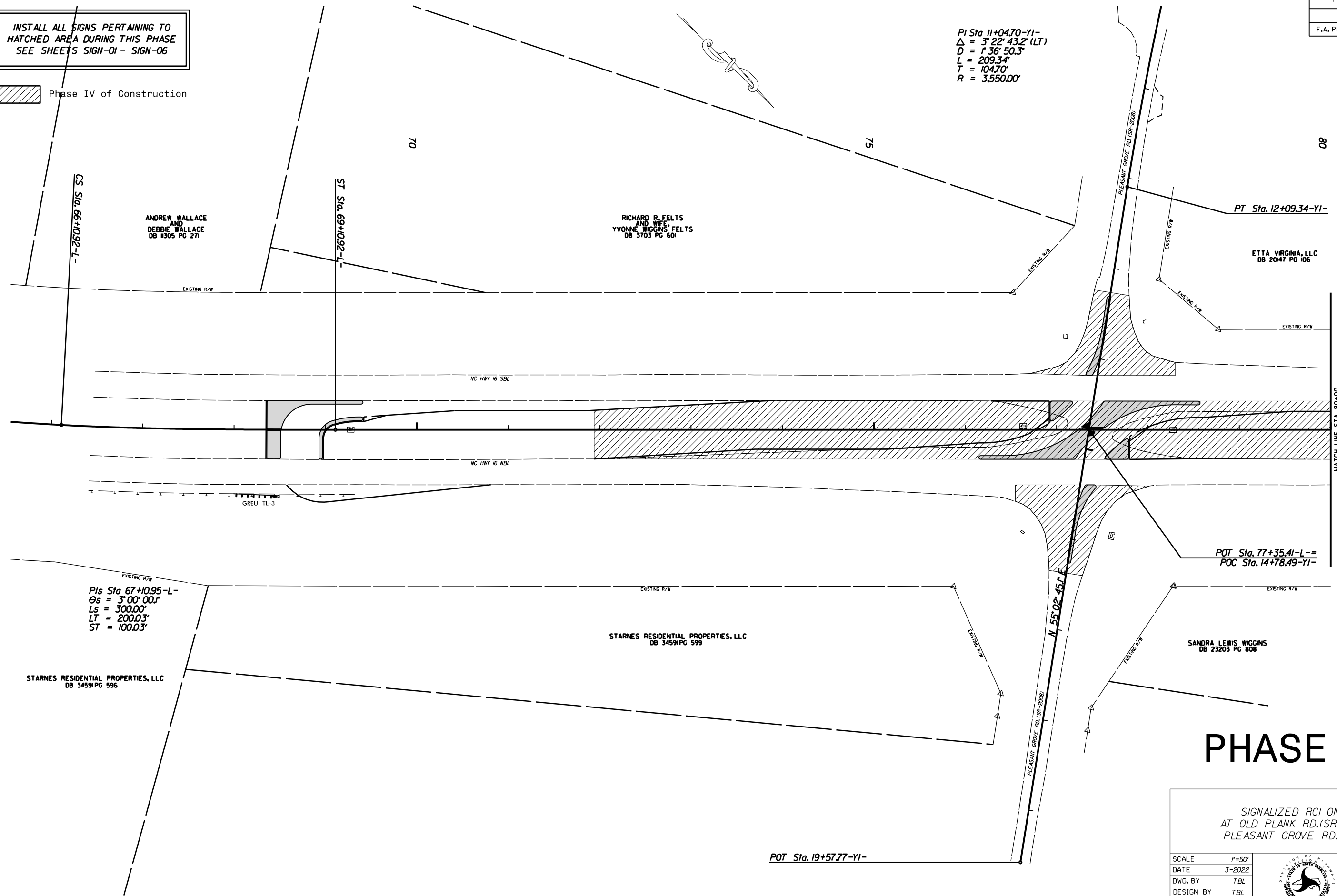

MATCH LINE STA 80+00
SEE SHEET TCP-8

PHASE IV

SIGNALIZED RCI ON NC 16
 AT OLD PLANK RD.(SR-2006) AND
 PLEASANT GROVE RD.(SR-2008)

SCALE	1"=50'		REVISIONS
DATE	3-2022		
DWG. BY	TBL		
DESIGN BY	TBL		
APPROVED	JDH		

INSTALL ALL SIGNS PERTAINING TO
HATCHED AREA DURING THIS PHASE
SEE SHEETS SIGN-01 - SIGN-06

 Phase IV of Construction

PROJECT NO.	SHEET NO.
44856.3.39	TCP-8
F.A. PROJECT NO. HSIP-00610651	

ROADWAY DESIGN
ENGINEER

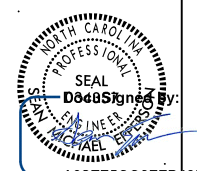

SEAL
004857
MICHAEL E. ...
A92E75CC0FFB43...

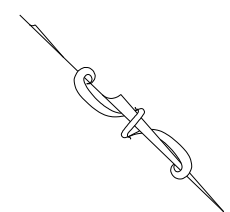
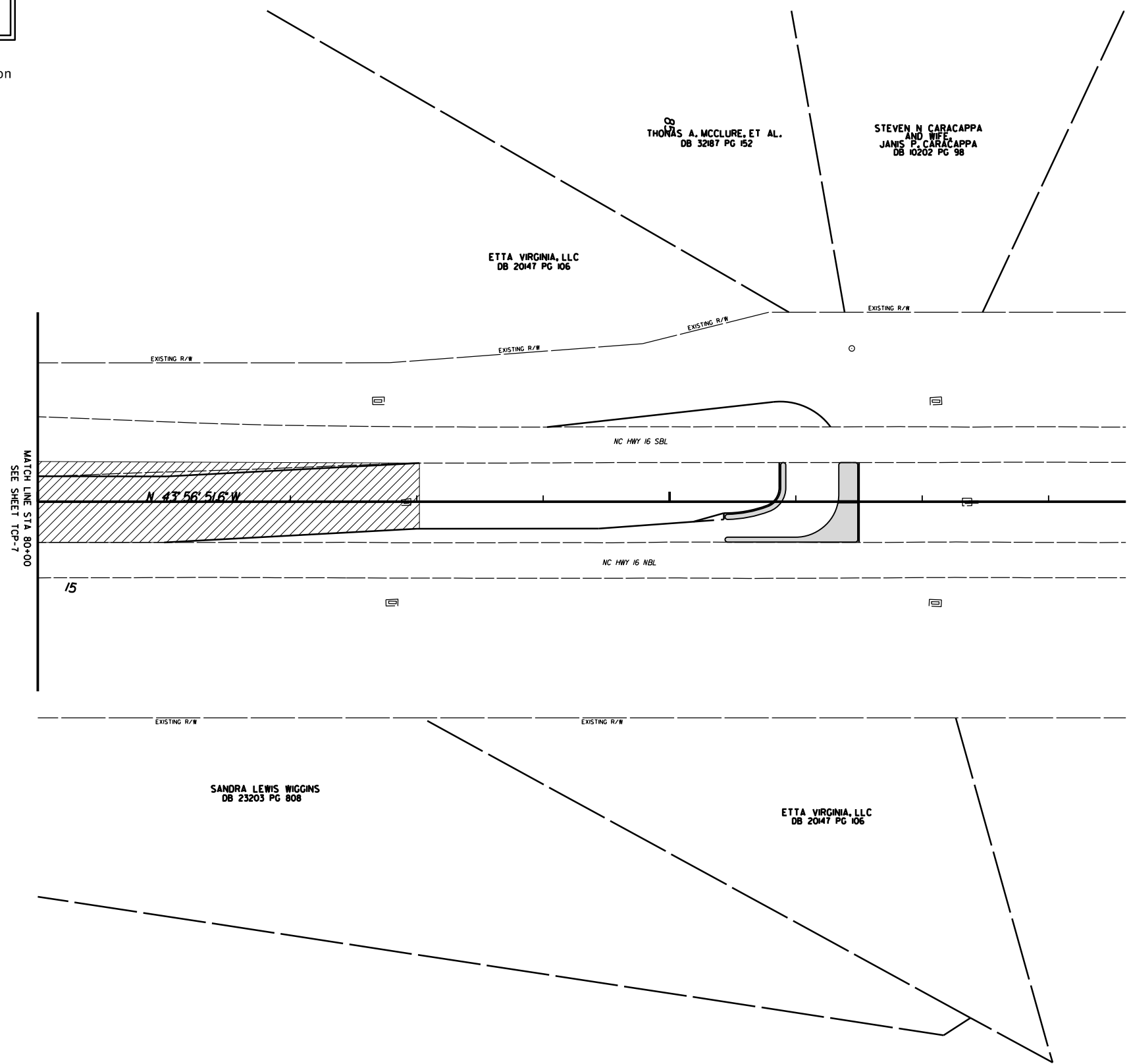

PHASE IV

SIGNALIZED RCI ON NC 16
AT OLD PLANK RD.(SR-2006) AND
PLEASANT GROVE RD.(SR-2008)

SCALE	1"=50'		REVISIONS
DATE	3-2022		
DWG. BY	TBL		
DESIGN BY	TBL		
APPROVED	JDH		



55 50 45 40 35 30 25 20 15 10 5 0 5 10 15 20 25 30 35 40 45 50 55 60 65 70 75 80 85 90 95

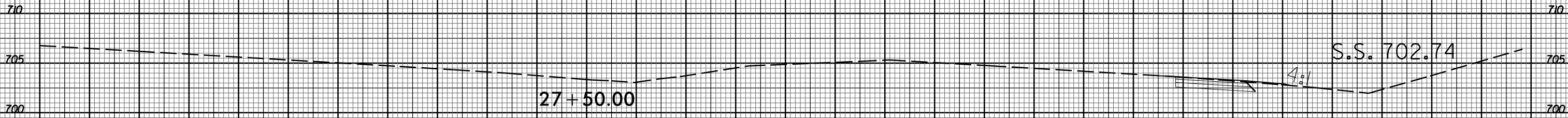
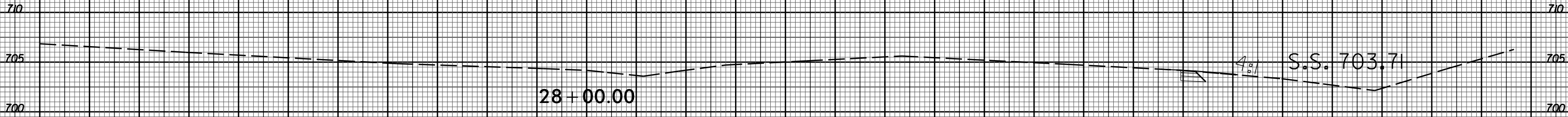
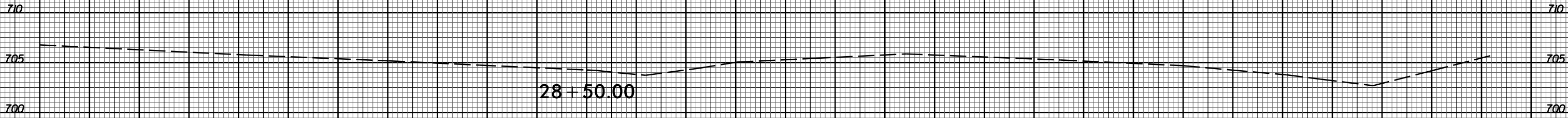

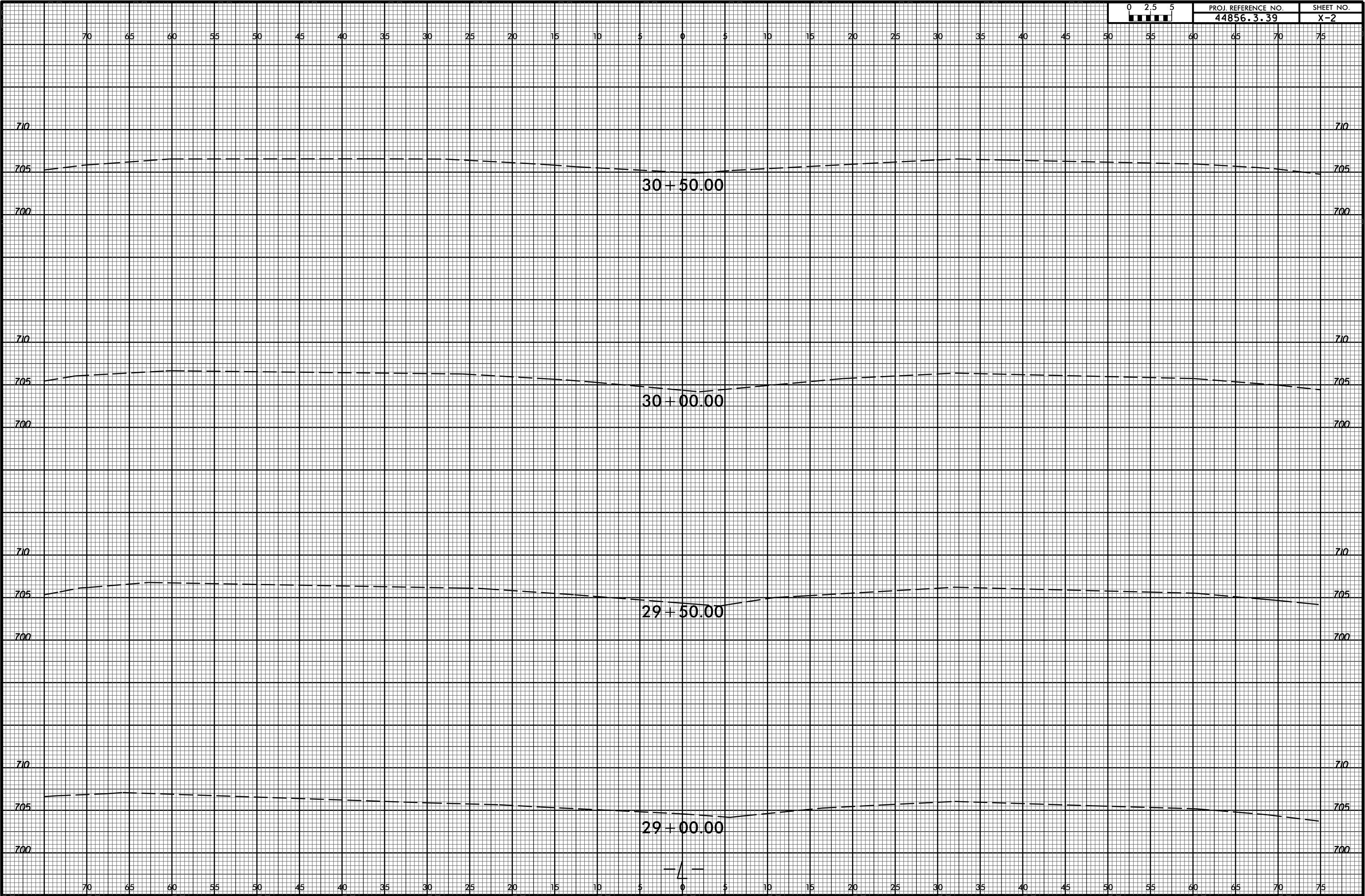



70 65 60 55 50 45 40 35 30 25 20 15 10 5 0 5 10 15 20 25 30 35 40 45 50 55 60 65 70 75

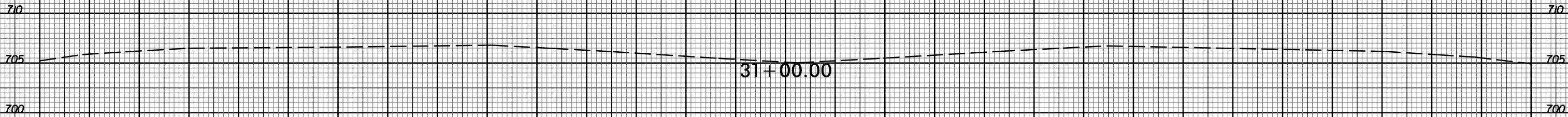
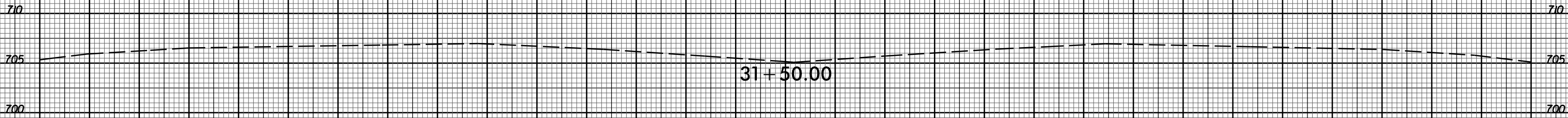
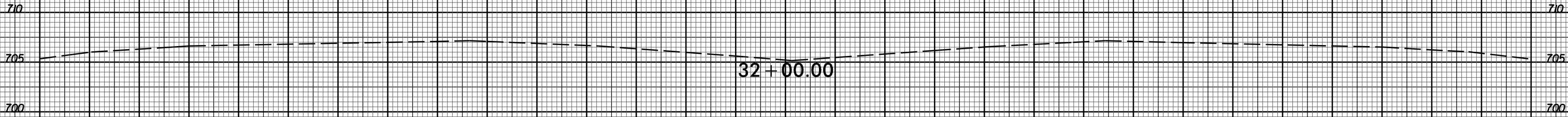
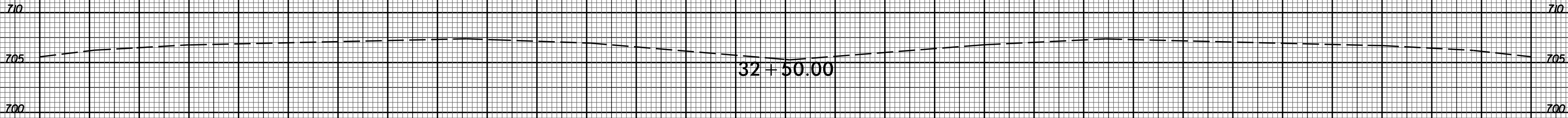

— 1 —



70 65 60 55 50 45 40 35 30 25 20 15 10 5 0 5 10 15 20 25 30 35 40 45 50 55 60 65 70 75

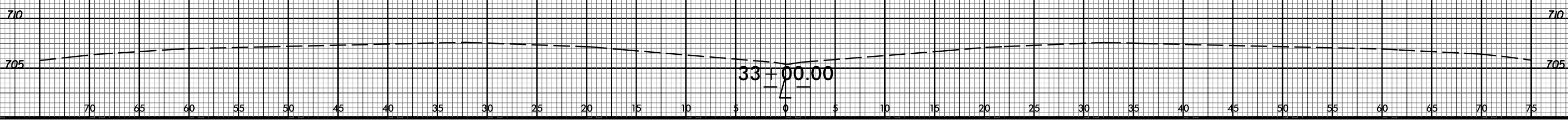
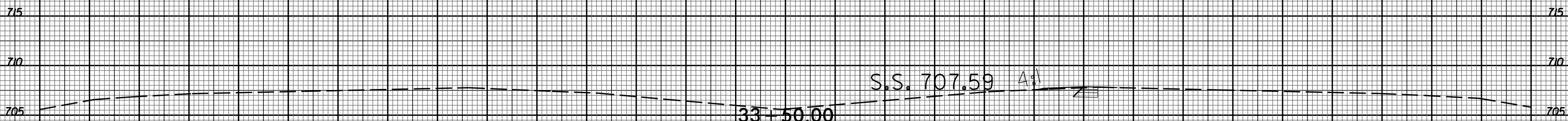
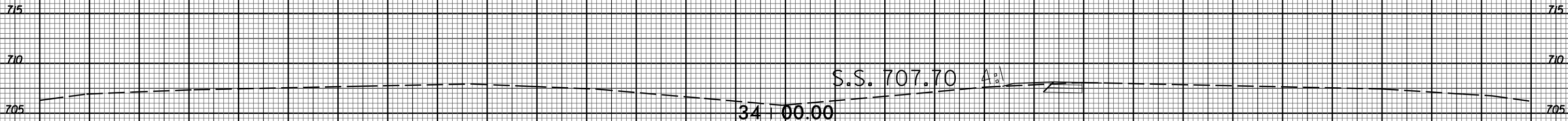
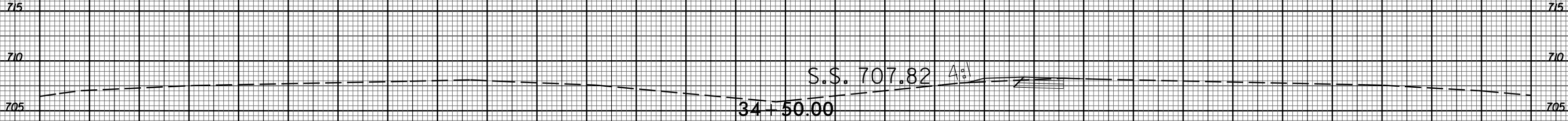

70 65 60 55 50 45 40 35 30 25 20 15 10 5 0 5 10 15 20 25 30 35 40 45 50 55 60 65 70 75

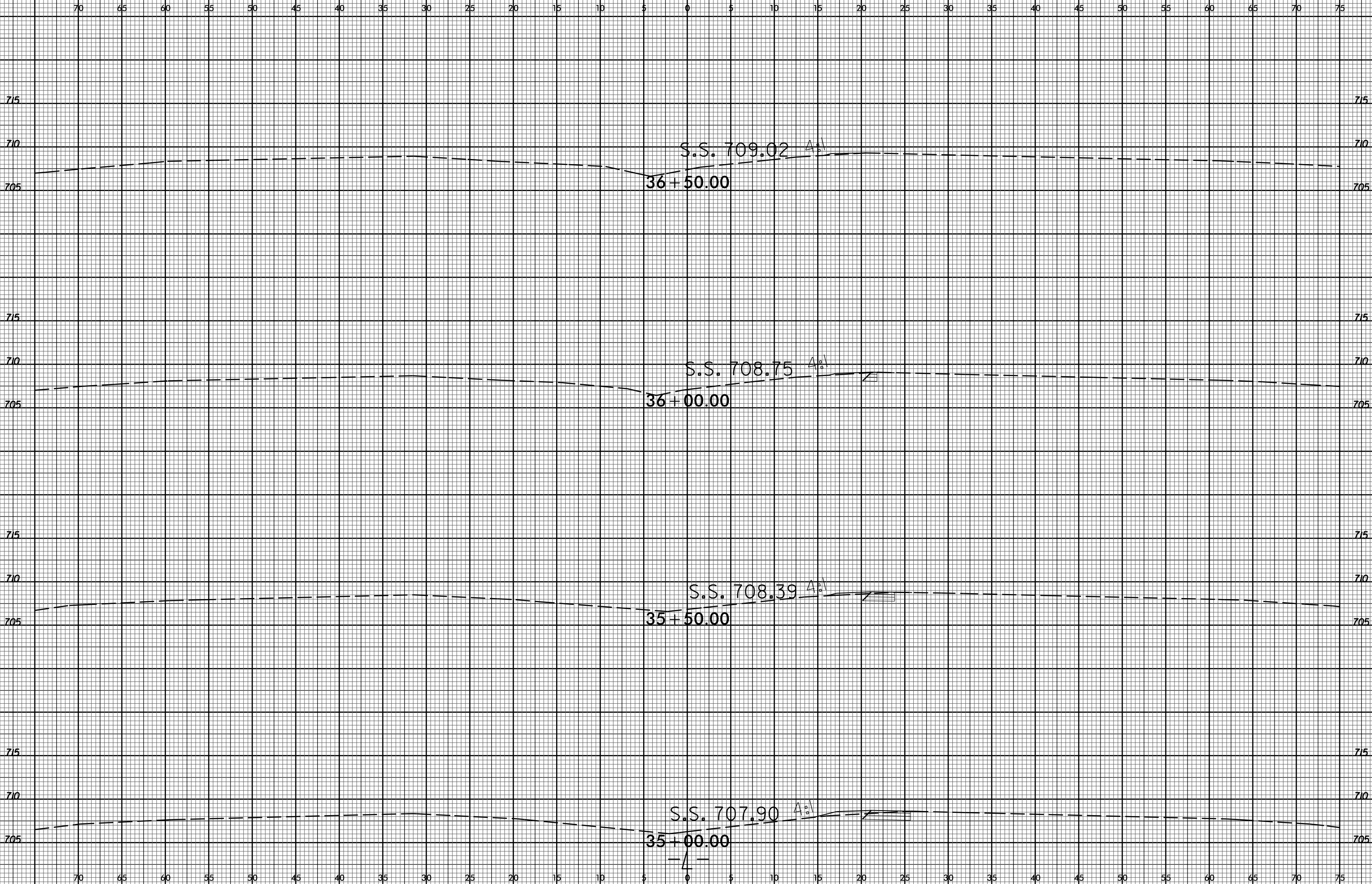



70 65 60 55 50 45 40 35 30 25 20 15 10 5 0 5 10 15 20 25 30 35 40 45 50 55 60 65 70 75

715 715

710 710

705 705

38+50.00

715 715

710 710

705 705

S.S. 708.19

38+00.00

715 715

710 710

705 705

S.S. 708.88

37+50.00

715 715

710 710

705 705

S.S. 709.05

37+00.00

— / —



70 65 60 55 50 45 40 35 30 25 20 15 10 5 0 5 10 15 20 25 30 35 40 45 50 55 60 65 70 75

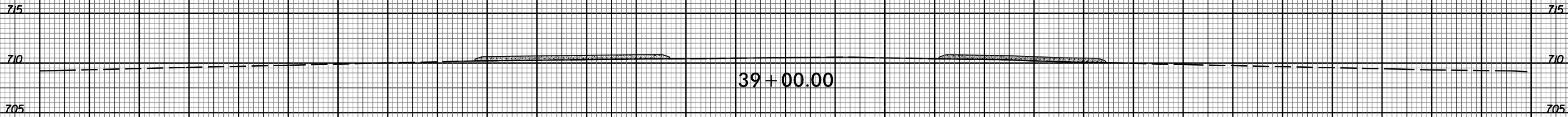
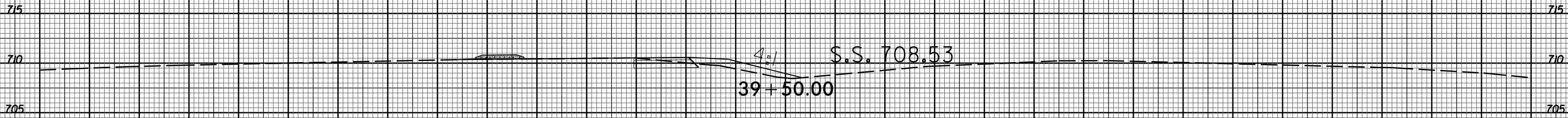
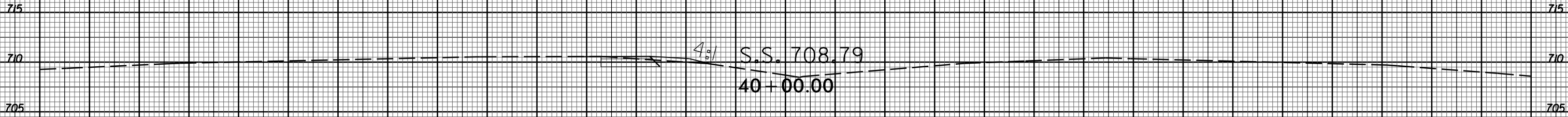
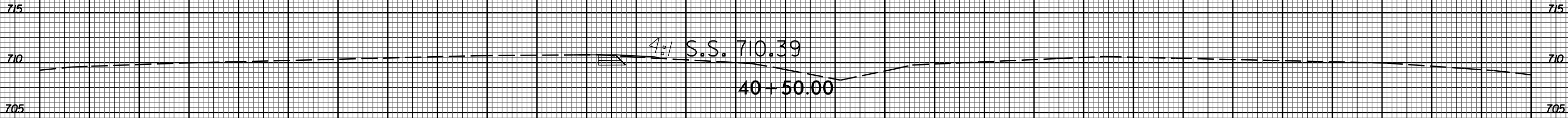

70 65 60 55 50 45 40 35 30 25 20 15 10 5 0 5 10 15 20 25 30 35 40 45 50 55 60 65 70 75



70 65 60 55 50 45 40 35 30 25 20 15 10 5 0 5 10 15 20 25 30 35 40 45 50 55 60 65 70 75

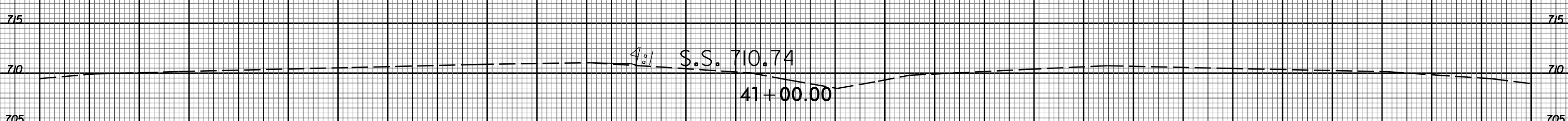
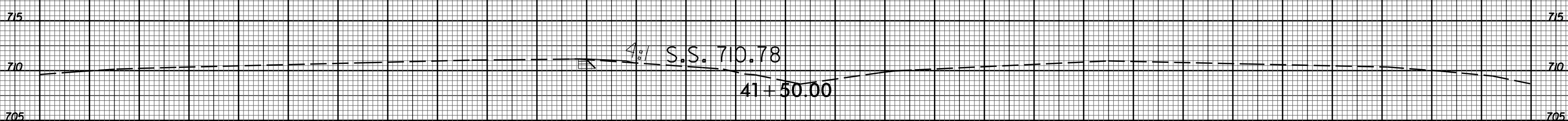
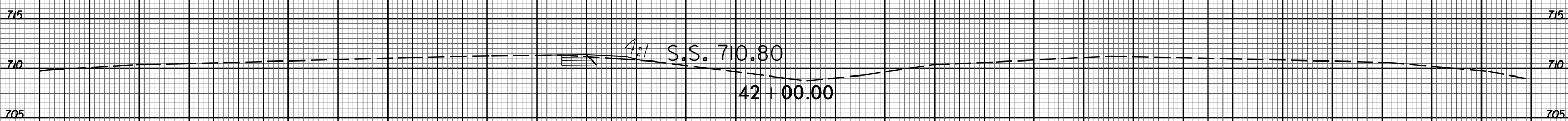
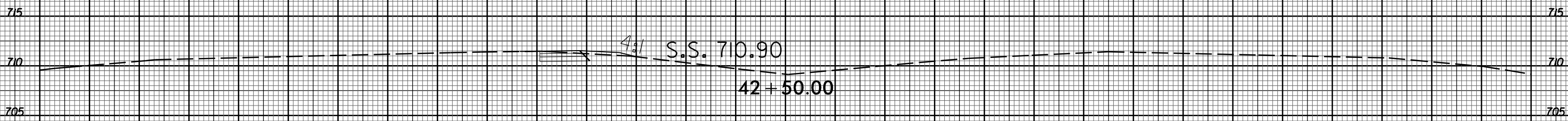

70 65 60 55 50 45 40 35 30 25 20 15 10 5 0 5 10 15 20 25 30 35 40 45 50 55 60 65 70 75



70 65 60 55 50 45 40 35 30 25 20 15 10 5 0 5 10 15 20 25 30 35 40 45 50 55 60 65 70 75

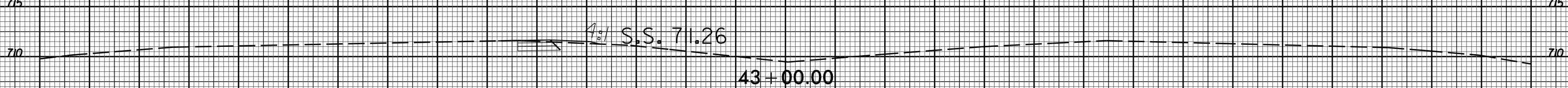
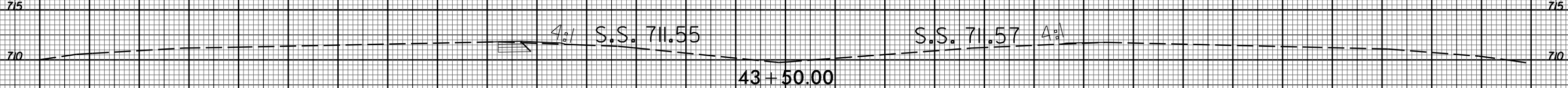
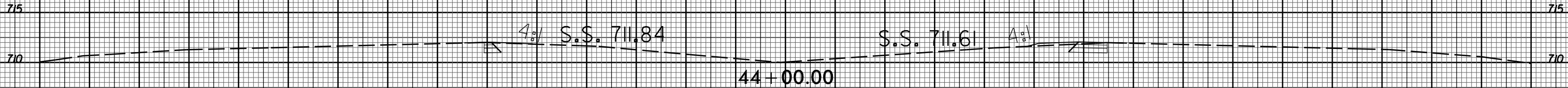
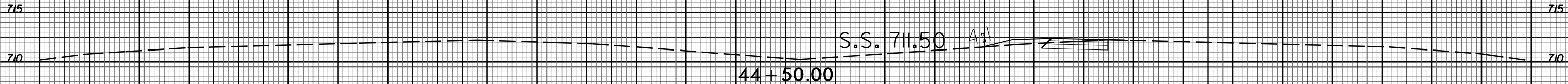

70 65 60 55 50 45 40 35 30 25 20 15 10 5 0 5 10 15 20 25 30 35 40 45 50 55 60 65 70 75



70 65 60 55 50 45 40 35 30 25 20 15 10 5 0 5 10 15 20 25 30 35 40 45 50 55 60 65 70 75

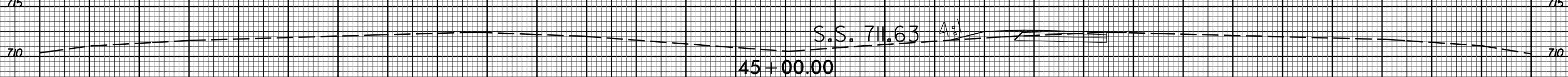
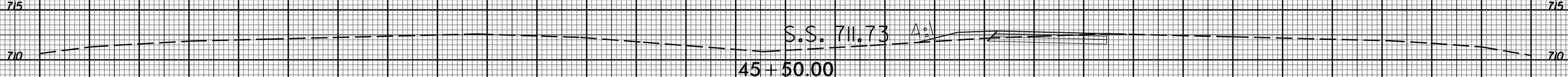
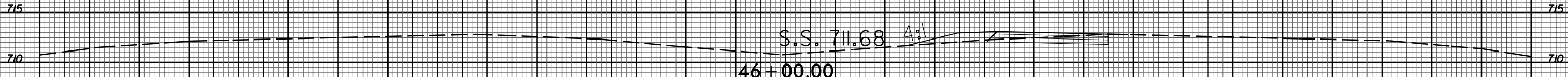
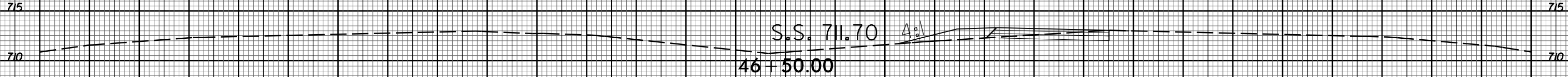

70 65 60 55 50 45 40 35 30 25 20 15 10 5 0 5 10 15 20 25 30 35 40 45 50 55 60 65 70 75

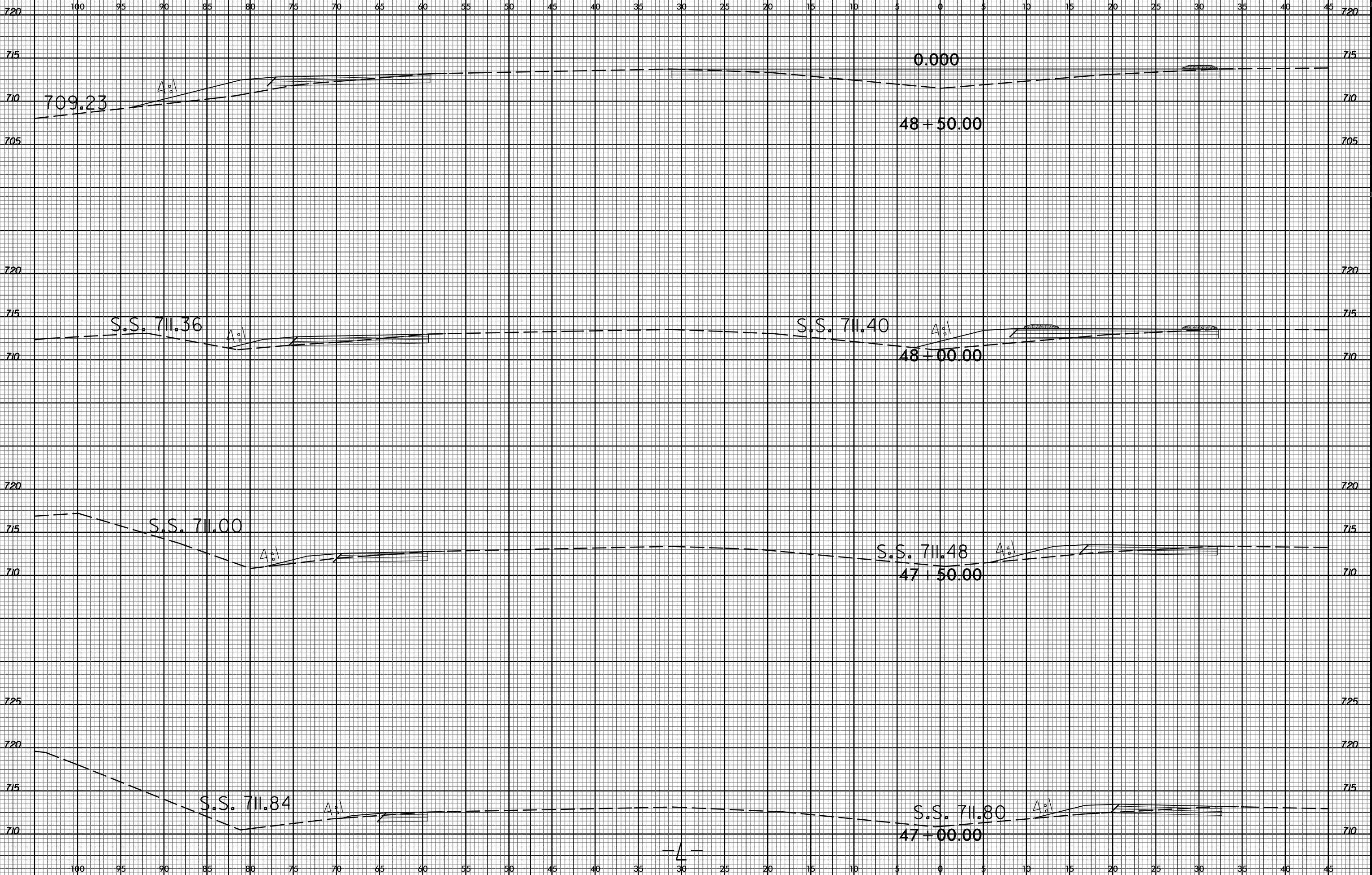



70 65 60 55 50 45 40 35 30 25 20 15 10 5 0 5 10 15 20 25 30 35 40 45 50 55 60 65 70 75

720 720

715 715

710 710

705 705

50 + 00.00

720 720

715 715

710 710

705 705

49 + 50.00

720 720

715 715

710 710

0.001

49 + 00.00

— / —

70 65 60 55 50 45 40 35 30 25 20 15 10 5 0 5 10 15 20 25 30 35 40 45 50 55 60 65 70 75



115 110 105 100 95 90 85 80 75 70 65 60 55 50 45 40 35 30 25 20 15 10 5 0 5 10 15 20 25 30 35

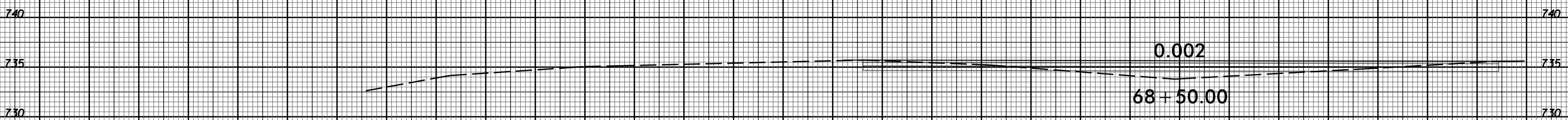
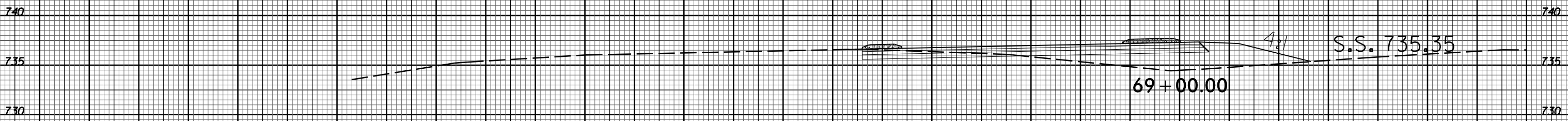
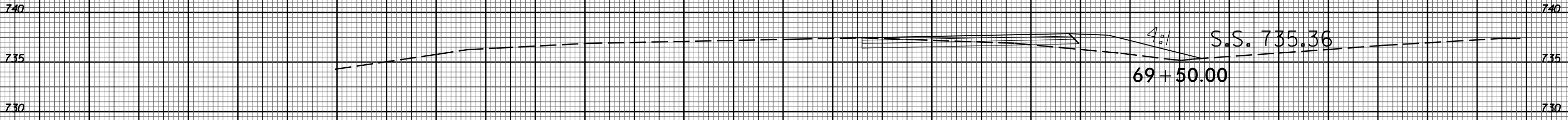
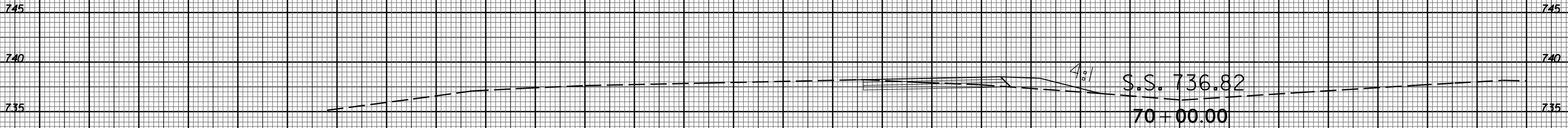

115 110 105 100 95 90 85 80 75 70 65 60 55 50 45 40 35 30 25 20 15 10 5 0 5 10 15 20 25 30 35

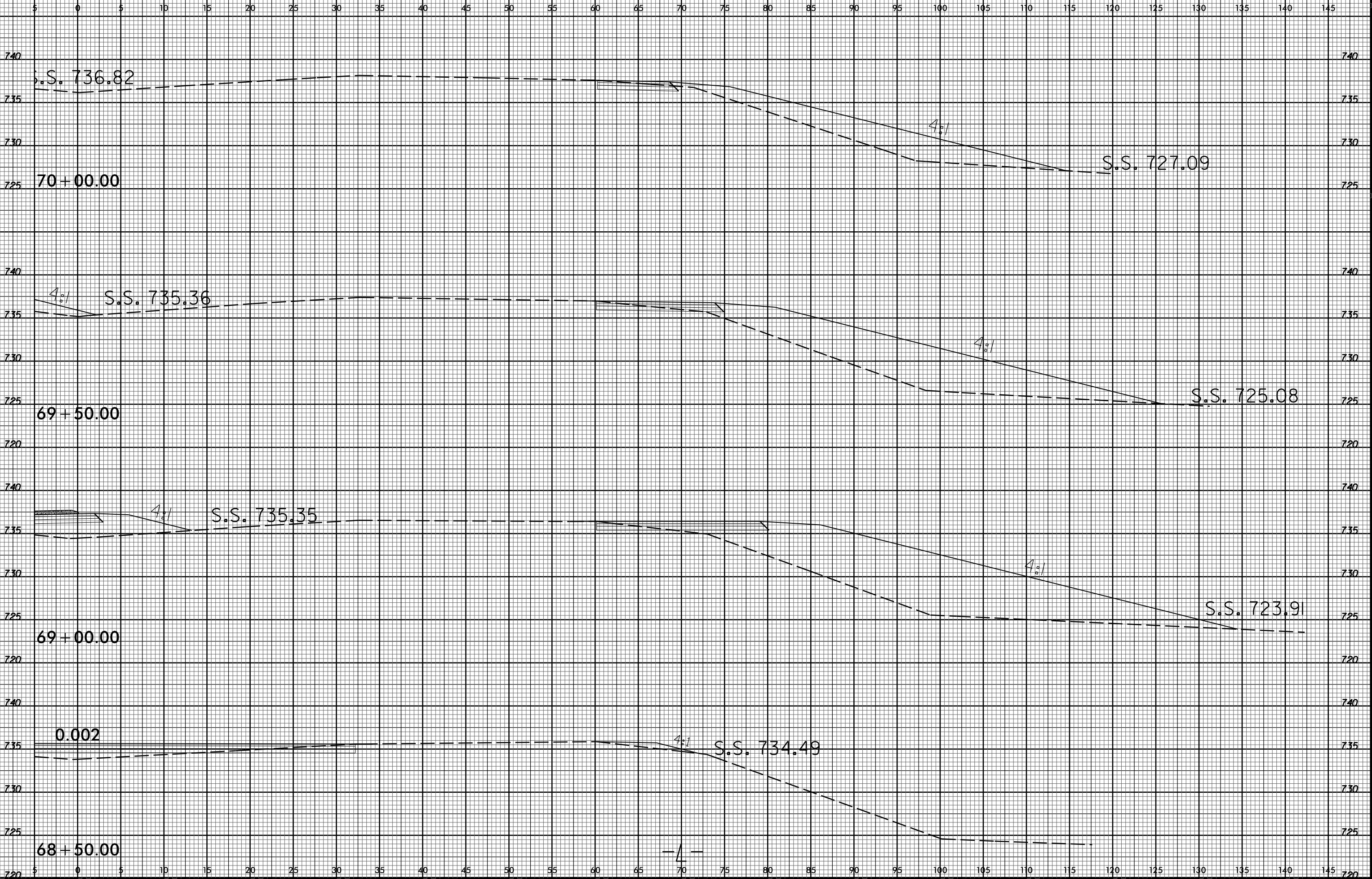

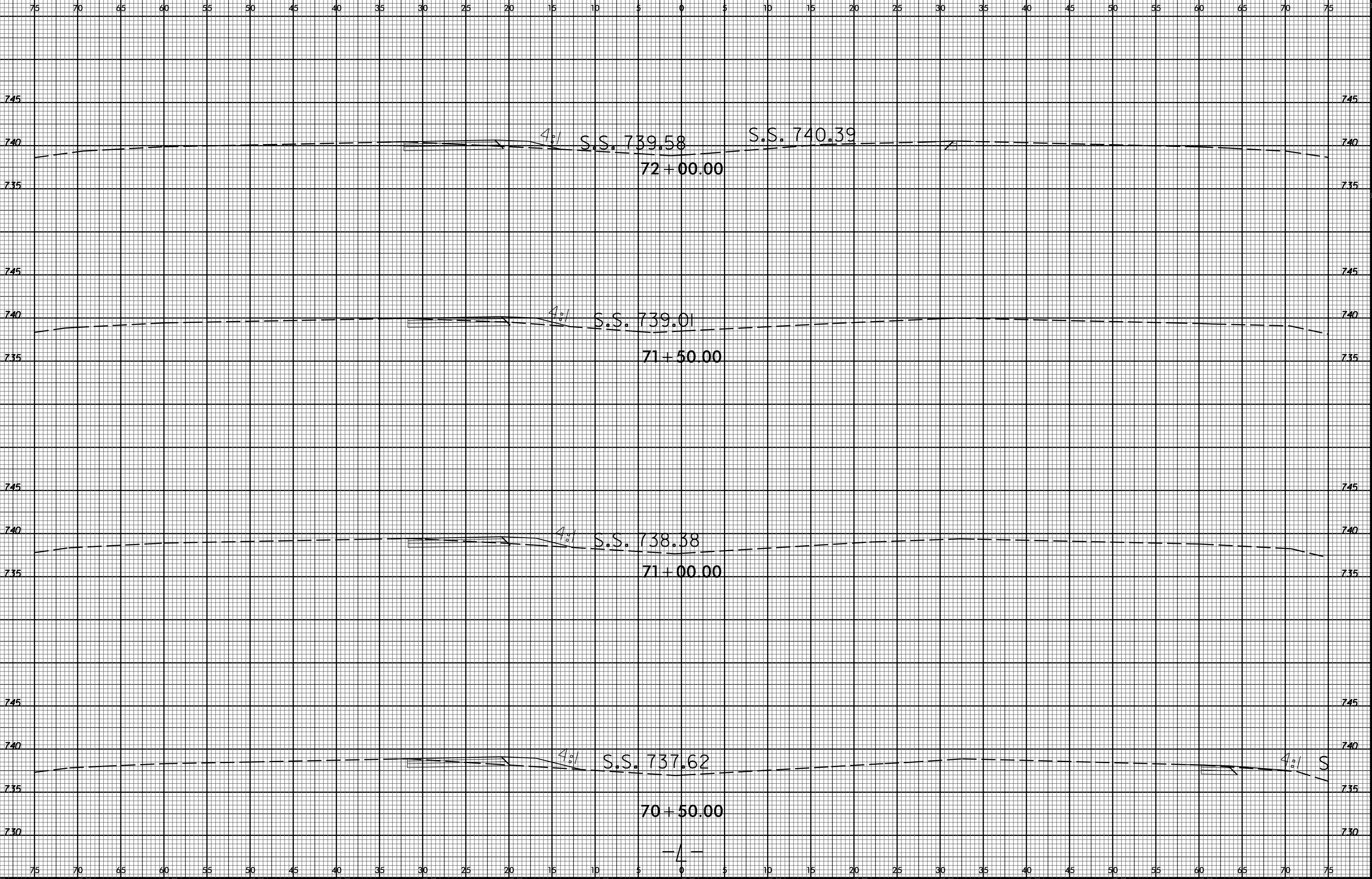



75 70 65 60 55 50 45 40 35 30 25 20 15 10 5 0 5 10 15 20 25 30 35 40 45 50 55 60 65 70 75

745 745

740 740

735 735

745 745

740 740

735 735

745 745

740 740

735 735

745 745

740 740

735 735

75 70 65 60 55 50 45 40 35 30 25 20 15 10 5 0 5 10 15 20 25 30 35 40 45 50 55 60 65 70 75

74+00.00

S.S. 741.37 A:1

73+50.00

4:1 S.S. 741.02

S.S. 741.16 A:1

73+00.00

4:1 S.S. 740.66

S.S. 740.94 A:1

72+50.00

4:1 S.S. 740.31

S.S. 740.76

24-MAY-2022 09:56
S:\DDC\BOK\Mech\Lenburg\W-5710AK_NC 16.01d Plank_Pleasant Grove_Superstreet_L.xpl.dgn
\$\$\$\$\$USERNAME\$\$\$\$\$



75 70 65 60 55 50 45 40 35 30 25 20 15 10 5 0 5 10 15 20 25 30 35 40 45 50 55 60 65 70 75

745 745

740 740

735 735

745 745

740 740

735 735

745 745

740 740

735 735

750 750

745 745

740 740

735 735

730 730

725 725

720 720

75 70 65 60 55 50 45 40 35 30 25 20 15 10 5 0 5 10 15 20 25 30 35 40 45 50 55 60 65 70 75

S.S. 741.16 A:1

76+00.00

S.S. 741.54 A:1

75+50.00

S.S. 741.62 A:1

75+00.00

S.S. 741.54 A:1

74+50.00

— / —

24-MAY-2022 09:57
S:\DDC\BOK\Mecklenburg\W-5710AK_NC 16.01d Plank_Pleasant Grove_Superstreet_L.xpl.dgn
\$\$\$\$\$USERNAME\$\$\$\$\$

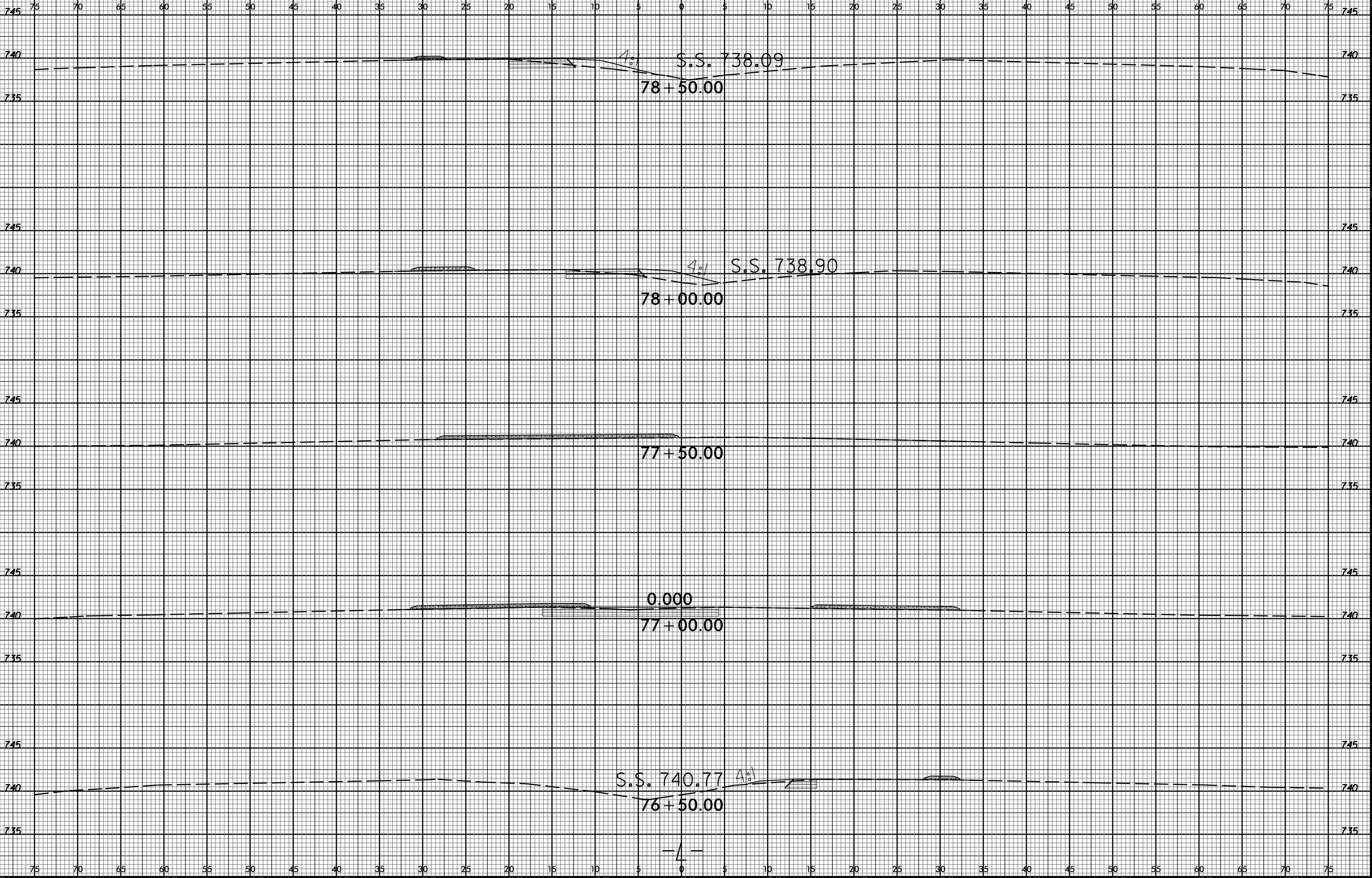



75 70 65 60 55 50 45 40 35 30 25 20 15 10 5 0 5 10 15 20 25 30 35 40 45 50 55 60 65 70 75

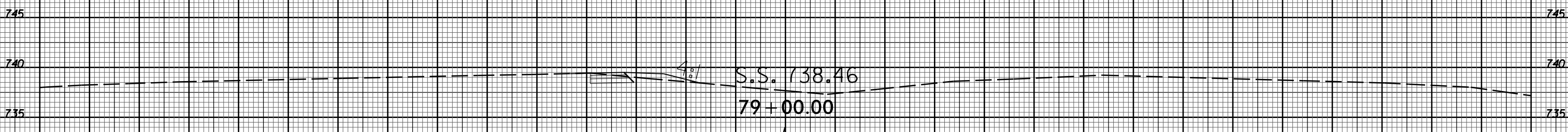
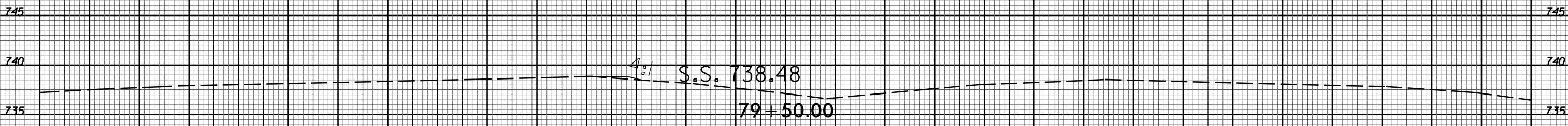
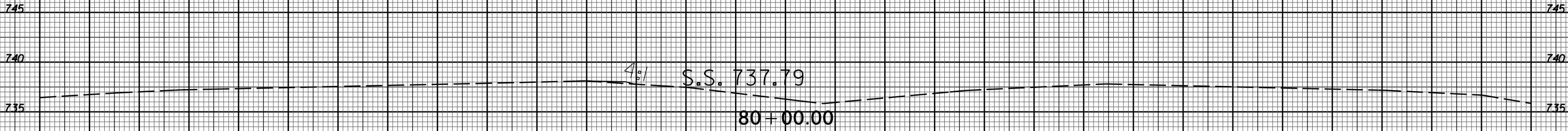
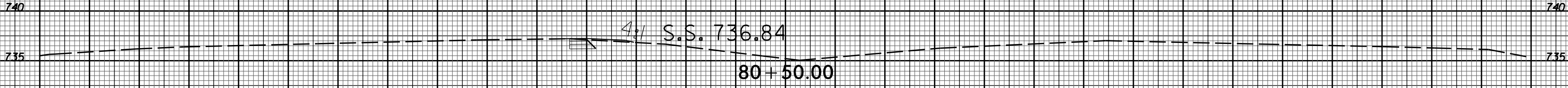

75 70 65 60 55 50 45 40 35 30 25 20 15 10 5 0 5 10 15 20 25 30 35 40 45 50 55 60 65 70 75

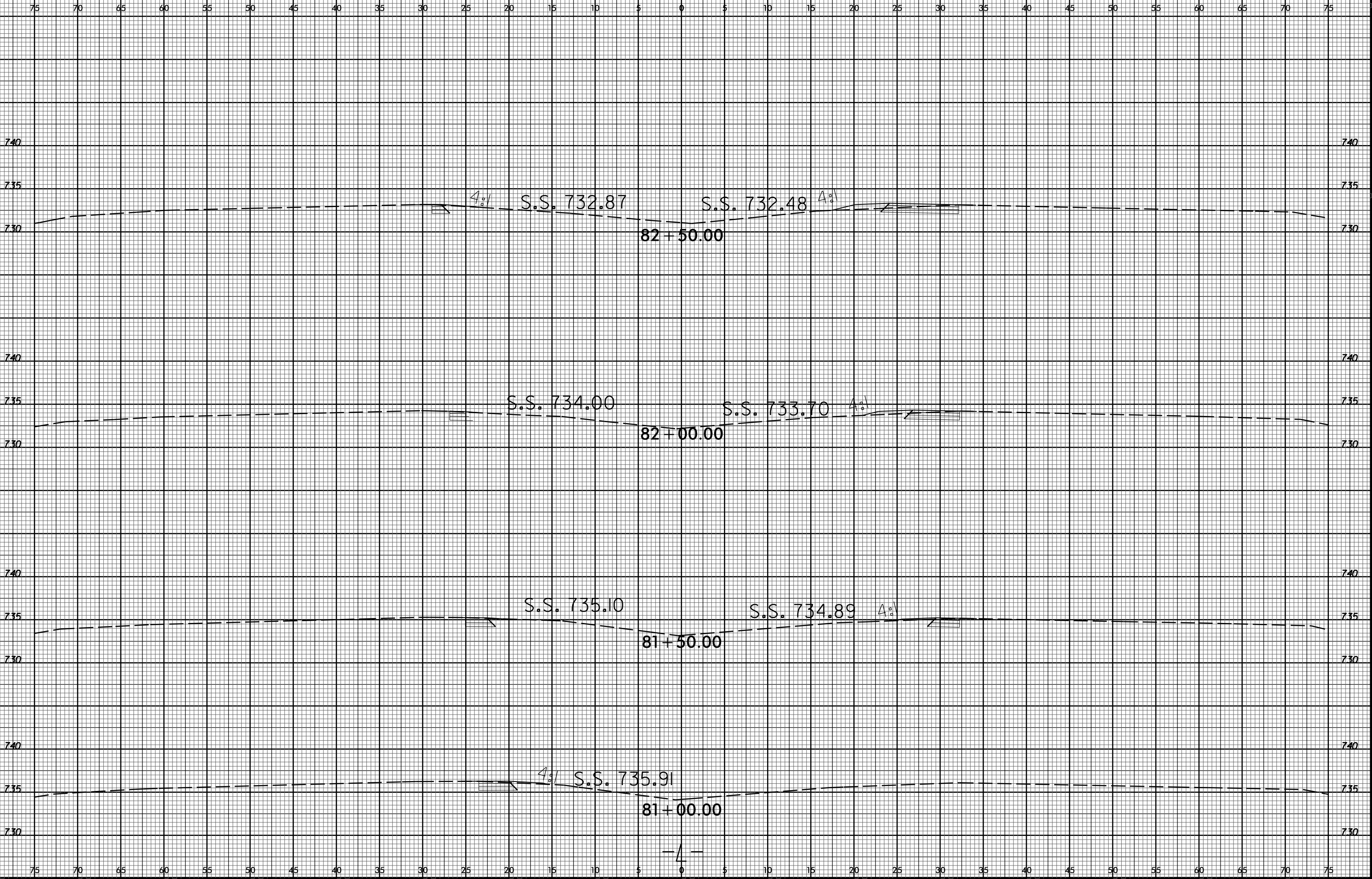

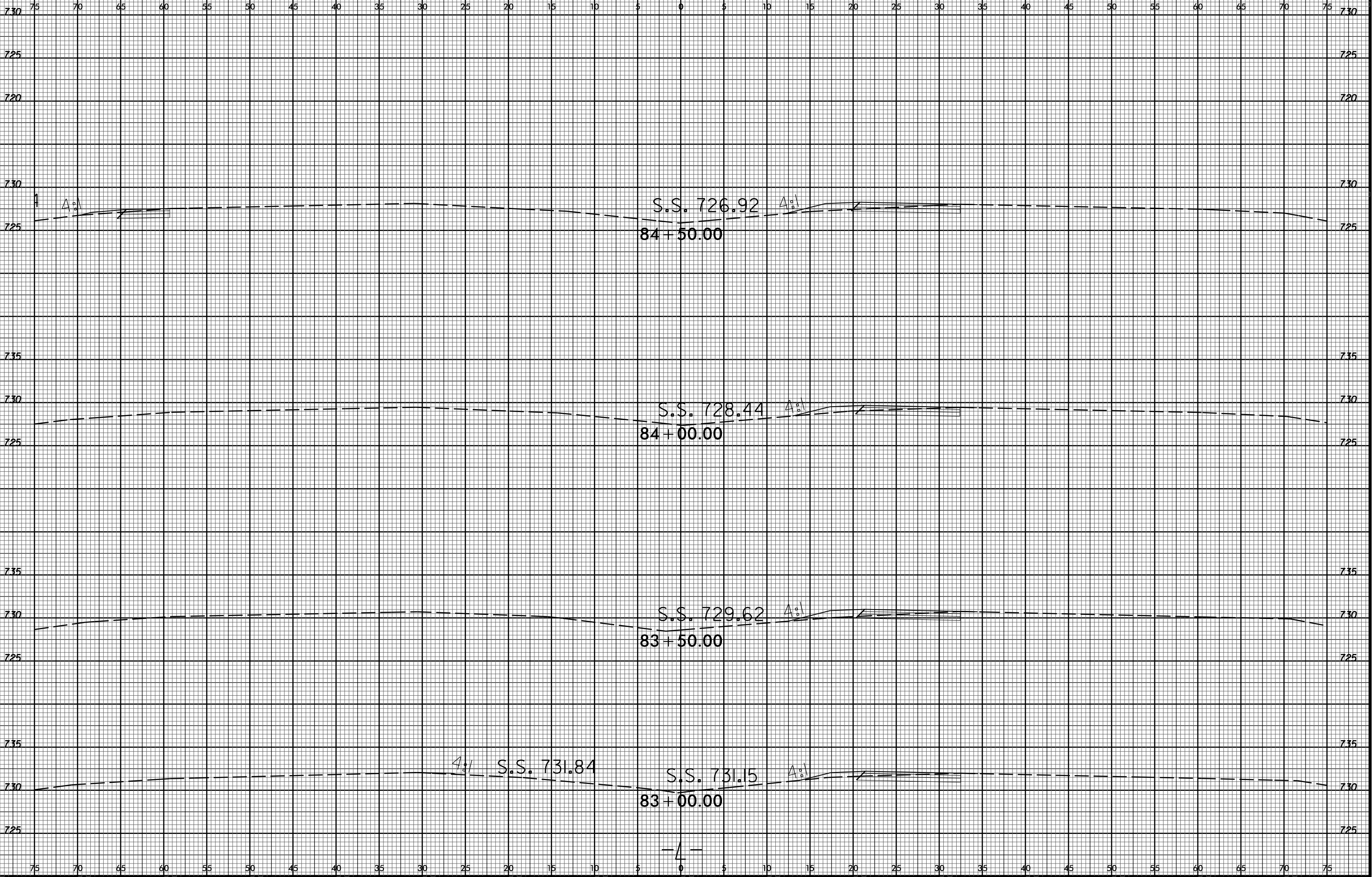

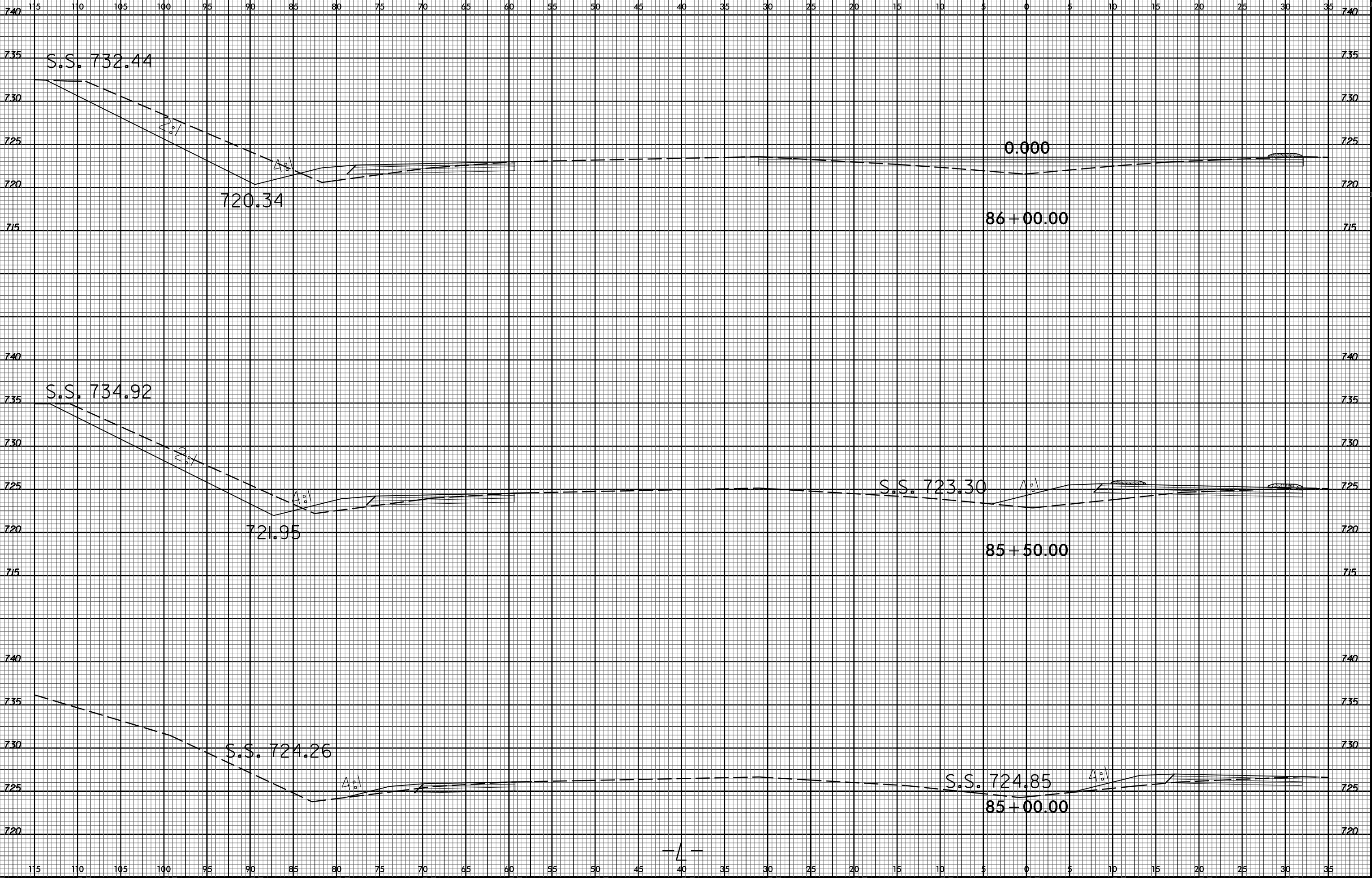

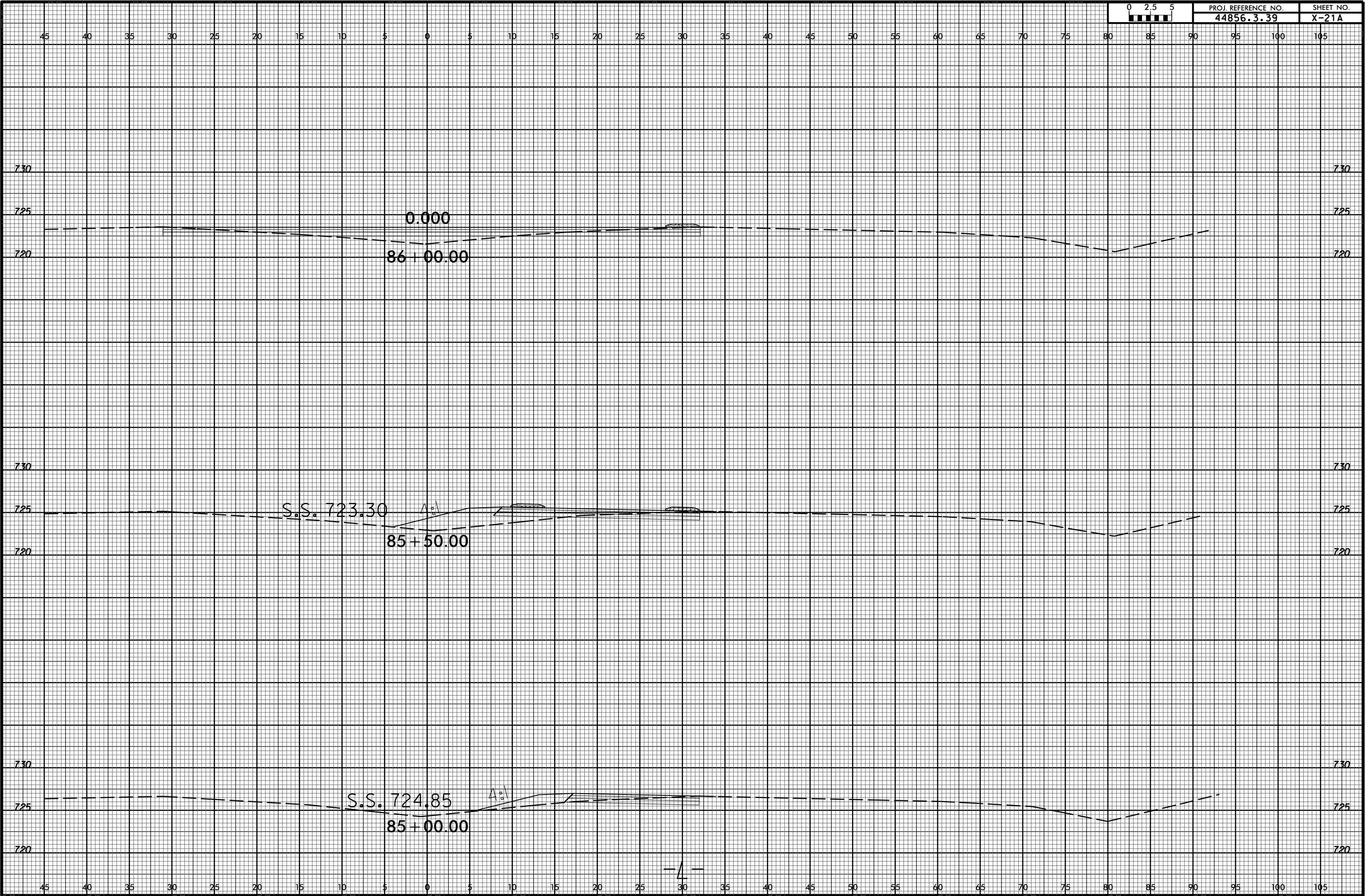



75 70 65 60 55 50 45 40 35 30 25 20 15 10 5 0 5 10 15 20 25 30 35 40 45 50 55 60 65 70 75

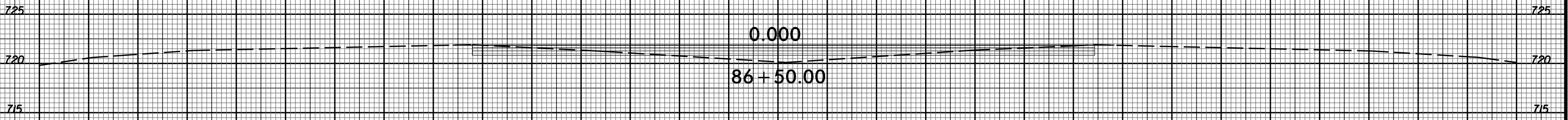
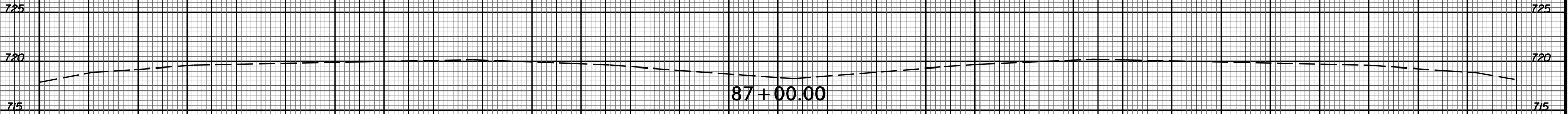
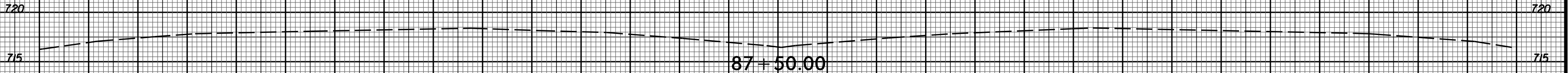



75 70 65 60 55 50 45 40 35 30 25 20 15 10 5 0 5 10 15 20 25 30 35 40 45 50 55 60 65 70 75

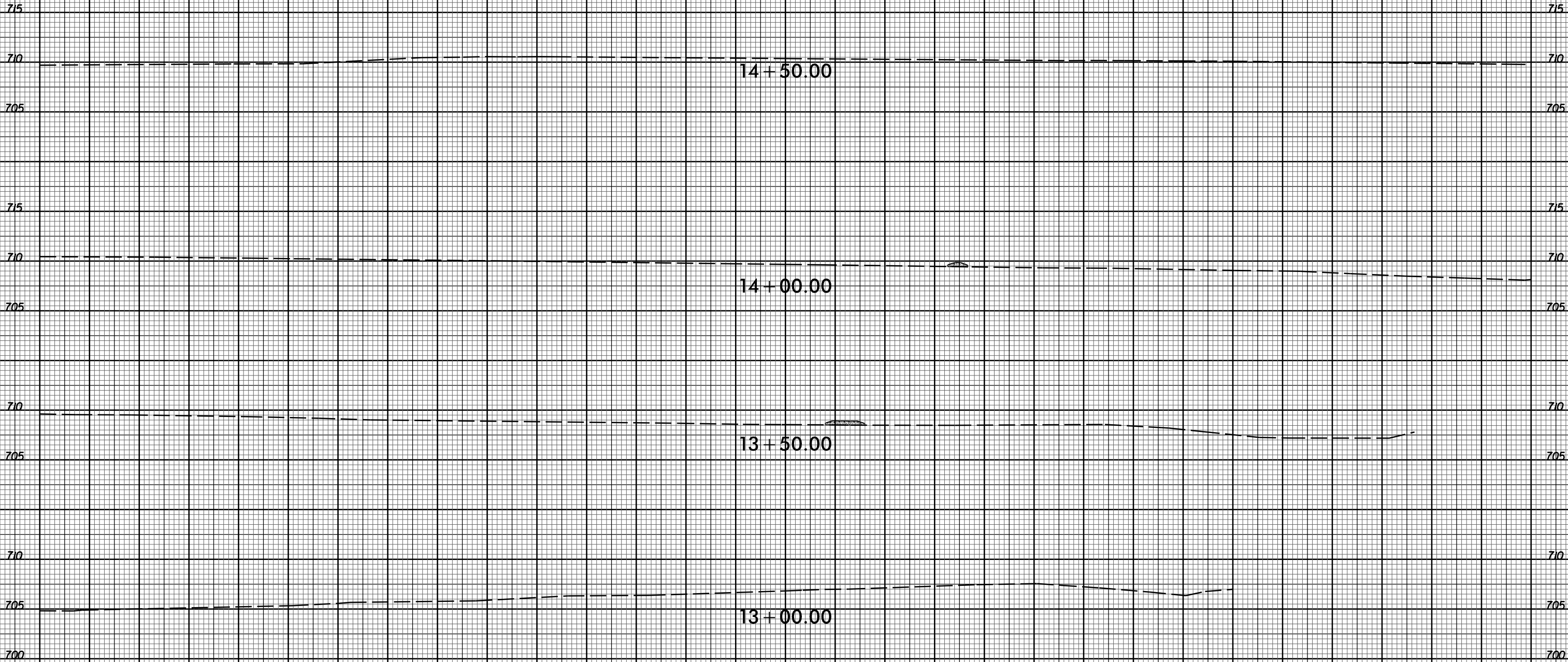

-Y-

